

2017

english version 02/2017

LSL MOTORRADTECHNIK GMBH

D-47809 Krefeld-Oppum
info@LSL.eu



Making good bikes perfect

02/2017 english version
Climate-neutral print





THE SPIRIT OF MERIDEN

The legendary British engineering - until the late 1960s, even the insignificant Meriden contributed significantly to its international radiance. This is where the motorbikes were created at the Triumph headquarters, where Hollywood idols such as Marlon Brando and Steve McQueen also ventured off the screen. And thanks to their classic design, they are still regarded as styliques.

Naked. The chassis light and handy. The engine as a central, powerful sight. And this unmistakable sonorous sound: we have now reinterpreted the original British success story and consistently implemented it with our

"The Spirit of Meriden". For the road. For the eye. For her! Let our tribute to the Roaring Sixties have a relaxed moment. And take some time for our new catalog of products that have emerged in this spirit. Because with what could the approaching season be better than with a few new ideas ...

Sincerely yours



_ LSL MOTORRADTECHNIK

About LSL	4
Extreme test in racing	6
Build your Bike	8
Clubman® motorcycles	10
Clubman® Spirit of Meriden	12



_ CHASSIS GEOMETRY

Chassis Geometry	14
Top Yoke Kits	16



_ HANDLEBARS

28.6 mm X-Bar Handlebars	20
28.6 mm Clamps	23
22.2 mm Handlebars	26
22.2 mm Clamps	32
25.4 mm Inch Handlebars	34
25.4 mm Inch Clamps	39

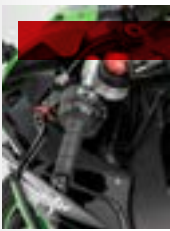

_ CLIP-ON

Sport Match	41
Tour Match	44



_ HANDLEBAR ACCESSORIES

Grips	49
Bar end weights	50
Lever Guards	52
Mirrors	53
Mirror bracket kits	56

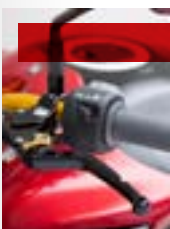

_ BRAKE SYSTEM

Brake and Clutch Lever	58
Scooter-Lever	67
Brake Fluid Reservoir	68
Stainless steel Brake Lines	70

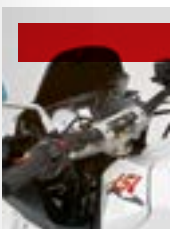

_ SUPERBIKEKITS

Superbike Handlebarkits	73
Accessories	77

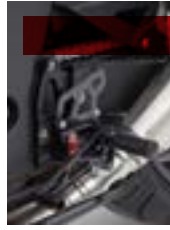

_ REAR SETS

2Slide Rear Sets	79
Rear Sets	82
Gear Shifter/Foot Brake	87
Foot Pegs	88
Adjustable linkings	89



_ STEERING DAMPERS

Steering Dampers	97
Shinin Clamps	99

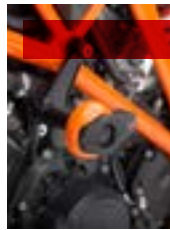

_ PROTECTORS

Crash Pads®	101
Achs Balls	107
Lifter	109

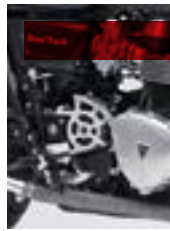

_ BODYWORK

GFK- / aluminum-fender	111
Seats/Clubman® Bags	114
Oil Filler Cap	115
Bodywork Cover	116
Number Plate Holders	118

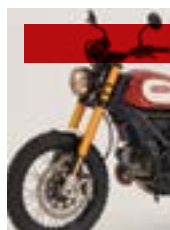

_ LIGHTING

Headlight	121
Headlight Brackets	122
Urban Headlight Kit	124
Indicators / Rear Lights	126

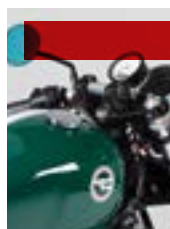

_ INSTRUMENTS

Motogadget Instruments	128
Velona Instruments	129
Instrumenthousing	129

Sales Information/ Conditions	130
Index/Imprint	131



Last year we extended the production area of the company to the extension of a hall.

PASSION FOR A THEME

LSL - behind this brand name is a team of hard-working specialists who dedicate themselves to the design of high-quality products with the utmost energy and passion.

LSL accessories are designed and drawn in Krefeld. Jochen Schmitz-Linkweiler, founder and head of the company, stands for the ideas of the products and is responsible for their concrete implementation until the start of production. Highly specialized production companies throughout Germany then produce the individual components from machined materials before they are meticulously measured, assembled and packaged on site.

As a European company, we are aware of the importance of technological innovation for the further development of our products. With a highly qualified development department and in cooperation with universities and testing organizations (in particular TÜV Rheinland), we create the founda-



Founder / Technical director: Jochen Schmitz-Linkweiler

tions for directional products, define our own standards that go far beyond legal requirements.

A certificate to this pre-eminence is the success that the Federal Ministry of Transport has raised an LSL-own test profile 2011 to the directive for the examination of special steering. For the aluminum linkage and adjustable levers LSL carries the seal of approval TÜV.com.

But we also listen to your experience very carefully when you criticize our products. Because you and your satisfaction are the top criteria for the meaning and function of our accessories and your feedback is often based on experiences that can provide valuable information for a targeted further development.

The complexity of the technology requires a high level of education - in our company and in sales. That is why we consciously rely on professional knowledge and further education! Without exaggeration, we can say that every LSL employee knows his product from the effective and is always able to help you competently. Visit one of our support partners and you are sure to find a company that can advise you in all details.

Growth belongs to the development of a company. LSL is growing slowly, product by product. We still take the time that is necessary to realize perfection down to the last detail. And we can afford this "luxury" at any time! This is because LSL is a privately-owned company - and thus completely independent of the short-term yield expectations of profitable investors.

Beyond pure technology, we are always dealing with people. Joy of work is based on the appreciation of the other, but also on the fair dealing with each other. Afterwards, the entire LSL team acts: in their own ranks and towards their customers.

We are glad that we can live these principles in the small niche of motorcycle technology and thank you for allowing us to do this by choosing and using our products.

YOUR **CONTACT PERSON**

Competence, consistency and creative power – the LSL sales team provides competence for 2017.



SALES/CUSTOMER SERVICE: **VERA NEUMANN**,
responsible for customer service



SALES/LSL WEBSITE: **NICOLE HEIMER**,
Customer Service and Media



SALES EXPORT: **GÉRARD VAN TREECK**,
Brandnew enhancement for the Export-Department



SALES/RACING: **ARNE FISCHER**,
veteran from our production, now specifically for technical details and racing support



SALES MANAGER: **KAI FRIEDRICHSEN**,
the man knows the industry and the products, leads the team and yet is always in the middle



BRAND MANAGEMENT/DESIGN: **NORA HELMS**,
brings LSL in shape – from display to packaging

_ EXTREME TEST IN RACING

"Always when fork and shocks are compressed at their limit, I don't want to know how many weight is resting on my LSL rear sets!"

Horst Saiger

Horst Saiger
december 2016

EXTREME TEST IN RACING

Experiences from racing have played an important role in the development of LSL products. Not for nothing, LSL has been supporting teams in the World Endurance Championship and road racing in Ireland and the Isle of Man for years.

Long-distance sport teaches us how parts have to be made. How stable do the components have to be so that they do not fail completely after a fall? What must a riser base plate be able to with-

stand when the motorcycle bounces after a jump to a maximum of one until the panel touches the ground? Here the driver has to be able to rely completely on our parts.

Our long-distance racing also has a decisive influence on our ergonomic products. Where should the foot rests sit so that the knees do not ache. How the mute bucket has to be inclined when a driver has to support himself over every hour, every time he brakes.

Experiences from the racing industry are used on the road products one by one.

In addition to the professional sport, the sport is very important in the current brand cups. Also in 2017 LSL supports the Triumph Street Triple Cup, Suzuki SV 650 Cup and GSX-R Cup.



FURTHER
TEAMS AND CUPS ...

... using LSL Handlebar, footrests, levers and other LSL equipment.

Team Bolliger (on Kawasaki)
www.bolligerteam.ch
Endurance World Championship

Kawasaki Schnock Team Motorex
www.motorrad-schnock.de
IDM Superbike and Superstock

Triumph Street Triple Cup
www.Triumph-Cup.de
Motorrad action team

Team HPC-Power Suzuki Racing
www.hpc-racing.de
IDM Superbike and Superstock

Schubert-Motors NRT 48 (on BMW)
www.nrt48.de
Endurance World Championship

Suzuki GSX-R Cup and SV 650 Cup
www.world-of-motorcycles.de
Cup at IDM

_ LSL **BUILD YOUR BIKE**

Mounting different LSL parts changes every motorcycle into an individual special bike.

Let us inspire you!

- _ 1 2SLIDE REARSET
- _ 2 FOOT PEGS
- _ 3 LIFTER



_ 1 2Slide Rearset from page 78



_ 2 Foot pegs from page 88 and Adjustable linkings on page 89



_ 3 Lifter on page 109



_ 4 Crash Pad®, screwed with adapter plate from page 100



_ 5 Achs Balls from page 107



_ 6 Brake Box from page 68



_ 7 Tour Match from page 44



_ 8 Lever Guards on page 52 and Brake / Clutch Lever from page 58



JOCHEN SCHMITZ-LINKWEILER
DIREKTOR LSL

„For our brand Clubman® we claim to develop a pure design and equip this with high quality components, to achieve besides inspiring visual appearance the riding dynamics of a current sport bike.“





LSL has been involved in the design of chassis components since foundation. We are developing own geometry concepts, testing... testing... testing... - and finally excellent chassis data is created.

In the in-house motorcycle manufacture, the LSL team converts selected basic motorcycles into passionate genuine clubman models. Embedded in coherent, classic shapes, traveling machines with excellent handling characteristics are created.



_ CLUBMAN® THE SPIRIT OF MERIDEN



Technical Data

Engine:	1200 ccm Twin (90 x 68 mm)
Chassis:	tubular steel-cradle
Geometry:	65.5° steering angle, trail 98 mm (fork width 210 mm / Offset 30 mm)
Wheel sizes:	wire-spoke rims 3.50 x 17 front; 5.50 x 17 rear
Tyre sizes:	120 / 70 - 17 front; 170 / 60 - 17 rear
Wheel base:	1415 mm
Seat height:	820 mm



Clubman® „The Spirit of Meriden“ – a homage on the birth of British motorcycle industry. A motorcycle packed with the finest ingredients of technical equipment.

The black Öhlins fork complemented with the ultralight KINEO wheels plays with bumping on poor road surface. The upright seating position with LSL Superbike handlebar defines riding competition new. Everything fits in perfectly. Details are adjustable on any individual rider.

The Concept – the spirit – of this new Clubman combines the classic attitude of a Modern Classic perfectly with today's possibilities of motorcycle engineering.



Block: The handcrafted detachable single seat, carrying the unique design of Jens vom Brauck, can be exchanged easily with standard double seat.



_ CHASSIS GEOMETRY

„If I sit on a Clubman, then I know exactly that everything is perfect - the seating position was made by Jochen“

U. Brée

*Uli Brée, screenwriter and
enthusiastic motorcyclist*

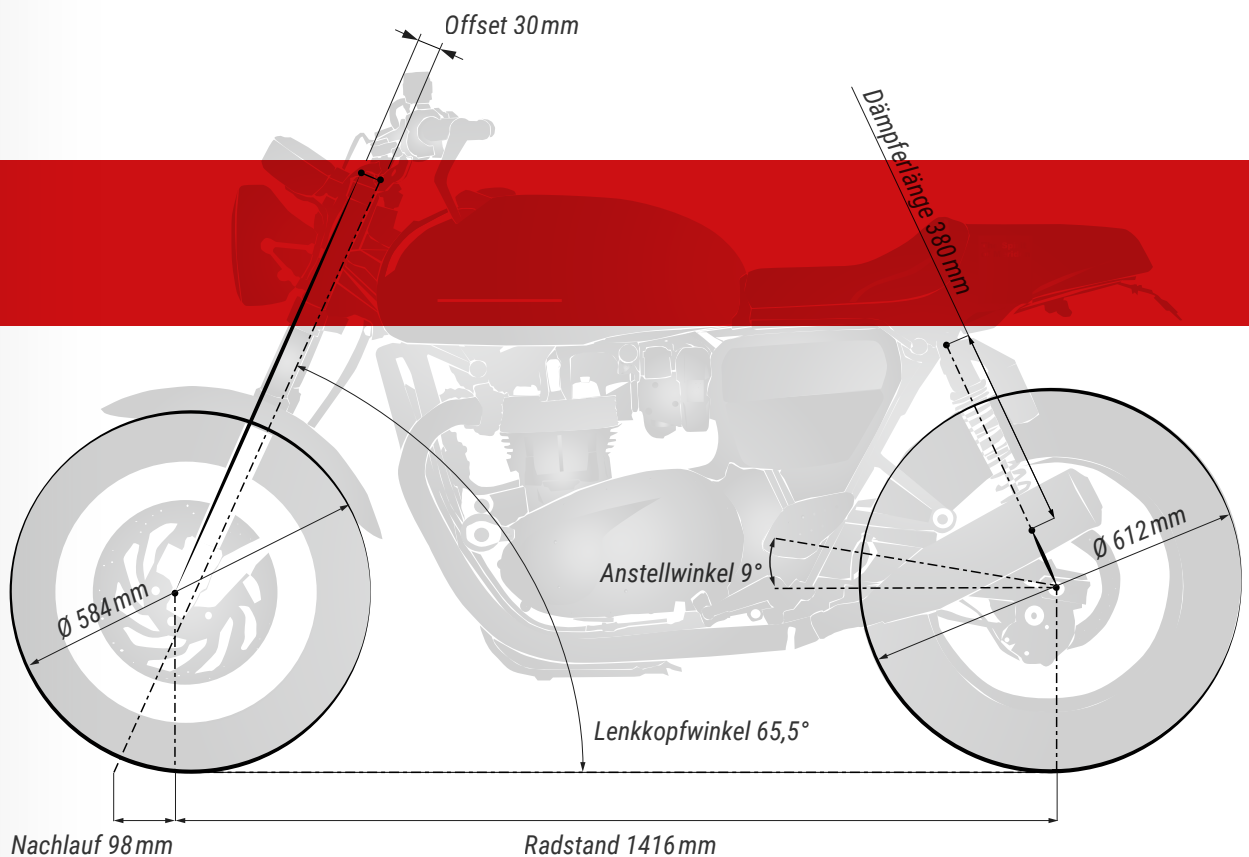

GEOMETRICALLY ADJUSTED

Since the founding of LSL, the company has been working on the design of chassis components. Whether the first high-heeler Enduro conversions or the first Clubman based on the Harley Sportster, there was always a careful consideration of the existing geometrical data and an adaptation of all individual components to the desired geometry design right from the beginning of development.

Today, we are able to do this much faster and more precisely. The geometry measuring system, which was originally developed for measuring the ergonomic points of a motorcycle, is now also excellent for the detection of steering head angle, caster and swing position.

The chassis values are significantly influenced by the length of fork and spring struts and with respect to the follow-up of the offset (stem) of the top yoke. We do not want to burden you with details of this interplay, just so much that LSL has developed its own top yoke kits, which give you more modern, sporty suspension data, even for vehicles that are more tranquil.

The top yokes are milled from the full aluminum, stiffer and lighter than the series and offer a more precise driving behavior and better high speed stability with an adapted offset (distance between the standpipe and the fork pivot).

With the steering head angle, which is additionally influenced by the length of the rear wheel suspension, the upgraded models gain real sports qualities.

The upper top yoke is designed for use with mute cones without clamping blocks. However, a conventional pipe guide (each cross-section) can also be installed by boring existing countersinks and using the clamping blocks provided for this purpose. The handlebar clamps must be ordered additionally.

LSL offers ready-made top yoke kits for a conventional Öhlins fork FG 433 and the FG 324/424 upside-down fork.

In addition to the top yokes these kits also include a brake disc distance ring (as far as this is required). There are also suitable wheel mounting kits (for original or KINEO wheels as well as brake caliper adapters and complete fender solutions).

TOP YOKES KITS FOR SERIES FORKS

The top yoke kits are supplied completely with all parts for the bolting of the front wheel, possibly necessary brake disk distances and guard brackets for the original fender plate.

The kits do not contain a new steering head tube. Here the original bearing tube is still used. A changing, pressing of

the steering head pipe is carried out free of charge as a service from LSL.

Replacement of the lamp holders is usually required. Please order the suitable holders from the LSL accessory program (page 120).

The mounting of these parts is demanding and should be done only by a trained mechanic.



TOP YOKES KITS **FOR THE ORIGINAL FORK**

model	year		width/offset	item no	EUR
Kawasaki W-Models					
W 650	-00	EJ650A	205/42	140K086SW	619,00
W 650	00-06	EJ650A	205/42	140K125SW	579,00
W 800	all	EJ800A	205/42	140K137SW	579,00
Triumph Twins					
Bonneville/Thruxton/Scrambler w/ speedo cable	-09	908MD/ME	200/52	140T031SW	599,00
Bonneville/Thruxton/Scrambler w/ electric speedo	10-15	908MD/ME	200/52	140T050SW	599,00
<i>The top yoke sets are delivered without handlebar clamps, please order if necessary!</i>					
handlebar clamps					
handlebar clamp kit standard		black	22.2 mm	140+KL22SW	79,95
handlebar clamp kit 1 inch-handlebar		black	25.4 mm	140+KL25SW	79,95
handlebar clamp kit X-Bar-handlebar		black	28.6 mm	140+KL28SW	79,95
<i>You can find the lamp holders in suitable designs for the various vehicle models under LSL lamp holders from page 120.</i>					

model	colour	item no	EUR
bracket kit rectifier / horn			
Triumph Twins	black	728TR50	49,95
ignition relocation kit			
Bonneville Scrambler Thruxton	silver	728T024RSI	32,95
Bonneville Scrambler Thruxton	black	728T024RSW	32,95



TOP YOKES KITS FOR STRONG FORKS

The mounting of these parts is demanding and should be done only by a trained mechanic.

For some selected models, LSL has developed complete assembly solutions for high quality Öhlins forks. The forks differ in the standpipe diameter and also in the length compared to the series forks. The following tables contain all the

components necessary for the conversion of your vehicle. For the interplay of a balanced chassis geometry, we also recommend the length of the struts to be used.

FORK KITS FOR THE RWU-GABEL FG 433

model	year		width/offset	item no	EUR
Triumph Bonneville / Thruxton					
Bonneville/Thruxton	11-15	908MD/ME	200/52	140T05043SW	899,00
Öhlins-fork FG 433		43 mm	800 mm	140FOHFG433	2189,00
brake calliper adapter		40 mm	for 320 mm	2410HKKL32	99,00
Brembo-brake caliper, left		40 mm	titan	240BG4LT1	359,00
fender with matching bracket for		17"-front wheel		5060HRWU17	159,95
<i>Necessary shock length when using 17"-front wheel: 375 mm ;</i>					
<i>Headlight bracket 43 mm see LSL-Programme; Mounting on models < 2010 only by changing to electronical tachometre possible.</i>					
Triumph Thruxton 1200					
Thruxton 1200	16-	908MD/ME	210/30	140T07243SW	998,00
Öhlins-fork FG 433		43 mm	800 mm	140FOHFG433	2189,00
brake calliper adapter , pair		40 mm	for 310 mm	2410HKKD31	198,00
Brembo-brake caliper, pair		40 mm	titan	240BG4T1	718,00
fender with matching bracket for		17"-front wheel		5060HRWU17	159,95
wheel axle kit for		Original-front wheel		141STT72	69,95
wheel axle kit for		KINEO-front wheel		141SKT72-2	159,95
<i>Necessary shock length when using 17"-front wheel: 385 mm ;</i>					
<i>Headlight bracket Ø 43 mm see LSL-Programme lighting up to page 120.</i>					

FORK KITS FOR THE USD-FORK FG 324

Triumph Scrambler					
Thruxton 1200	11-15	908MD/ME	205/48	140T0510HSW	999,00
Öhlins-fork FG 324		50/54 mm	800 mm	140FOHFG324	2350,00
brake calliper adapter		100 mm	for 310 mm	2410HURL31	389,00
Brembo-brake caliper, pair		100 mm	silver	240BRG4L	399,00
fender with matching bracket for		19"-front wheel		5060HFEX	298,00
<i>Necessary shock length when using 19"-front wheel: 375 mm ;</i>					
<i>Headlight bracket Ø50/54 mm see LSL-Programme lighting up to page 120; Mounting on models < 2010 only by changing to electronical tachometre possible.</i>					
Ducati Scrambler					
Ducati Scrambler	Icon/Classic		210/50	140D0470HSW	899,00
Öhlins-fork FG 324		50/54 mm	800 mm	140FOHFG324	2389,00
brake calliper adapter		100 mm	for 330 mm	2410HURL33	389,00
Brembo-brake caliper, left		100 mm	silver	original brake caliper	-
fender with matching bracket for		19"-front wheel		5060HFEX	298,00
<i>Necessary shock length when using 19"-front wheel: original length ;</i>					
<i>Headlight bracket Ø50/54 mm see LSL-Programme lighting up to page 120.</i>					

With conversion of the top yoke kit, the exchange of the lamp holder is necessary. LSL offers a wide range (please see page 120). The matching handlebar clamps for the desired type of handlebar must be ordered separately.



_ HANDLEBARS





LSL HANDLEBARS PRESSURE AND PRODUCTION

Hard braking can bend the handlebar - this experience was made by LSL technicians in the early 1990s. steel handlebars mounted with our Superbike handlebar kit on fast sports tourer, bent forwards when braking.

Extensive investigations brought to light that specified test loads for handlebars by the Federal Motor Vehicle Office (the directive came from the year 1978) were significantly underestimated and that handlebars for modern Superbikes simply need to be able to do more.

Test runs with today's adventurous sounding test setups showed that each handlebar side has to endure over 40 kg load at an average heavily braking. In today's possible delay of a g again still higher forces should be found.

LSL consequently responded to this new requirement and asked to develop a brand new individual test profile in cooperation with TÜV in Cologne. It consists of a higher static load that must withstand without deformation of the handlebar and an individually created testing method for the duration test run, which the LSL handlebar must endure.

LSL PERFORMANCE

Performance Handlebars



TÜV.com is a label which is awarded by TÜV Rheinland for outstanding product features that go far beyond the minimum standards required by law.

This label was awarded for the aluminum Superbike handlebar. Details can be found on the website www.tuv.com/de.



The LSL internal endurance profile is a benchmark for a realistic handlebar test.

DRILLING TEMPLATE - THE PROFESSIONAL TOOL SET

In order to ensure the firm seating of the switch assy, the holes for the original handlebar twist pins must be transferred to the new handlebar. With the LSL drill template you can easily transfer the distance dimension of the hole and while drilling it is fed through the bushing. (on page 47)



_ HANDLEBARS 28.6 mm X-BAR

28.6 mm X-BAR - **TAPERED HANDLEBAR**

- _ Strong handlebar with 28.6 mm clamping diameter, higher bending resistance, lower resilience
- _ Conified inside and outside, 22.2 mm diameter in the grip area
- _ Thickness 4.5 mm in the clamping area and 4 mm at the end of the steering tube
- _ Material AlCuSiMn in quality T6
- _ surface depending on the colour either high gloss polished or pearl blasted
- _ colour anodised in up to 7 different colour variations



The material of the LSL X-Bar-handlebar has been chosen in a way that even in case of most extreme damage the steering tube does not break but bends.

LSL PERFORMANCE

Performance X-Bar

- _ All X-Bar-handlebars tested by requirement of German TÜV-standard
- _ Regular COP-tests confirm constant quality
- _ Fitting ability to certain motorcycle models is tested at LSL workshop for a big range of models

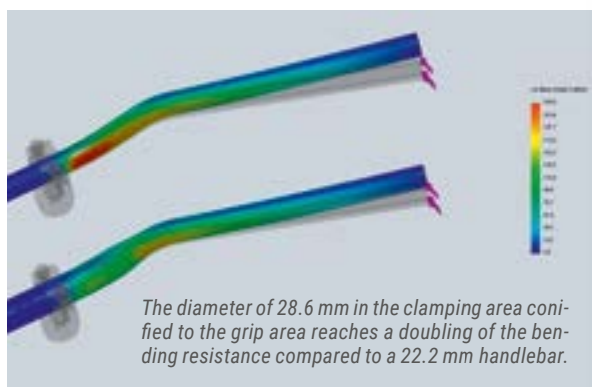

The diameter of 28.6 mm in the clamping area conified to the grip area reaches a doubling of the bending resistance compared to a 22.2 mm handlebar.

COLOUR

X-Bar handlebars colour	surface	order info
black	pearl blasted	item no + SW
silver	pearl blasted	item no + SI
anthracite	pearl blasted	item no + AN
gold	polished	item no + GO
blue	polished	item no + BL
white	coated	item no + WT
carubon	matt	item no + CM

EXTRA STRONG

The Superbike Handlebar X 01 is also available in two surface variants. As a carbon-coated handlebar, a carbon hose sleeve adds to the stability of the bar.

With the white-coated handlebar, the two LSL logos on the handlebar give a strong color accent.



_ XD1 DRAG BAR

Sporty narrow with 20° cranking

black	pearl blasted	128AXD1SW	89,95
silver	pearl blasted	128AXD1SI	89,95

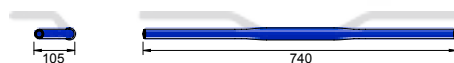

The LSL Superbike handlebar is shown in grey as reference.

_ XD2 DRAG BAR

Dragster handlebar for heavy custom bikes.

black	pearl blasted	128AXD2SW	89,95
silver	pearl blasted	128AXD2SI	89,95



The LSL Superbike handlebar is shown in grey as reference.

_ X00 CROSS BAR

Will be the choice for the streetfighter and motocross rider.

black	pearl blasted	128AX00SW	89,95
silver	pearl blasted	128AX00SI	89,95
anthracite	pearl blasted	128AX00AN	89,95
gold	polished	128AX00GO	89,95
blue	polished	128AX00BL	89,95
carbon covered	matt	128CX00CM	139,95

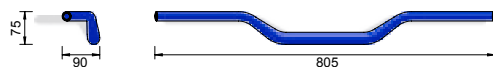

The LSL Superbike handlebar is shown in grey as reference.

Also Carbon covered available !



_ XB3 TOUR BAR

The comfortable strong bar for tourers.

black	pearl blasted	128AXB3SW	89,95
silver	pearl blasted	128AXB3SI	89,95

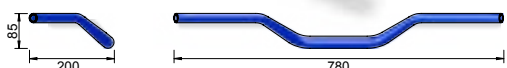

The LSL Superbike handlebar is shown in grey as reference.

_ HANDLEBARS 28.6 mm X-BAR

Conversion from 22.2mm handlebar to 28.6 mm X-Bar s. page 23



_ XN1 SUPERBIKE FLAT

The classic Superbike shape but a little lower.

black	pearl blasted	128AXN1SW	89,95
silver	pearl blasted	128AXN1SI	89,95
anthracite	pearl blasted	128AXN1AN	89,95
gold	polished	128AXN1GO	89,95
blue	polished	128AXN1BL	89,95



The LSL Superbike handlebar is shown in grey as reference.

As well in white coated or carbon-wrapped!



_ X01 SUPERBIKE

The classic Superbike shape.

black	pearl blasted	128AX01SW	89,95
silver	pearl blasted	128AX01SI	89,95
anthracite	pearl blasted	128AX01AN	89,95
gold	polished	128AX01GO	89,95
blue	polished	128AX01BL	89,95
NEW white	coated	128AX01WT	99,95
carbonummantelt	matt	128CX01CM	139,95



The LSL Superbike handlebar is shown in grey as reference.

_ X02 NAKED BIKE

The favourite for naked bikes.

black	pearl blasted	128AX02SW	89,95
silver	pearl blasted	128AX02SI	89,95



The LSL Superbike handlebar is shown in grey as reference.

The C02 Craft Bar® in 32.0 mm!



_ C02 CRAFT BAR®

The 32.0 mm handlebar for the present BMW models.

black	pearl blasted	129AC02MB	119,95
-------	---------------	-----------	--------

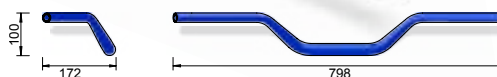

The LSL Superbike handlebar is shown in grey as reference.

28.6 mm CLAMPS -
SPACER BLOCKS

- _ bring up the handlebar position
- _ CNC-machined aluminum spacers, which are mounted into the original handlebar clamping
- _ Raising of the handlebar position by 25 mm and 30 mm, for Triumph handlebar 25 mm
- _ Pitch for the screw in the handlebar base 39 mm
- _ Clamps for Ducati also available in black
- _ Parts COC in connection with all LSL handlebar versions; ABE-approval in preparation

model	height	colour	item no	EUR
spacer blocks 28.6 mm				
Ducati	+ 30 mm	black	127RD30SW	49,95
Ducati	+ 30 mm	silver	127RD30SI	49,95
Street Triple	+ 25 mm	silver	127RD25T	49,95
Speed Triple 08-	+ 25 mm	silver	127RD25T	49,95



127RD...

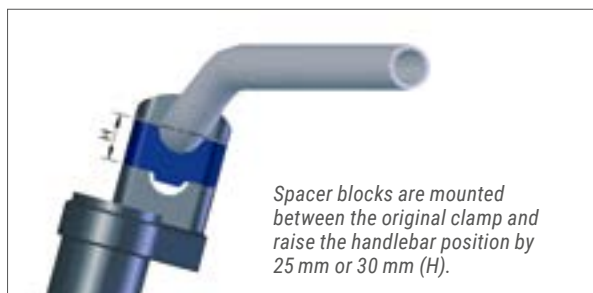

Spacer blocks are mounted between the original clamp and raise the handlebar position by 25 mm or 30 mm (H).

28.6 mm CLAMPS -
RISEUP BLOCKS

Bring the handlebar position higher and closer to the rider. For models with 28.6 mm clamping only.

- _ CNC-machined aluminum clamps, which are mounted into the original handlebar clamping
- _ Offset 25 mm high and 16 mm backwards
- _ Pitch for the screw in the handlebar base 39 mm - 40 mm
- _ Clamps optionally anodized aluminum silver or black
- _ Parts COC in connection with all LSL handlebar versions; ABE-approval in preparation

model	closer	height	colour	item no	EUR
riseup blocks 28.6 mm					
universal	16 mm	25 mm	black	127RI28SW	89,95
universal	16 mm	25 mm	silver	127RI28SI	89,95



127RI28SI

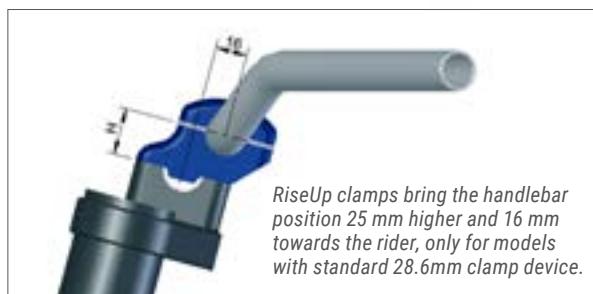

RiseUp clamps bring the handlebar position 25 mm higher and 16 mm towards the rider, only for models with standard 28.6mm clamp device.

28.6 mm CLAMPS -
ADAPTER BLOCKS

There are universal adapter clamps to assemble the 28.6 mm handlebar in fixed-cast 22 mm adapters, these are screwed into the handlebar mount.

- _ CNC machined handlebar clamps of high quality aluminum billet material
- _ Depending on the height of the adapter an increase of 25 mm is the result
- _ Clamps either aluminum silver or black anodized

mounting	height	colour	item no	EUR
adapter blocks				
suitable for original 22 mm	+ 25	black	127RK25SW	79,95
suitable for original 22 mm	+ 25	silver	127RK25SI	79,95



127RK25..



Conversion from 22.2mm handlebar to 28.6 mm X-Bar

_ HANDLEBAR **28.6 mm CLAMPS**

28.6 mm CLAMPS -
MODEL SPECIFIC

For the use of 28.6 mm handlebars LSL offers the necessary handlebar clamps for mounting in the original attachment points of the top yoke.

- _ Handlebar-clamps are elaborately CNC-machined out of high-quality alloy billet material.
- _ LSL clamps replace serial handlebar clamps to reach a different height and better design.
- _ LSL offers versions to convert 22.2 mm original clamping to 28.6 mm.



- _ For mounting use the original attachment points with centric located M10 x 1.25 mm screws; the series existing rubber mounting remains.
- _ Handlebar clamping height 45 mm; additional support (+15 or + 25 mm) available
- _ Handlebar clamps are available in aluminum silver or black-anodised
- _ Parts appraisals for many models; ABE-approval in combination with the 28.6 mm LSL handlebars.

bolting	silver	black	pair
universal, height of clamping 45 mm			
length 40 mm, M10 X 1.25	127X040SI	127X040SW	89,95
length 45 mm, M10 X 1.25	127X045SI	127X045SW	89,95
length 50 mm, M10 X 1.25	127X050SI	127X050SW	89,95
length 55 mm, M10 X 1.25	127X055SI	127X055SW	89,95
length 60 mm, M10 X 1.25	127X060SI	127X060SW	89,95
length 65 mm, M10 X 1.25	127X065SI	127X065SW	89,95
length 70 mm, M10 X 1.25	127X070SI	127X070SW	89,95
length 75 mm, M10 X 1.25	127X075SI	127X075SW	89,95
length 80 mm, M10 X 1.25	127X080SI	127X080SW	89,95
length 90 mm, M10 X 1.25	127X090SI	127X090SW	89,95



28.6 mm CLAMPS -
SPACER SET

When ordering the spacer sets please also order the corresponding longer screws.

This is how you measure the length of the screws:

Measure the length of the screw which shows of the original handlebar clamping. To that value 16 mm have to be added (= distance screw head to lower edge of LSL clamp) and possibly the thickness of the chosen support bushing.

height	silver	black	pair
support for raising			
+ 15 mm	127UN015SI	127UN015SW	9,95
+ 25 mm	127UN025SI	127UN025SW	9,95





28.6 mm CLAMPS - MODEL SPECIFIC

model	type	year	Δ	silver	black	EUR
Aprilia						
Shiver 750	RA	08-	+15	127A019SI	127A019SW	99,95
Dorsoduro	SM	08-	-	127A019SI	127A019SW	99,95
Tuono	RR	06-10	-2	127X070SI	127X070SW	89,95
Tuono V4R	TY	11-14	-	127A024SI	127A024SW	89,95
Tuono V4 1100	TY	15-	+5	127A024SI	127A024SW	89,95
BMW						
F 700 GS	E8GS	13-	-3	127B048SI	127B048SW	89,95
R 1200 R	R1ST	07-11	+25	127B042SI	127B042SW	89,95
R 1200 RS	R12WR	15-	-	127B052SI	-	79,95
Buell						
XB-9S/12S	XB1	all	+25	127BU05SI	127BU05SW	109,95
Ducati						
Monster 696	M5	08-	+10	127D036SI	127D036SW	89,95
Monster 821	M6	14-	+3	127D049SI	127D049SW	89,95
Scrambler Icon	K1	15-	+5	127D047SI	127D047SW	129,95
Monster 1100	M5	08-	+10	127D036SI	127D036SW	89,95
Multistr. 1200	A2	10-	+5	127D040SI	127D040SW	89,95
Honda						
Hornet 600	PC41	07-	+25	127RK25SI	127RK25SW	69,95
CBF 600S	PC43	08-	+25	127RK25SI	127RK25SW	69,95
CBF 1000	SC58	06-	+30	127T015SI	127T015SW	89,95
CBF 1000F	SC64	10-	+25	127RK25SI	127RK25SW	79,95
CBF 1000L	SD04	16-	+10	127H161SI	127H161SW	79,95
CB 1000R	SC60	08-12	+25	127RK25SI	127RK25SW	79,95
CB 1100	SC65	13-	+10	127H101SI	127H101SW	89,95
CB 1300	SC54	03-	+10	127H101SI	127H101SW	89,95
Husqvarna						
Nuda 900	A7	12-	-18	127HU02SI	127HU02SW	89,95
<i>does not work with original 28.6 mm handlebar</i>						
Kawasaki						
ER 6N	ER650C	09-	+15	127K133SI	127K133SW	89,95
ER 6f	EX650E	12-	+15	127K141SI	127K141SW	89,95
Z 750	ZR750J/L/M	04-	+15	127K102SI	127K102SW	89,95
Z 800	ZR800A	13-	-	127K133SI	127K133SW	89,95
Z 1000	ZRT00A/B	03-09	+15	127K102SI	127K102SW	89,95
Z 1000	ZRT00F*	14-	-	-	127K147SW	159,95
ZRX1100/1200	ZRT10C/20A	all	+20	127K082SI	127K082SW	89,95
Versys 1000	LZT00A/1	12-	+25	127RK25SI	127RK25SW	69,95
KTM						
125/ 200 / 390	Duke C3	13-	+10	127X075SI	127X075SW	89,95
Moto Guzzi						
V7	LW	08-	+17	127M018SI	127M018SW	89,95
Griso 1100	LS	06-	-10	127M017SI	127M017SW	89,95
V9 Bobber	LHA	16-	-	127M021SI	127M021SW	99,95
V11	KR	-	-	127M013SI	127M013SW	89,95

model	type	year	Δ	silver	black	EUR
Suzuki						
GSR 600	WVB9	06-	+25	127RK25SI	127RK25SW	69,95
GSF 600 Band.	GN77B/A8	95-04	+25	127RK25SI	127RK25SW	69,95
DL 650	WVB1	04-	+25	127RK25SI	127RK25SW	69,95
GSF 650 Band.	WVCJ	07-	+10	127X045SI	127X045SW	89,95
SV 650N	WVBY	03-08	+25	127RK25SI	127RK25SW	69,95
SFV650 Gladius	WVCX	09-	+25	127RK25SI	127RK25SW	69,95
GSR 750	C5	11-	+10	127S125SI	127S125SW	89,95
SV1000N	WVBX	03-	+3	127S095SI	127S095SW	89,95
DL1000 V-Strom	DD	14-	+13	127S125SI	127S125SW	89,95
GSF1200Band.	GV75A/9	all	+5	127X080SI	127X080SW	89,95
GSF 1250 Band.	WVCH	07-	+12	127X065SI	127X065SW	89,95
GSX1250F	WVCH	10-	+10	127S125SI	127S125SW	89,95
B-King	WVCR	07-	-8	127S119SI	127S119SW	89,95
GSX 1400	WVBN	all	+10	127S089SI	127S089SW	89,95
Triumph						
Street Tr. 675	D67LD	08-12	+10	127X080SI	127X080SW	89,95
Bonneville	986MF	07-15	+10	127T044SI	127T044SW	89,95
Scrambler	986MG	06-15	+10	127T044SI	127T044SW	89,95
Bonneville	986MF	07-15	+35	-	127T044-HSW	99,95
Scrambler	986MG	06-15	+35	-	127T044-HSW	99,95
Street Twin	DP01	16-	+7	127T068SI	127T068SW	99,95
Speed Triple	DP01	16-	+3	127T015SI	127T015SW	89,95
Speed Triple	595N	02-04	+3	127T015SI	127T015SW	89,95
Speed Tr. 1050	515NJ	05-11	+3	127T015SI	127T015SW	89,95
Speed Tr. 1050	515NV	11-	+11	127T040SI	127T040SW	89,95
Tiger 1050	115NG	07-10	+11	127T040SI	127T040SW	89,95
Yamaha						
XJ6 Div.	RJ19	09-	-10	127X075SI	127X075SW	89,95
FZ6	RJ07/RJ14	03-	+25	127RK25SI	127RK25SW	69,95
MT-07	RM041*	14-	-	127Y134SI	127Y134SW	129,95
FZ8/Fazer	RN25	10-	+20	127X075SI	127X075SW	89,95
MT-09	RN29*	14-	+5	-	127Y129SW	139,95
MT-09	RN29*	14-	+25	-	127Y129-HSW	139,95
FZ1 /Fazer	RN16	06-	-30	127X080SI	127X080SW	89,95
FZ1/FazerABS	RN16	06-	-5	127Y101SI	127Y101SW	89,95
FZS 1000 Fazer	RN06/14	-05	-5	127Y086SI	127Y086SW	89,95
BT1100 Bulldog	RP05	all	-50	127X080SI	127X080SW	89,95
XJR 1200/1300	all	all	+20	127X040SI	127X040SW	89,95
MT 01	RP12/18	all	-13	127Y101SI	127Y101SW	89,95
MT 01	RP12/18	all	-38	127Y101-LSI	127Y101-LSW	89,95
MT 10	RN451	16-	-17	127Y144SI	127Y144SW	89,95
XSR 700 ABS	RM11	15-	-	-	127Y141SW	129,95
XSR 900 ABS	RN431	16-	-	-	127Y143SW	in prep.

*incl. instruments bracket and aluminum cover

_ HANDLEBAR 22.2 mm STANDARD

LSL PERFORMANCE

Performance 22.2 mm Standard



- _ All 22.2 mm-handlebars tested by requirement of German TÜV-standard
- _ Regular COP-tests confirm constant quality
- _ Fitting ability to certain motorcycle models is tested at LSL workshop for a big range of models









STRONG ALUMINUM HANDLEBARS

- _ Extruded aluminum tube with a diameter of 22.2 mm, continuous wall thickness of 4.0 mm
- _ Material AlCuSiMn in Temper quality T6
- _ Surface depending on the color either polished or pearl-blasted, coloured anodized



CLASSIC STEEL HANDLEBARS

- _ High-strength steel tube with a diameter of 22.2 mm, continuous wall thickness of 2.0 mm
- _ Surface either black or chrome

COLOUR

aluminum handlebars	surface	order info
black		polished item no + SW
silver		polished item no + SI
gold		polished item no + GO
red		polished item no + RT
blue		polished item no + BL
titan		polished item no + TI
black		pearl blasted item no + MB

COLOUR

steel handlebars	surface	order info
black		silky shine item no + SW
chrome		item no + CR

DRILLING TEMPLATE - THE PROFESSIONAL TOOL SET

In order to ensure the firm seating of the switch assy, the holes for the original handlebar twist pins must be transferred to the new handlebar. With the LSL drill template you can easily transfer the distance dimension of the hole and while drilling it is fed through the bushing. (on page 47)





_ D1 DRAG BAR

Sporty narrow with 20° cranking

steel	chrome		123LD01CR	49,95
-------	--------	--	-----------	-------



The LSL Superbike handlebar is shown in grey as reference.



NEW Aluminium black pearl blasted



_ D2 DRAG BAR WIDE

The classic one for dragster and streetfighter.

steel	black	silky shine	123LD02SW	49,95
steel	chrome		123LD02CR	49,95
aluminium	black	polished	122AD02SW	59,95
aluminium	silver	polished	122AD02SI	59,95
aluminium	black	pearl blasted	122AD02MB	59,95

NEW



The LSL Superbike handlebar is shown in grey as reference.



_ 00 STREET BAR

The wide one for wheelies and other funny rides.

steel	black	silky shine	123L000SW	49,95
steel	chrome		123L000CR	49,95
aluminium	black	polished	122A000SW	59,95
aluminium	silver	polished	122A000SI	59,95
aluminium	gold	polished	122A000GO	59,95
aluminium	red	polished	122A000RT	59,95
aluminium	blue	polished	122A000BL	59,95
aluminium	black	pearl blasted	122A000MB	59,95



The LSL Superbike handlebar is shown in grey as reference.



_ 04 STREET BAR HIGH

The high variant of the Street Bar

aluminium	black	polished	122A004SW	59,95
aluminium	silver	polished	122A004SI	59,95
aluminium	gold	polished	122A004GO	59,95



The LSL Superbike handlebar is shown in grey as reference.

_ HANDLEBAR 22.2 mm STANDARD



_ S1 CLUBMAN®

The sportive bar for dynamic riders.

steel	black	silky shine	123LS01SW	49,95
steel	chrome		123LS01CR	49,95
aluminium	black	polished	122AS01SW	59,95
aluminium	silver	polished	122AS01SI	59,95
aluminium	gold	polished	122AS01GO	59,95

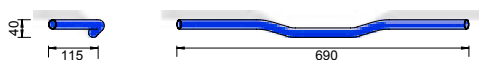

The LSL Superbike handlebar is shown in grey as reference.

NEW - now in chrome!



_ S2 BROOKS BAR

The cool-one for Classics

NEW

steel	black	silky shine	123LS02SW	59,95
steel	chrome		123LS02CR	59,95

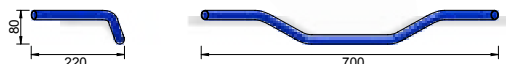

The LSL Superbike handlebar is shown in grey as reference.

LMB1 in 22.0 mm for BMW-Models



_ LMB1 FOR BMW-MODELS 22.0 mm

Especially prepared for the BMW Boxer with original end pieces or grip heater and necessary for the handlebar kit R 1100S.

steel	black	lackiert	123LMB1SW	99,95
steel	silver	lackiert	123LMB1SI	99,95



The LSL Superbike handlebar is shown in grey as reference.



N1 22.0 mm Superbike Flat for old BMW, Ducati and Moto Guzzi



_ N1 SUPERBIKE FLAT

Superbike Ergonomy slim and low

steel	black	silky shine	123LN01SW	49,95
steel	chrome		123LN01CR	49,95
aluminium	black	polished	122AN01SW	59,95
aluminium	silver	polished	122AN01SI	59,95
aluminium	gold	polished	122AN01GO	59,95
aluminium	red	polished	122AN01RT	59,95
aluminium	black	pearl blasted	122AN01MB	59,95

_ N1 22.0 mm SUPERBIKE FLAT

for old BMW, Ducati and Moto Guzzi

steel	chrome		123LN01CR-22	49,95	NEW
-------	--------	--	--------------	-------	------------

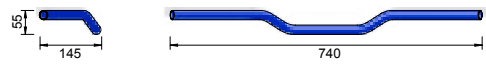

The LSL Superbike handlebar is shown in grey as reference.



_ 01 SUPERBIKE

Easy to handle, especially for superbikes.

steel	black	silky shine	123L001SW	49,95
steel	chrome		123L001CR	49,95
aluminium	black	polished	122A001SW	59,95
aluminium	silver	polished	122A001SI	59,95
aluminium	gold	polished	122A001GO	59,95
aluminium	red	polished	122A001RT	59,95
aluminium	blue	polished	122A001BL	59,95
aluminium	titan	polished	122A001TI	59,95
aluminium	black	pearl blasted	122A001MB	59,95

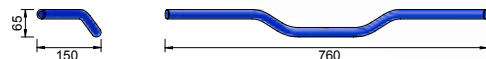

The LSL Superbike handlebar is shown in grey as reference.



_ 02 NAKED BIKE

The favourite for naked bikes.

steel	black	silky shine	123L002SW	54,95
steel	chrome		123L002CR	54,95
aluminium	black	polished	122A002SW	59,95
aluminium	silver	polished	122A002SI	59,95
aluminium	gold	polished	122A002GO	59,95
aluminium	blue	polished	122A002BL	59,95

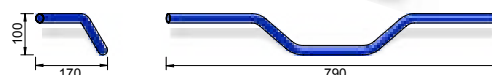

The LSL Superbike handlebar is shown in grey as reference.

_ HANDLEBAR 22.2 mm STANDARD



_ 03 TOUREN LENKER

Take a straight seat like on Z 900.

steel	chrome		123L003CR	59,95
-------	--------	--	-----------	-------

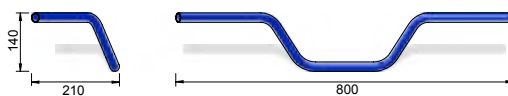

The LSL Superbike handlebar is shown in grey as reference.



_ 14 FLAT TRACK

The strong and wide one, not just for sand- or dirt-tracks.

steel	black	silky shine	123L014SW	59,95
steel	chrome		123L014CR	59,95

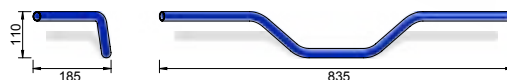

The LSL Superbike handlebar is shown in grey as reference.



_ 10 BUTTERFLY 22.0 mm

The great rolling one.
This handlebar has a wall thickness of 3 mm, so that an inner diameter of 16 mm Ø results.

steel	chrome		163L010.0CR	64,95
-------	--------	--	-------------	-------

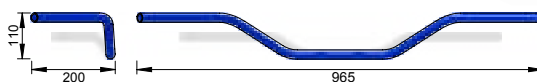

The LSL Superbike handlebar is shown in grey as reference.



NEW



Also for BMW models of the 90-ties (22.0 mm)

MX2 ENDURO HANDLEBAR

On many occasions we received the request to offer the classic Enduro handlebar with cross brace. Handlebars of the 70s as on the XT 500, or other Enduros of this time. With 22.0mm tube dimension this handlebar is perfectly suitable to upgrade BMW Boxer models of the

80s and 90s. The shape is very similar to the well-known Nakedbike handlebar, type "02", the ABE extension will include all models on which the "Naked Bike" has already been tested.

steel	black	silky shine	123LMX02SW	69,95
steel	chrome		123LMX02CR	69,95



The LSL Superbike handlebar is shown in grey as reference.

HANDLEBAR STRUT

Not only a visual accessory! The new LSL handlebar strut is a helpful reinforcement of the 22mm handlebars. Particularly sporty drivers from fast superbikes such as ZZR 1100, or Hajabusa can enjoy a noticeable gain at speed above 200 km / h.

Except on the 22mm handlebars the strut also fits to some conical handlebars. Please check the type overview for usage.

Strut: aluminum with 1/2" diameter
Clamps: CNC-milled and black anodised

The Cross-Bar fits the following LSL handlebars

XN1 Superbike Flat	Ø 28,6 mm	page 22
X01 Superbike	Ø 28,6 mm	page 22
X02 Naked Bike	Ø 28,6 mm	page 22
00 Street Bar	Ø 22,2 mm	page 27
04 Street Bar High	Ø 22,2 mm	page 27
LMB1 for BMW models	Ø 22,0 mm	page 28
01 Superbike	Ø 22,2 mm	page 29
02 Naked Bike	Ø 22,2 mm	page 29
03 Touren Lenker	Ø 22,2 mm	page 30
14 Flat Track	Ø 22,2 mm	page 30

handlebar strut	matt black	122ST01MB	19,95
-----------------	------------	-----------	-------



NEW

_ HANDLEBAR 22.2 mm CLAMPS



22.2 mm CLAMPS - SPACER BLOCKS

- _ Raise the handlebar position
- _ CNC-machined aluminum blocks, which are mounted into the original bar clamp
- _ Raising of bar position by 15, 25 and 35 mm
- _ Pitch for the screw fitting within the handlebar base 32-35 mm
- _ Spacer blocks in either silver or black
- _ Parts COC available in combination with all LSL handlebars; ABE-approval in preparation



model	height	colour	item no	EUR
spacer blocks 22.2 mm standard				
universal	15 mm	silver	121RD15SI	29,95
universal	15 mm	black	121RD15SW	29,95
universal	25 mm	silver	121RD25SI	29,95
universal	25 mm	black	121RD25SW	29,95
universal	35 mm	silver	121RD35SI	29,95
universal	35 mm	black	121RD35SW	29,95

22.2 mm CLAMPS - RISEUP BLOCKS

- _ Handlebar position higher and closer to the driver
- _ CNC-machined aluminum clamps, which are mounted into the original bar clamp
- _ Offset 25/35 mm high and 16 mm backwards
- _ Pitch for the screw fitting within the handlebar base 32-35 mm; Ducati special size 38 mm
- _ Clamps available in silver or black
- _ Parts COC available in combination with all LSL handlebars; ABE-approval in preparation



model	closer	higher	colour	item no	EUR
riseup blocks 22.2 mm standard					
universal	16 mm	25 mm	black	121RI25SW	59,95
universal	16 mm	25 mm	silver	121RI25SI	59,95
universal	16 mm	35 mm	black	121RI01SW	59,95
universal	16 mm	35 mm	silver	121RI01SI	59,95
Ducati	16 mm	30 mm	silver	121RI30DSI	59,95

22.2 mm CLAMPS - UNIVERSAL

- _ Original mounting points are used for fitting the M10 x 1.25 mm screws
- _ Parts COC in connection with LSL handlebars

product	height	colour	item no	EUR
universal clamps				
screws 60 mm	38 mm	silver	121KL60SI	89,95
screws 60 mm	38 mm	black	121KL60SW	89,95

22.2 mm CLAMPS - MODEL SPECIFIC

- _ Original mounting points are used for fitting the M10 x 1.25 mm screws
- _ Handlebar clamps CNC machined from billet aluminum
- _ Replacement of series clamps to achieve a different height and better optics
- _ Clamp height 35 mm
- _ A standard rubber support remains
- _ Clamps either silver or black
- _ ABE-approval in combination with LSL handlebars

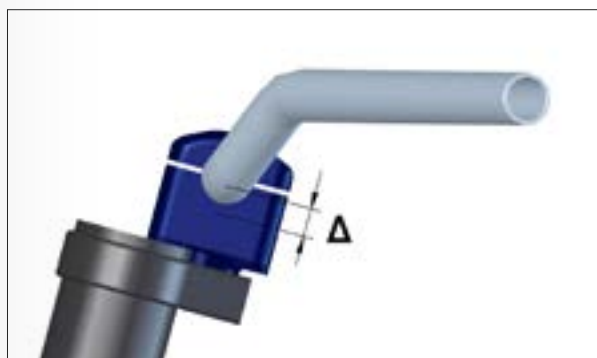

model	type	year	raise	black	silver	EUR
Honda						
CBF 1000	SC58	06-	+ 25 mm	-	121H111SI	89,95
CB 1100	SC65	13-	+ 15 mm	-	121S01SI	119,95
Kawasaki						
ER 6f	EX650E	12-	+ 8 mm	121K141SW	121K141SI	89,95
Z 750	ZR750J/L	04-07	+ 5 mm	-	121K102LSI	89,95
Z 750	ZR750J/L	04-07	+ 20 mm	121K102SW	121K102SI	89,95
Z 1000	ZRT00A/B	03-09	+ 5 mm	-	121K102LSI	89,95
Z 1000	ZRT00A/B	03-09	+ 20 mm	121K102SW	121K102SI	89,95
Moto Guzzi						
V11 Sport	KR	99-03	-	121M013SW	121M013SI	89,95
V9 Bobber	LHA	16-	-	121M021SW	121M021SI	99,95
V7	LW	08-	+ 11 mm	121M018SW	121M018SI	89,95
Suzuki						
GS 500	GM51B	89-00	-	-	121S036SI	89,95
GSF 1200 Bandit	all	all	+ 10 mm	121S064SW	121S064SI	89,95
Triumph						
Street Triple 675	D67LD	07-	+ 3 mm	-	121T041SI	89,95
Bonneville, cast wheel	986MF	08-15	+ 3 mm	121T044SW	121T044SI	89,95
Scrambler	986MG	06-15	+ 3 mm	121T044SW	121T044SI	89,95
Bonneville, cast wheel	986MF	08-15	+ 15 mm	121T044-HSW	121T044-HSI	99,95
Scrambler	986MG	06-15	+ 15 mm	121T044-HSW	121T044-HSI	99,95
Street Twin	DP01	16-	- 3 mm	121T068SW	127T068SI	99,95
Street Cup (conversion ø 22.2 mm)	DZ01	17-	- 3 mm	121T068SW	127T068SI	99,95
Thunderbird Sport	T309RT/RD	all	- 30 mm	121T020SW	121T020SI	89,95
Speed Triple/1050	T509	97-07	- 5 mm	121T015SW	121T015SI	89,95
Yamaha						
XJ6 Diversion	RJ19	09-	- 25 mm	-	121Y121SI	89,95
FZS 1000 Fazer	RN06	-05	- 20 mm	121Y086SW	121Y086SI	79,95
FZ1	RN16	06-	- 25 mm	121S064SW	121S064SI	89,95
BT 1100 Bulldog	RP05	all	- 45 mm	121Y091SW	121Y091SI	89,95
XJR 1200 /1300	all	all	+ 5 mm	-	121Y073SI	89,95
XJR 1200 /1300	all	all	+ 25 mm	-	121Y073-HSI	99,95
XSR 900 ABS	RN431	16-	- 25 mm	121Y143SW	121Y143SI	in prep.

NEW

_ HANDLEBAR 25.4 mm / 1 INCH



Performance 25.4 mm / 1 inch

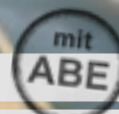

- _ All inch-handlebars are supplied with ABE-approval for many models of the recent years
- _ A registration pursuant to § 19.2 for not listed models is possible due to an agreement with the audit authority

LSL PERFORMANCE

STRONG ALUMINUM HANDLEBARS

Drawn aluminum tube with a diameter of 25.4 mm; wall thickness of 4.5 mm within the clamping area, within grip area conifed internally to 4.0 mm, material AlCuSiMn in Temper quality T6; surface depending on the color either polished or bead-blasted; anodized in four different versions.

COLOUR

aluminum handlebars	surface	order info
black		polished item no + SW
silver		polished item no + SI
gold		polished item no + GO
silver		pearl blasted item no + MS
black		pearl blasted item no + MB

LONG HOLES FOR CABLE ENTRY

Accordingly, the aluminum handlebars for Harley are available with slotted holes.



CLASSIC STEEL HANDLEBARS

Precision steel tube with a diameter of 25.4 mm, continuous wall thickness of 3.0 mm; surface either black or chrome.

steel handlebars	surface	order info
black		silky shine item no + SW
chrome		item no + CR

COLOUR

HARLEY DIMPLE

Especially for Harley we offer our steel handlebars with dimple, as well as the stock bars.





_ S1 CLUBMAN®

The proper inch-bar for sporty riding

steel	black	silky shine		163LS01.1SW	54,95
steel	chrome			163LS01.1CR	54,95
steel	black	silky shine	Harley dimple	163LS01.2SW	59,95
steel	chrome		Harley dimple	163LS01.2CR	59,95
aluminum	black	polished		162AS01.1SW	89,95
aluminum	gold	polished		162AS01.1GO	89,95
aluminum	black	pearl blasted		162AS01.1MB	89,95
aluminum	silver	pearl blasted		162AS01.1MS	89,95
aluminum	black	polished	Long hole	162AS01.4SW	99,95
aluminum	gold	polished	Long hole	162AS01.4GO	99,95
aluminum	black	pearl blasted	Long hole	162AS01.4MB	99,95
aluminum	silver	pearl blasted	Long hole	162AS01.4MS	99,95

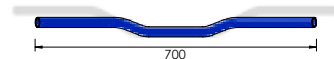
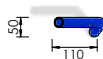

The LSL Superbike handlebar is shown in grey as reference.



_ D1 DRAG BAR

The classic one for Dragster.

steel	chrome			163LD01.1CR	54,95
-------	--------	--	--	-------------	-------

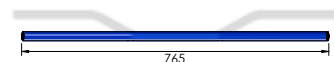

The LSL Superbike handlebar is shown in grey as reference.



_ D2 DRAG BAR WIDE

The straight bar - a must-have for Streetfighters

steel	black	silky shine		163LD02.1SW	54,95
steel	chrome			163LD02.1CR	54,95
steel	black	silky shine	Harley dimple	163LD02.2SW	59,95
steel	chrome		Harley dimple	163LD02.2CR	59,95
aluminum	black	polished		162AD02.1SW	89,95
aluminum	black	pearl blasted		162AD02.1MB	89,95
aluminum	black	polished	Long hole	162AD02.4SW	99,95
aluminum	black	pearl blasted	Long hole	162AD02.4MB	99,95
aluminum	silver	pearl blasted	Long hole	162AD02.4MS	99,95



The LSL Superbike handlebar is shown in grey as reference.

_ HANDLEBAR 25.4 mm / 1 INCH



_ 00 STREET BAR

Cool and wide, offers extreme riding pleasure.

steel	black	silky shine		163L000.1SW	59,95
steel	chrome			163L000.1CR	59,95
steel	black	silky shine	Harley dimple	163L000.2SW	64,95
steel	chrome		Harley dimple	163L000.2CR	64,95
aluminum	black	polished		162A000.1SW	89,95
aluminum	black	pearl blasted		162A000.1MB	89,95
aluminum	black	polished	Long hole	162A000.4SW	99,95
aluminum	gold	polished	Long hole	162A000.4GO	99,95
aluminum	black	pearl blasted	Long hole	162A000.4MB	99,95
aluminum	silver	pearl blasted	Long hole	162A000.4MS	99,95



The LSL Superbike handlebar is shown in grey as reference.

NEW

NEW - comes in april !



_ N1 SUPERBIKE

The handlebar for Thruxton street bar conversion

aluminum	black	polished		162AN01.1SW	89,95
aluminum	black	pearl blasted		162AN01.1MB	89,95



The LSL Superbike handlebar is shown in grey as reference.

_ 01 ROADSTER

For excellent handling.

steel	black	silky shine		163L001.1SW	59,95
steel	chrome			163L001.1CR	59,95
steel	black	silky shine	Harley dimple	163L001.2SW	64,95
steel	chrome		Harley dimple	163L001.2CR	64,95
aluminum	black	polished		162A001.1SW	89,95
aluminum	silver	pearl blasted		162A001.1MS	89,95
aluminum	black	pearl blasted		162A001.1MB	89,95
aluminum	black	polished	Long hole	162A001.4SW	99,95
aluminum	gold	polished	Long hole	162A001.4GO	99,95
aluminum	silver	pearl blasted	Long hole	162A001.4MS	99,95
aluminum	black	pearl blasted	Long hole	162A001.4MB	99,95



The LSL Superbike handlebar is shown in grey as reference.



_ 11 **WIDE BAR**

Extra wide.

steel	chrome			163L011.1CR	69,95
steel	black	lackiert		163L011.1SW	69,95
steel	chrome		Harley dimple	163L011.2CR	74,95
steel	black	lackiert	Harley dimple	163L011.2SW	74,95



The LSL Superbike handlebar is shown in grey as reference.



_ 10 **BUTTERFLY**

The great rolling one.

steel	chrome			163L010.1CR	69,95
steel	black	silky shine	Harley dimple	163L010.2SW	74,95
steel	chrome		Harley dimple	163L010.2CR	74,95



The LSL Superbike handlebar is shown in grey as reference.



_ 12 **OLD STYLE**

Styling like in the old days.

steel	chrome			163L012.1CR	74,95
steel	black	silky shine	Harley dimple	163L012.2SW	79,95
steel	chrome		Harley dimple	163L012.2CR	79,95



The LSL Superbike handlebar is shown in grey as reference.



_ 15 **SHUFFLE**

The strong cruiser.

steel	chrome		Harley dimple	163L015.2CR	74,95
-------	--------	--	---------------	-------------	-------



The LSL Superbike handlebar is shown in grey as reference.

_ HANDLEBAR 25.4 mm / 1 INCH



_ 14 FLAT TRACK

Absolute control, not just on the flat track.

steel	black	silky shine		163L014.1SW	69,95
steel	chrome			163L014.1CR	69,95
steel	black	silky shine	Harley dimple	163L014.2SW	74,95
steel	chrome		Harley dimple	163L014.2CR	74,95
aluminum	black	polished		162A014.1SW	89,95
aluminum	silver	pearl blasted		162A014.1MS	89,95

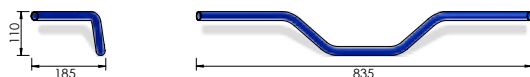

The LSL Superbike handlebar is shown in grey as reference.

DRILLING TEMPLATE -
THE PROFESSIONAL TOOL SET

In order to ensure the firm seating of the switch assy, the holes for the original handlebar twist pins must be transferred to the new handlebar. With the LSL drill template you can easily transfer the distance dimension of the hole and while drilling it is fed through the bushing. (on page 47)



_ HANDLEBAR 25.4 mm / 1 INCH CLAMPS



25.4 mm / 1 INCH CLAMPS - MODEL SPECIFIC

For the use of 28.6 mm handlebars LSL offers the necessary handlebar clamps for mounting in the original attachment points of the top yoke.

- _ Original mounting points are used for fitting the M10 x 1.25 mm screws
- _ Handlebar clamps CNC machined from billet aluminum
- _ Replacement of series clamps to achieve a different height and better optics

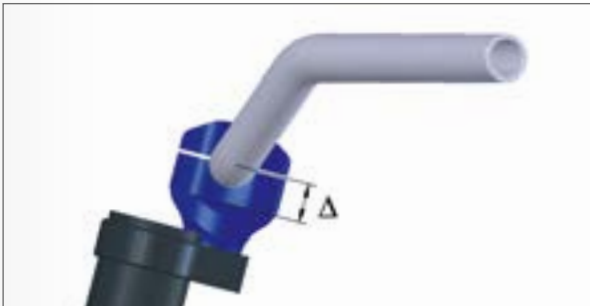

25.4 mm / 1 INCH CLAMPS - SPACER BLOCKS

Spacer blocks for Triumph Bonneville / Thruxton are mounted between the original clamping fixtures and raise the handlebar position by 25 mm.



model	year	Δ	colour	item no	EUR
Harley Davidson					
Sportster	-02	+ 10 mm	silver	161HD01SI	89,95
Sportster	-02	+ 10 mm	black	161HD01SW	89,95
Suzuki					
VL800 Intruder	01-	- 15 mm	silver	161S134SI	89,95
VL800 Intruder	01-	- 15 mm	black	161S134SW	89,95
Triumph					
Bonnev. spoke	-15	+ 10 mm	silver	161T043SI	89,95
Bonnev. spoke	-15	+ 10 mm	black	161T043SW	89,95
Bonnev. spoke	-15	+ 35 mm	silver	161T043-HSI	99,95
Bonnev. spoke	-15	+ 35 mm	black	161T043-HSW	99,95
Street Cup	17-	+ 5 mm	silver	161T069SI	99,95
Street Cup	17-	+ 5 mm	black	161T069SW	99,95
Bonnev. T100 /T120	16-	+ 5 mm	silver	161T069SI	99,95
Bonnev. T100 /T120	16-	+ 5 mm	black	161T069SW	99,95
Thruxton	08-15	- 5 mm	silver	161T043SI	89,95
Thruxton	08-15	- 5 mm	black	161T043SW	89,95
Thruxton	08-15	+ 20 mm	silver	161T043-HSI	99,95
Thruxton	08-15	+ 20 mm	black	161T043-HSW	99,95
Thunderb. Storm	11-	+ 25 mm	silver	161T062SI	99,95
Thunderb. Storm	11-	+ 25 mm	black	161T062SW	99,95

NEW
NEW

model	raiser	colour	item no	EUR
spacer blocks / 1 inch clamps				
Triumph	+ 25 mm	black	161RD25TSW	39,95



161RD25TSW

CLIP - ON





LSL **CLIP-ON**

The secret of the clip-on is the correct handlebar tube position. It is completely unnecessary for the manufacturers of extreme super sports bikes to take handlebar tube angle of ultra slim racing bikes of the 80s.

LSL has been working for many years with the determination of the correct wrist position. Therefore the LSL Sport Match versions combine the sporting demands of a low positioned clip-on with the opportunity to complete longer downhill stretches without tiring.

With this setup yo can certainly ride fast, this has been proven by many racing successes.

Performance Clip-on

- _ Stress optimized design of the machined clamps
- _ Ergonomic bar angle
- _ Clip-on tubes are changable, choose your favourite colour
- _ clip-on bars also in 25,4 mm / inch (1")

LSL PERFORMANCE



Photo: motorradrennen.com

Domminic Lammert on GSX-R 1000

_ CLIP-ON SPORT MATCH



SPORT MATCH
THE STYLISH RACING CLIP-ON

The Sport Match clip-on is the classic construction carrying the bars close to the stanchions. The bar angle is 5°.



SPEED MATCH
A COMPACT SPORTLER

A compact clip-on of medium bar height. Controls can be moved even further inwards. The bar angle is 4°.



OFFSET HIGH
THE NAME IS PROGRAM

The Offset High construction brings the clip-on grips forward and higher. These Offset High clamps are designed for sport bikes with high fitted RAM air-intakes. The bar angle is 5°.

SPORT MATCH MOUNTING KITS

For some models LSL offers already completed mounting kits. These complete sets include all additionally required components such as reservoir bracket or appropriate longer brake hoses. The mounting instructions describe the assembly very detailed.

If necessary please also order directly bar end pieces/ weights and new grips.

model	item no SI	item no SW	EUR/pair
Sport Match			
XJR 1300	15 -	153Y139S	153Y139SSW 249,00

model	item no SI	item no SW	EUR/pair
Speed Match			
BMW S1000RR	09-11	153B040R	153B040RSW 259,00
BMW R nineT	-14	153B049R	153B049RSW 279,00
CBR 500RA	13 - 15	153H142R	153H142RSW 229,00
ZX 10-R ABS	16-	153K152R	- 259,00
Bonneville/Thruxton	08 -	153T024R	153T024RSW 222,00
Thruxton	-07	153T031R	153T031RSW 185,00
Thruxton 1200	16-	153T072R	153T072RSW 289,00
Thruxton 1200 R	16-	153T071R	- 185,00
Daytona 675	09-12	153T045R	- 279,00
Daytona 675 R	13-	153T055R	- 279,00
YZF-R6	08 -	153Y118R	153Y118RSW 179,00
YZF-R1	09 - 14	153Y120R	153Y120RSW 179,00
YZF-R1	15 -	153Y137R	153Y137RSW 215,95

model	item no SI	item no SW	EUR/pair
Offset High			
Thruxton 1200	16-	153T072H	153T072HSW 299,00
Speed Triple 1050	-07	153T033H	153T033HSW 219,00
YZF-R1	02-03	153Y088H	153Y088HSW 329,00
YZF-R1	04-08	153Y094H	153Y094HSW 329,00

SPEED MATCH ADJUSTABLE HANDLEBAR CLAMPS

Initiated by the need for long-distance racing, LSL has been deploying adjustable handlebar clamps for international teams since last year. Now also private drivers will benefit from the quick-change clip-ons.

The original racing clamp will be available in the sizes 50, 51 and 55mm diameter. As with all other Sport Match clamps, the foldable clamp is universally combined with the LSL steering tubes.



NEW

This version is offered without TÜV certification and only for race track usage!

∅	colour	item no	EUR/pair
adjustable Speed Match handlebar clamps			
50 mm	silver	154SK50	249,00
51 mm	silver	154SK51	249,00
55 mm	silver	154SK55	249,00

Stunning crash - rider and clip-on clamp in shape!



Foto: Mark Pförtner

! Please order the clip on tubes and the clamps separately.

colour	length	item no	EUR/pair
standard 22.2 mm			
black	280 mm	154L01SW	39,95
silver	280 mm	154L01SI	39,95
gold	280 mm	154L01GO	39,95
red	280 mm	154L01RT	39,95
blue	280 mm	154L01BL	39,95
titan	280 mm	154L01TI	39,95
25.4 mm / 1 inch, clamping 22.2 mm			
black	270 mm	154L02SW	69,95
silver	270 mm	154L02SI	69,95
fluid reservoir bracket			
universal		154-T22	10,95



TUBES PAIR

LSL Match clamps are nearly unbreakable. That's very important, not only on the race track. In case of damage you often have just to change one clip-on tube. The clip-on tubes are available as single spare part.



154-T22

Order info Sport Match:

Tubes + Match Version !

**MATCH VERSION
SPORT MATCH**



∅	colour	item no	EUR
Sport Match SM			
35 mm	silver	154SM35	119,00
35 mm	black	154SM35SW	119,00
38 mm	silver	154SM38	119,00
38 mm	black	154SM38SW	119,00
39 mm	silver	154SM39	119,00
39 mm	black	154SM39SW	119,00
40 mm	silver	154SM40	119,00
41 mm	silver	154SM41	119,00
41 mm	black	154SM41SW	119,00
43 mm	silver	154SM43	119,00
43 mm	black	154SM43SW	119,00
45 mm	silver	154SM45	119,00
48 mm	silver	154SM48	119,00
50 mm	silver	154SM50	119,00
50 mm	black	154SM50SW	119,00
51 mm	silver	154SM51	119,00
52 mm	silver	154SM52	119,00
53 mm	silver	154SM53	119,00
54 mm	silver	154SM54	119,00
55 mm	silver	154SM55	139,00
55 mm	black	154SM55SW	139,00

**MATCH VERSION
SPEED MATCH**



∅	colour	item no	EUR
Speed Match RS			
35 mm	silver	154RS35	139,00
36 mm	silver	154RS36	139,00
36 mm	black	154RS36SW	139,00
38 mm	silver	154RS38	139,00
39 mm	silver	154RS39	139,00
39 mm	black	154RS39SW	139,00
41 mm	silver	154RS41	139,00
41 mm	black	154RS41SW	139,00
42 mm	silver	154RS42	139,00
43 mm	silver	154RS43	139,00
43 mm	black	154RS43SW	139,00
50 mm	silver	154RS50	139,00
50 mm	black	154RS50SW	139,00
51 mm	silver	154RS51	139,00
52 mm	silver	154RS52	139,00
53 mm	silver	154RS53	139,00
55 mm	silver	154RS55	149,00
55 mm	black	154RS55SW	149,00
58 mm	silver	154RS58	179,00

**MATCH VERSION
OFFSET HIGH**



∅	colour	item no	EUR
Offset High OH			
39 mm	silver	154OH39	169,00
39 mm	black	154OH39SW	169,00
41 mm	silver	154OH41	169,00
41 mm	black	154OH41SW	169,00
43 mm	silver	154OH43	169,00
43 mm	black	154OH43SW	169,00
45 mm	silver	154OH45	169,00
46 mm	silver	154OH46	169,00
48 mm	silver	154OH48	169,00
50 mm	silver	154OH50	169,00
50 mm	black	154OH50SW	169,00
51 mm	silver	154OH51	169,00
52 mm	silver	154OH52	169,00
52 mm	black	154OH52SW	169,00
53 mm	silver	154OH53	169,00
54 mm	silver	154OH54	169,00
54 mm	black	154OH54SW	169,00
56 mm	silver	154OH56	199,00



Different sizes also available in black anodised

_ CLIP-ON TOUR MATCH



TOUR MATCH KIT

Comfortable and relaxing handlebar position: a duty for the LSL clip-on's Tour Match.

This back in the early 90's patented construction brings the steering tube handily over the top yoke, like no other handlebar.

The ideal steering tube angle ensures an optimum wrist position. This eliminates the need of adjusting the crank and lever positions are possible, which would not be realised with a complex adjustment mechanism.

A particularly light clip-on was created due to the load-optimized design of the holding clamp. The Tour Match combines high rigidity with surprisingly low weight; one side (Ø 46 mm) only has a weight of 460 g.

The Tour Match is supplied model-specific with all parts (assembly parts for hydraulic fluid reservoir and additional spacers for the fairing support) and TÜV certificate. The tubes are not model-specifically pre-drilled.



Performance Clip-on

- _ Perfect grip above the top yoke, ergonomic bar diameter.
- _ Fork clamp is made from high quality billet aluminum built for maximum load.
- _ Every clip-on comes with a bike specific mounting kit.



TOUR MATCH

The position is 70 mm higher and an additional 20 mm beyond the top yoke towards the rider (depending on the original position). This system provides a comfortable but even so very sporty seating position. Long tours can be driven as expeditiously as hot race track laps.

The moderate steering head angle of 1° relaxes the wrists, the unchanged handlebar width avoids wide in the wind hanging elbows.



TWIN MATCH

Modern fork constructions require further new steps of development. The solution for the S1000RR and RSV4 is the new Twin Match, a clip-on handlebar design that consists of two handlebar clamps, one positioned above and the other below the top yoke. Together there is a viable unit that brings the tube in the correct position.

The Twin Match will be delivered with a new bracket for the brake fluid reservoir and spacers that lift the fairing tips by app. 15 mm. The fairing body remains untouched.



TOP MATCH

LSL provides the Top Match for motorcycles with the handlebars above the top yoke.



MODELLSPEZIFISCHE
TOUR MATCH KITS



model	type	year	match version	mm higher	mm closer to rider	incl. brake lines	incl. clutch lines	steering stop	cut fairing/windscreen	item no	EUR
Aprilia											
SL 1000 Falco	PA	all	Tour Match	25	10					150A010	299,00
RSV 1000	RR	04-05	Tour Match	60	0	•				150A012	399,00
RSV 1000R /Factory	RR	06-	Tour Match	60	0	•				150A015	399,00
RSV 4 R	RK	10-	Twin Match	60	10	•	•			150A022	449,00
BMW											
S 1000RR ohne ABS		10-11	Twin Match	70	15					150B040	429,00
S 1000RR ABS	K10	12-14	Twin Match	70	15					150B043	429,00
R nineT	R1ST	14-	Tour Match	-125	-60			•		150B049	329,00
Ducati											
Sport 1000 /Biposto	C1	06-08	Tour Match	50	30					150D034	299,00
Honda											
CBR 500R	PC44	13-	Top Match	-5	-5			•		150H142	259,00
CBR 600F	PC25	91-98	Tour Match	30	30					150H046	429,00
CB 650F	RC74	14-	Top Match	25	5					150H156	259,00
CBR 900RR	SC28	92-95	Tour Match	30	0	•	•	•		150H047	399,00
CBR 900RR	SC33	96-97	Tour Match	30	0	•		•		150H072	359,00
CBR 900RR	SC33	98-99	Tour Match	30	0			•		150H082	319,00
CBR 900RR	SC44	00-01	Tour Match	30	0					150H090	299,00
CBR 900RR	SC50	02-03	Tour Match	30	0					150H096	299,00
VTR 1000F	SC36	97-06	Top Match	25	20			•	•	150H075	269,00
CBR 1000RR	SC57	04-05	Tour Match	70	40					150H103	299,00
CBR 1000RR	SC57	06-07	Tour Match	70	40	•	•			150H114	399,00
CBR 1000RR	SC59	08-	Tour Match	50	20	•				150H125	359,00
CBR 1000RR ABS	SC59	09-	Tour Match	50	20					150H131	319,00
CBR 1100XX	SC35	97-08	Top Match	35	30					150H074	269,00
Kawasaki											
ZX-10R	ZXT00C	04-05	Tour Match	75	30	•				150K105	379,00
KTM											
1190 RC8	KTMRC8	08-	Tour Match	30	10	•				150KT09	379,00
Suzuki											
SV 650S	AV	99-02	Tour Match	60	25	•				150S076	319,00
SV 650S /SA	WVBY	03-08	Tour Match	60	25					150S091	289,00
GSX-R 600 /750	WVB2 /B3	04-05	Tour Match	70	40	•				150S097	329,00
GSX-R 600 /750	WVCE/F/V/W	06-10	Tour Match	70	40	•				150S108	349,00
GSX-R 600 /750	C3 /C4	11-	Tour Match	60	15	•				150S127	349,00
GSX-R 750 /1000	WVBD /BL	01-02	Tour Match	20	40	•		•		150S082	329,00
GSX-R 1000	WVBZ	03-04	Tour Match	65	40	•	•	•		150S094	329,00
GSX-R 1000	WVB6	05-06	Tour Match	65	40	•	•			150S099	329,00
GSX-R 1000	WVCL	07-08	Tour Match	65	40	•	•			150S114	399,00
GSX-R 1000	WVCY	09-11	Tour Match	60	10	•		•		150S123	349,00
GSX-R 1000	WVCY	12-	Tour Match	60	10	•		•		150S130	349,00
GSX 1300R Hayabusa	A1	99-07	Tour Match	-30	0					150S077	299,00
Triumph											
Speed Four /TT 600	806LB	00-05	Top Match	50	20					150T022	249,00
Thruxton R	DE01/1/1	16-	Tour Match	0	-25					150T071	299,00
Thruxton	DE01/1/2	16-	Tour Match	-10	40					150T072	299,00
Daytona 675	D67LC	06-07	Tour Match	90	20			•		150T037	369,00
Daytona T595 /955i	T595	97-01	Tour Match	50	25					150T014	299,00
Daytona 955i	595N	02-05	Tour Match	50	25			•		150T025	299,00
Speed Triple 1050	515NJ	05-07	Tour Match	-	-					150T033	299,00
Speed Triple 1050	NJ2	08-11	Tour Match	-	-	•				150T042	349,00
Speed Triple R ABS	515NV	12-	Tour Match	-	-			•		150T064	299,00
<i>*in combination with other headlight brackets and ignition lock relocation only!</i>											
Yamaha											
SZR 660	4SU	97-	Tour Match	-	-	•			•	150Y072	329,00
YZF-R3	RH07	15-	Tour Match	25	-25					150Y140	289,00
YZF-R6	RJ11	06-07	Tour Match	85	10	•				150Y104	349,00
YZF 1000	4VD	all	Tour Match	60	20			•		150Y070	299,00
YZF-R1	RN01/04	98-01	Tour Match	85	10			•		150Y077	329,00
YZF-R1	RN09	02-03	Tour Match	85	10	•	•			150Y088	399,00
YZF-R1	RN22	09-	Tour Match	70	10	•		•		150Y120	379,00

NEW
NEW

COVERS **BARCLAMP HOLES**



model	year	item no	EUR
covers barclamp holes			
BMW R nineT	14-	144B049TSI	39,95

COVER **HEADLAMP MOUNTING**



model	year	item no	EUR
cover headlamp mounting			
BMW R nineT	14-	144B049BSI	39,95

ALUMINUM **HEAD NET**



thread	model	year	item no	EUR
aluminum head net				
M 20 x 1.0			318F020.1AN	6,95
M 22 x 1.0			318F022.3AN	10,95
M 24 x 1.0			818F024-8SI	10,95
M 25 x 1.0			318F025.3AN	10,95
M 25 x 1.0	Street Cup	17-	318T068AN	10,95
M 25 x 1.0	Bonneville T100	17-	318T068AN	10,95
M 25 x 1.0	Bonneville T120	16-	318T068AN	10,95
M 25 x 1.0	Thrupton 1200 /R	16-	318T071AN	10,95
M 25 x 1.0	Street Twin	16-	318T071AN	10,95

DRILLING TEMPLATE - **THE PROFESSIONAL TOOL SET**

In order to ensure the firm seating of the switch assy, the holes for the original handlebar twist pins must be transferred to the new handlebar. With the LSL drill template you can easily transfer the distance dimension of the hole and while drilling it is fed through the bushing. This template is designed for 5mm Ø drill bits.



handlebar-type	Ø drilling	item no	EUR
drilling template			
22.2 mm / X-Bar	5 mm	902DT01	29,95
25.4 mm 1 Inch	5 mm	902DT02	34,95
22.2 mm	4 mm (BMW)	902DT03	34,95

NEW



_ HANDLEBAR ACCESSORIES



! Clubman® Classic Grips also in inch dimension!



FOR THE CLASSICS CLUBMAN® CLASSIC GRIPS

In classical straight line, the Clubman grips (Ø 34mm) differ by strong material thickness and thereby improved damping quality.

The handle is fully in hand and underscores with his dark shade the classical appearance of the motorcycle.

	material	Ø inner	colour/hardness	length	item no	EUR/pair
Clubman classic grips						
	rubber	22 mm	black	120 mm	138CL02	24,95
NEW	rubber	1 Inch	black	120 mm	138CL01	24,95

All grips come with bar end caps.

STYLISH HANDLEBAR GRIPS - ALUMINUM AND RUBBER

Grippy rubber with stylish aluminum. Length 125 mm; suitable for 22 mm handlebar controls. Matching handlebar weights in same style and colours are also available. The weights are suitable for steel or aluminum handlebars.

COLOUR	aluminum-colour	surface	order info
	black		eloxiert item no + SW
	silver		eloxiert item no + SI
	gold		eloxiert item no + GO

	material	colour/surface	Ø inner	item no	EUR/pair
grips, length 125 mm					
	rubber/aluminum	black anodised		138G125SW	39,95
	rubber/aluminum	silver anodised		138G125SI	39,95
	rubber/aluminum	gold anodised		138G125GO	39,95
bar ends, outer Ø 35 mm, length 28 mm, 85 g p/pc					
	aluminum	black polished	14/18 mm	138LG1418SW	24,95
	aluminum	silver polished	14/18 mm	138LG1418SI	24,95
	aluminum	gold polished	14/18 mm	138LG1418GO	24,95



FOR SPORTS RIDERS LSL SPORT GRIPS

LSL has enlarged the offer of their sports grips.

Light-grey/soft or black/medium (smooth or resistant) available either in 125 mm or 120 mm length (the shorter Version fits Offroad- and most Yamaha models). Both Versions comes with groove for securing with steel wire.

	material	Ø inner	colour/hardness	length	item no	EUR/pair
LSL sport grips						
	rubber	22 mm	light grey/soft	125 mm	138RL01GR	19,95
	rubber	22 mm	black/medium	125 mm	138RL01SW	19,95
	rubber	22 mm	light grey/soft	120 mm	138RL02GR	19,95
	rubber	22 mm	black/medium	120 mm	138RL02SW	19,95



_ HANDLEBAR ACCESSORIES **BAR END WEIGHTS**

HANDLEBAR INNER Ø FOR



28.6 mm X-Bar handlebar = 14 mm

22.2 mm aluminum handlebar = 14 mm
22.2 mm steel handlebar = 18 mm

Zoll aluminum handlebar = 18 mm
Zoll steel handlebar = 19 mm



_ 1 **DUAL-DISE**

Bar-ends elaborated two-tone anodised. The second colour is always added to glossy black.

material	colour	surface	Ø	g p/pc	item no	pair
outer Ø 30 mm		length 40 mm				
aluminum	black	matt anodised	14/18	90 g	135-D07MB	39,95
aluminum	silver	matt anodised	14/18	90 g	135-D07SI	39,95
aluminum	gold	matt anodised	14/18	90 g	135-D07GO	39,95
aluminum	red	matt anodised	14/18	90 g	135-D07RT	39,95

NEW



_ 2 **TOUREN**

Heavy bar-weights, with 140 g per piece the heaviest in LSL program.

material	colour	surface	Ø	g p/pc	item no	pair
outer Ø 39 mm		length 38 mm				
aluminum	black	anodised	14/18	140 g	135-008SW	34,95
aluminum	silver	anodised	14/18	140 g	135-008SI	34,95

_ 3 **CYLINDRICAL SMALL**

Rounded small bar-ends with 22 mm handlebar diameter.



material	colour	surface	Ø	g p/pc	item no	pair
outer Ø 21 mm		length 16 mm				
aluminum	black	anodised	14 mm	35 g	135-004SW	19,95
aluminum	black	anodised	18 mm	35 g	135-001ASW	19,95
aluminum	silver	anodised	14 mm	35 g	135-004SI	19,95
aluminum	silver	anodised	18 mm	35 g	135-001ASI	19,95
aluminum	gold	anodised	14 mm	35 g	135-004GO	19,95
aluminum	gold	anodised	18 mm	35 g	135-001AGO	19,95
aluminum	red	anodised	14 mm	35 g	135-004RT	19,95
aluminum	red	anodised	18 mm	35 g	135-001ART	19,95
aluminum	blue	anodised	14 mm	35 g	135-004BL	19,95
aluminum	blue	anodised	18 mm	35 g	135-001ABL	19,95
aluminum	titan	anodised	14 mm	35 g	135-004TI	19,95
aluminum	titan	anodised	18 mm	35 g	135-001ATI	19,95

_ 4 **CYLINDRICAL BIG WITH LOGO**

Colourful anodised bar-weights with 30mm diameter.



material	colour	surface	Ø	g/Stk.	item no	pair
outer Ø 30 mm		length 32 mm				
aluminum	black	anodised	14/18	90 g	135-006SW	19,95
aluminum	silver	anodised	14/18	90 g	135-006SI	19,95
aluminum	gold	anodised	14/18	90 g	135-006GO	19,95
aluminum	red	anodised	14/18	90 g	135-006RT	19,95
aluminum	blue	anodised	14/18	90 g	135-006BL	19,95

_ 6 **FLAT CAP**

Short caps, now always with LSL Logo

material	colour	surface	Ø	g p/pc	item no	pair
outer Ø 34 mm		length 10 mm				
aluminum	black	anodised	14 mm	50 g	135-005SW	19,95
aluminum	silver	anodised	14 mm	50 g	135-005SI	19,95
aluminum	gold	anodised	14 mm	50 g	135-005GO	19,95
aluminum	red	anodised	14 mm	50 g	135-005RT	19,95
aluminum	blue	anodised	14 mm	50 g	135-005BL	19,95
aluminum	titan	anodised	14 mm	50 g	135-005TI	19,95
steel	black	coated	14 mm	110 g	135-005FSW	19,95
steel	chrome	chromed	14 mm	110 g	135-005FCR	19,95
steel	black	coated	18 mm	115 g	135-0G5FSW	19,95
steel	chrome	chromed	18 mm	115 g	135-0G5FCR	19,95
steel	black	coated	19 mm	110 g	165-001SW	24,95
steel	chrome	chromed	19 mm	110 g	165-001	24,95



_ 7 **ELLIPTICAL**

The Classics, elliptical out of heavy steel material

material	colour	surface	Ø	g p/pc	item no	pair	
outer Ø 28 mm		length 35 mm					
steel	black	coated	14/18	190 g	135-003FSW	19,95	
NEW	steel	black matt	coated	14/18	190 g	135-003FMB	19,95
steel	chrome	chromed	14/18	190 g	135-003FCR	19,95	



_ 8 **CRASH BALLS**

The bar-ends in LSL axle ball design, available in all crash pad colours, chrome and in stainless steel.

material	colour	surface	Ø	g p/pc	item no	pair
outer Ø 38 mm		length 22 mm				
aluminum	black	anodised	14 mm	75 g	136AL14SW	29,95
aluminum	silver	anodised	14 mm	75 g	136AL14SI	29,95
aluminum	white	coated	14 mm	75 g	136AL14WT	29,95
aluminum	gold	anodised	14 mm	75 g	136AL14GO	29,95
aluminum	yellow	coated	14 mm	75 g	136AL14GE	29,95
aluminum	signalrot	coated	14 mm	75 g	136AL14SR	29,95
aluminum	red-lasur	coated	14 mm	75 g	136AL14RT	29,95
aluminum	blue-lasur	coated	14 mm	75 g	136AL14BL	29,95
aluminum	titan	anodised	14 mm	75 g	136AL14TI	29,95
aluminum	grün	coated	14 mm	75 g	136AL14GR	29,95
aluminum	orange	coated	14 mm	75 g	136AL14OR	29,95
steel	black	coated	14 mm	145 g	136FE14SW	29,95
steel	chrome	chromed	14 mm	145 g	136FE14CR	29,95
stainless steel		CNC face	14 mm	150 g	136VA14	29,95



available in all crash pad colours

_ 9 **HANDLEBAR EXTENSIONS**

Special handlebar extensions to widen a handlebar grip area.

handlebar type	Innen Ø	length	item no	EUR/pair
for 22.2 mm handlebar				
aluminum	22.2 mm	14 mm	35 mm	135-LV4SW 29,95
steel	22.2 mm	18 mm	35 mm	135-LV5SW 29,95



BAR END WEIGHTS WITH BRASS SPREADER

The end pieces are used for mounting our bar end mirrors or LSL-lever protectors. The extension of the handlebar by 20 mm allows the mounting without moving the handlebar controls. It is mounted with a stable brass spreading clamp and ensures a tight fit of the assembled parts.



_1 165-LV2SW



_2 165-LV3SW



_3 165-LV4SW

BAR END WEIGHTS MODEL SPECIFIC

LSL adjusted the bar end pieces for the most common Piaggio and Vespa scooter models. With these you can even mount the bar end mirrors or lever protectors perfectly.



_4 165LVKT16 / 165LVT50



_5 165LVV02 / 165LVM18

FOR BAR END WEIGHTS LEVER GUARDS

LSL developed the new lever guards for active racing use. These protectors are required in almost all motorcycle racing classes. They prevent the contact of the lever with another motorcycle which could lead to a blocking of the front



product	inner Ø	item no	EUR/pair
bar end weights for LSL handlebars			
1 22.2 mm aluminum handlebars	14 mm	165-LV2SW	29,95
2 22.2 mm steel handlebars	18 mm	165-LV3SW	29,95
3 25.4 mm/1 inch aluminum handlebars	17 mm	165-LV4SW	29,95
2 25.4 mm/1 inch steel handlebars	18 mm	165-LV3SW	29,95
1 28.6 mm aluminum handlebars	14 mm	165-LV2SW	29,95

model	inner Ø	item no	EUR/pair
KTM			
4 KTM Duke 390	for original handlebar	165LVKT16	29,95
Moto Guzzi			
5 V7 / V7 II	with thread for series	165LVM18	29,95
5 V9 Bobber / Roamer	with thread for series	165LVM18	29,95
5 Griso	with thread for series	165LVM18	29,95
5 California Audace	with thread for series	165LVM18	29,95
Piaggio			
5 MP3 125-500	with thread for series	165LVV02	29,95
Triumph			
4 Thruxton 08-15	with thread for series	165LVT50	29,95
Vespa			
1 GTS	with thread for series	165LVV02	29,95
1 GTV 125-300	with thread for series	165LVV02	29,95
3 LX / LXV	17 mm	165-LV4SW	29,95
3 S 50-125	17 mm	165-LV4SW	29,95
Yamaha			
3 MT-07/ MT-09/ MT-10	M16 x 1.5 thread for series	165LVY129	in prep.

NEW

NEW

brake and would cause a fall. LSL equips the Street Triple Cup with its lever guards and many other parts. The lever protectors are available for both levers. Optional bar end pieces allow to assemble without offsetting the handlebar controls.



product	item no	EUR
LSL lever guards length 150 mm		
brake side	580L025RSW	69,95
clutch side	580L025LSW	69,95

All bar end mirrors fit to all LSL handlebar dimensions.



CLUBMAN® BAR END



The classic elegant Clubman® mirror for mounting on the handlebar. It is clamped to the steering tube and fits on 22 mm and 1" handlebars. Due to the corrosion-resistant stainless steel ball joint a large adjustment range is the result. The optional bar end pieces make the displacement of the handlebars unnecessary.

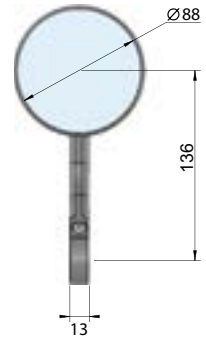

CLUBMAN® EMARK BAR END



This version has a larger mirror surface and meets the ECE standard. Due to the corrosion-resistant stainless steel ball joint a large adjustment range is the result. The optional bar end pieces make the displacement of the handlebars unnecessary. It fits 22 mm and 1" handlebars.

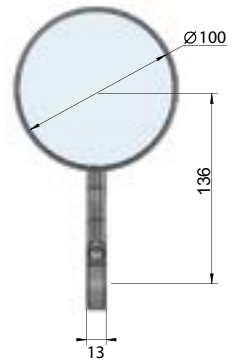

GONIA® BAR END



LSL offers an extra-small bar end mirror in the shape of GONIA®. It is connected to the steering tube and it can be mounted left and right. Optional bar ends are available to mount the mirrors easily without changing the controls. The included adapter bushing makes it fit to 22.2 mm and 1" handlebars.

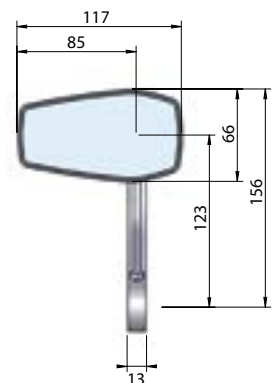

product	colour	position	handlebar type	item no	EUR p/pc
Clubman bar end					
version according European standard	black	left + right	22.2 mm / X-Bar / 1 inch	132SE02SW	59,95
Clubman eMark bar end					
ECE permission	black	left + right	22.2 mm / X-Bar / 1 inch	132SE03SW	79,95
Gonia bar end					
not allowed in area of german StVZO	black	left + right	22.2 mm / X-Bar / 1 inch	132SE01SW	69,95



GONIA®

Solid high-end aluminum manufactured mirror. The wide adjustment range results from the corrosion-resistant stainless steel ball joint. Thanks to a 74 cm² mirror surface mirror meets German ABE-regulation. Thread M10 x 1.25, left and right hand mounting in silver or black anodised.

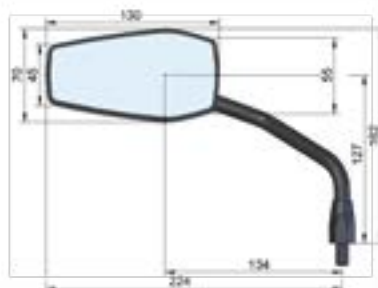

GONIA® EMARK

The popular handlebar mirror Gonia is also available with ECE approval. Like the smaller version Gonia, also eMark is machined of high value aluminum. The corrosion-resistant stainless steel ball joint allows an extremely large adjustment range. Thread M10 x 1.25, left and right hand mounting in silver or black anodised.

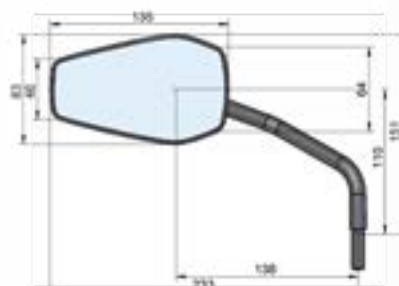

permission	colour	position	thread	handlebar type	item no	EUR p/pc
Gonia						
for bike with German ABE permission	silver	left	M10 x 1.25	all	132SD01LSI	69,95
for bike with German ABE permission	silver	right	M10 x 1.25	all	132SD01RSI	69,95
for bike with German ABE permission	black	left	M10 x 1.25	all	132SD01LSW	69,95
for bike with German ABE permission	black	right	M10 x 1.25	all	132SD01RSW	69,95
Gonia eMark						
ECE permission	silver	left	M10 x 1.25	all	132SD02LSI	89,95
ECE permission	silver	right	M10 x 1.25	all	132SD02RSI	89,95
ECE permission	black	left	M10 x 1.25	all	132SD02LSW	89,95
ECE permission	black	right	M10 x 1.25	all	132SD02RSW	89,95



CLUBMAN®

The round shaped Clubman mirror fits perfectly to classic motorcycle styles and conversions. The stainless steel globe joint allows a great adjustment range. It also protects against corrosion. A laser engraving LSL logo is a noble detail.

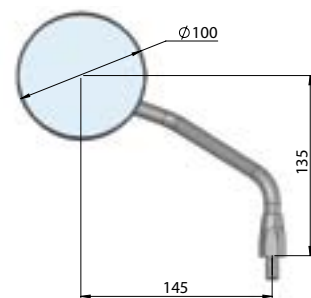

FLAME SUPERBIKE

The Flame mirror is our favourite for superbikes. The shape of the light weight and sporty plastic housing gives a maximum of view area to you. Thread M10 x 1.25; mirror surface 112 x 80 mm; ECE permission.



permission	colour	position	thread	handlebar type	item no	EUR p/pc
Clubman						
ECE permission	silver	left	M10 x 1.25	all	132SC01LSI	79,95
ECE permission	silver	right	M10 x 1.25	all	132SC01RSI	79,95
ECE permission	black	left	M10 x 1.25	all	132SC01LSW	79,95
ECE permission	black	right	M10 x 1.25	all	132SC01RSW	79,95
ECE permission	black	right	left M10 x 1.25	all	132SC01R-L-SW	79,95
Flame						
ECE permission	black	left + right	M10 x 1.25	all	131-F01SW	18,95

NEW

_ HANDLEBAR ACCESSORIES MIRRORS BRACKET KITS

_ 1 / 2 MIRROR ADAPTER & THREAD COVER



_ 1 ALUMINUM-THREAD COVER

Closes the 10mm mirror thread, an o-ring keeps the plug tight.



_ 1 MIRROR SCREW

For mounting of attachments in the mirror threads.



NEW

_ 2 ADAPTERKIT LEFT TREAD

Adapter for mounting Standard M10x1.25-mirrors on right side of Yamaha and KTM-Models.

type	thread	item no	count	EUR
1 thread cover to close mirror threads which are not in use				
LSL Logo	M10	131VS010SW	p/pc	7,95
Locking Screw DIN 6912	M10 x 1.25	811F1016SW	p/pc	4,90
NEW 2 adapterkit left tread (Yamaha, KTM ...)				
mirros adapterkit left tread on right side	M10 x 1.25 left/right	130SAL3SW	set	24,95

_ 4 / 5 MIRROR BRACKETS



_ 4 MIRROR BRACKET SP1

Single bracket M10 x 1.25



_ 4 MIRROR BRACKET SET SP1

Set of two brackets M10 x 1.25



_ 4 MIRROR BRACKET P2.1

Mirror bracket M10 x 1.25 for 22 mm handlebar



_ 5 MIRROR ADAPTER Triumph

Adapter M10x1.25 for the controls of Triumph Modern Classics



NEW

_ 5 MIRROR ADAPTER BMW-classics

Mirror adapters M10 x 1.25 for BMW young-timer



_ 5 MIRROR ADAPTER Harley-Davidson

Mirror adapters M10 x 1.25 Harley Davidson chrome plated steel

type	year	variant	thread	item no	count	EUR
4 mirror brackets						
SP1		1 bracket	M10 x 1.25	131SP01	p/pc	14,95
SP1 set		2 brackets	M10 x 1.25	130SP01	pair	29,95
SP2.1		mirror clamp	M10 x 1.25	131SP02.1	p/pc	22,95
5 mirror adapter M10 x 1.25						
Bonneville, spoke wheel			M10 x 1.25	130SAT1	pair	19,95
Thruxton	08-		M10 x 1.25	130SAT1	pair	19,95
NEW BMW R80/100			M10 x 1.25	130SAB4SW	pair	24,95
Harley-Davidson			M10 x 1.25	130SAHD	pair	19,95

_ 6 / 7 MIRROR BRACKET SETS



_ 6 MIRROR BRACKET SET SP3.1

Mirror bracket M10 x 1.25
for clutch cable GSX-R



_ 6 MIRROR BRACKET SET SP3.2

Mirror bracket M10 x 1.25
for clutch cable YZF-R1



_ 6 MIRROR BRACKET SET SP3.3

Mirror bracket M10 x 1.25
for clutch cable YZF-R1



_ 7 MIRROR BRACKET

Mirror bracket M10 x 1.25, brake and clutch
side



_ 7 MIRROR BRACKET SET

Mirror bracket set with fairing covers



_ 7 DISTANCE BLOCKS

Distance blocks for original mirror
for BMW K 1200 S / 1300 S



NEW

_ 7 MIRROR ADAPTER Thruxton 1200 R

Adapterset for Thruxton 1200 R standard
mirrors



NEW

_ 7 MIRROR ADAPTER Thruxton 1200

Adapterset for Thruxton 1200 standard
mirrors



_ 8 MIRROR EXTENSION

Moves the mirror 40 mm outwards and
35 mm higher. Thread: M10 x 1.25 left,
M10 x 1.50

type	year	variant	thread	item no	count	EUR
6 mirror brackets						
SP3.1	GSX-R	cable control	M10 x 1.25	131SP03.1	set	29,95
SP3.2	YZF-R1	98-99 cable control	M10 x 1.25	131SP03.2	set	29,95
SP3.3	YZF-R1	00- cable control	M10 x 1.25	131SP03.3	set	29,95
7 mirror bracket sets						
BMW, M5 screwing			M10 x 1.25	130SAB1	pair	34,95
BMW, M6 screwing			M10 x 1.25	130SAB2	pair	34,95
BMW R nineT / R 1200 R			M10 x 1.25	130SAB3	pair	34,95
BMW K 1200 S / 1300 S		distance blocks	-	130B028	set	69,95
Husqvarna			M10 x 1.25	130SAHU	pair	34,95
Suzuki GSX 1300 R	08-		M10 x 1.25	130S120	set	29,95
Triumph Bonneville T120 / T100	16-		M10 x 1.25	130T069SW	pair	in prep.
Thruxton 1200	16-	for original standard mirrors	inside Ø 17 mm	130T072SW	pair	39,95
Thruxton 1200 R	16-	for original standard mirrors	inside Ø 14 mm	130T071SW	pair	39,95
Yamaha YZF-R1	02-05	incl. cover	M10 x 1.25	130Y088	set	79,95
Yamaha YZF-R1	06	incl. cover	M10 x 1.25	130Y108	set	79,95
Yamaha YZF-R1	09	incl. cover	M10 x 1.25	130Y120	set	79,95
Yamaha FZS 1000 Fazer		incl. cover	M10 x 1.25	130Y086	set	79,95
8 mirror extension						
Standard			M10 x 1.25	130SA40	pair	29,95
BMW			M10 x 1.50	130SB40	pair	29,95
Yamaha, KTM...			M10 x 1.25 left/right	130SA40L	pair	29,95

NEW

NEW

NEW

_ BRAKE SYSTEM





LEVERS FOR MORE THAN 400 MODELS!

BRAKE AND CLUTCH LEVER

The right ergonomic shape, lever length and rounding-off provide the optimal combination for brake and clutch performance. For all hand sizes, the positioning of the lever is adjustable in 6 different positions.

The adjusting ellipse is supported with ball bearings. The adjusting lever, with its protruding top, is especially grippy and also allows adjustment during riding. The bearings of the lever mechanics are made from long-life brass. A generous recess at the end of the lever (long- and X-Version) serves

Performance Lever

The LSL lever passed through a very intensive test programme at TÜV Rheinland (German quality certification organisation). The certificate at „TÜV.com“ stands for high quality.

LSL PERFORMANCE

as predetermined breaking point and thus enables even after falling the sufficient function of the lever.



positions of clutch lever:
1-4 closer; 5 app. original position; 6 further



positions of brake lever:
1 closer; 2 app. original position; 3-6 further

The standard version of the LSL lever is made to be accessed by the whole hand. The short version is best suited to well-functioning brakes and can accommodate a three finger grip. This short version also comes with ABE-approval (for German permission).

The levers are equipped standard with red adjusters. The adjusters can be selected optionally in gold, blue, silver, anthracite or black. No extra costs.

Lever Extreme X



Original Lever



Lever engagement long version



Lever engagement short version



For various Harley and Victory models and the new BMW R nineT

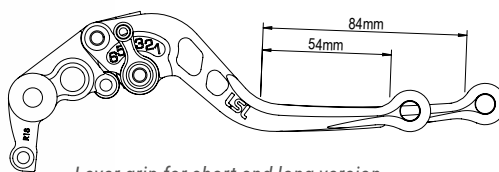

Lever grip for short and long version









_ BRAKE SYSTEM LEVER

ORDER INSTRUCTIONS BRAKE AND CLUTCH LEVER

The levers are equipped from the factory with red adjusting levers. The equipment can be selected with optional gold, blue, silver or black adjusting levers when ordering at no extra cost.

The adjuster set in different colours can be ordered separately.

! choose the lever colour **(+)** Adjusters also available in more colours (without surcharge)

LEVER	lever colours		Standard comes with red adjusters		adjuster colours		please add to the lever article-No.		ADJUSTER
	black		item no	lever .. SW	black		lever and	200+SW	
	silver		item no	lever .. SI	silver		lever and	200+SI	
	gold		item no	lever .. GO	gold		lever and	200+GO	
	anthracite		item no	lever .. AN	anthracite		lever and	200+AN	
					blue		lever and	200+BL	

model	type	year	lever				EUR	p/pc
/... = also for this model (ABS) = also for models with ABS ABS = for models with ABS only			colours: silver: SI; anthracite: AN; black: SW; gold: GO (please complete item no) The adjusters are available in different colours, please see above					
			clutch lever		brake lever			
			long	short	long	short		
Aprilia								
SL 750 Shiver /GT (ABS)	RA	07 -	200-L31...	200SL31...	200-R31...	200SR31...	99,95	
SMV 750 Dorsoduro (ABS)	SM	08 -	200-L31...	200SL31...	200-R31...	200SR31...	99,95	
NA 850 Mana /GT (ABS)	RC	07 -	-	-	200-R31...	200SR31...	99,95	
ETV 1000 Capo Nord (ABS)	PS	01 - 07	200-L13...	200SL13...	200-R22...	200SR22...	99,95	
RSV 1000 /R /Tuono	RP	01 - 04	200-L13...	200SL13...	200-R13...	200SR13...	99,95	
RSV 1000 /SP	ME	95 - 00	200-L13...	200SL13...	200-R13...	200SR13...	99,95	
RSV 1000R /Factory /Nera	RR	04 - 07	200-L25R...	200SL25R...	200-R23R...	200SR23R...	99,95	
RSV4 R	RK	09 - 13	200-L20...	200SL20...	200-R23R...	200SR23R...	99,95	
RSV4 R Factory	RK	09 - 12	200-L20...	200SL20...	200-R23R...	200SR23R...	99,95	
RSV4 R APRC	RK	10 -	200-L20...	200SL20...	200-R23R...	200SR23R...	99,95	
SL 1000 Falco	PA	01 - 05	200-L13...	200SL13...	200-R13...	200SR13...	99,95	
Tuono 1000R Factory	RR	05 - 10	200-L13...	200SL13...	200-R13...	200SR13...	99,95	
Tuono V4 R /APRC	TY	11 - 14	200-L20...	200SL20...	200-R13...	200SR13...	99,95	
Tuono V4 1100 RR /Factory	TY	15 -	200-L20...	200SL20...	200-R13...	200SR13...	99,95	
Dorsoduro 1200	TV	11 -	200-L13...	200SL13...	200-R13...	200SR13...	99,95	
Bimota								
DB 5 R/S	DB05	08 - / 06 -	200-L13...	200SL13...	200-R13...	200SR13...	99,95	
YB 8 Furano		92 - 93	200-L24...	200SL24...	200-R17...	200SR17...	99,95	
DB 6 Delirio	DB06	06 -	200-L13...	200SL13...	200-R13...	200SR13...	99,95	
BMW								
F 700GS	E8GS	13 -	200-L35R...	200SL35R...	200-R33...	200SR33...	99,95	
F 800S /ST /R/ GS (ABS)	E8ST	06 -	200-L35R...	200SL35R...	200-R33...	200SR33...	99,95	
F 800GS (ABS) w/ hand-protect	E8ST	08 -	-	200SL35R...	-	200SR33...	99,95	
S 1000R ABS	K10	13 -	200-L50...	200SL50...	200-R34R...	200SR34R...	99,95	
S 1000RR ABS	K10	10 - 14	200-L36...	200SL36...	200-R34R...	200SR34R...	99,95	
S 1000RR ABS	K10	15 -	200-L50...	200SL50...	200-R34R...	200SR34R...	99,95	
S 1000XR	K10	15 -	200-L56R...	200SL56R...	200-R53R...	200SR53R... **	99,95	
R nineT	R1ST	14 -	200-L44X...*	-	200-R44X...*	-	99,95	
K 1200S (ABS)	K12S	04 - 08	200-L34R...	200SL34R...	200-R33...	200SR33...	99,95	
K 1200R /Sport (ABS)	K12R	05 - 08	200-L34R...	200SL34R...	200-R33...	200SR33...	99,95	
R 1200GS /Adventure (ABS)	R12	04 - 12	200-L34...	200SL34...	200-R33...	200SR33...	99,95	
R 1200GS /Adventure (ABS) w/ hand-protect	R12	04 - 12	-	200SL34...	-	200SR33...	99,95	
R 1200R (ABS)	R1ST	06 -	200-L34...	200SL34...	200-R33...	200SR33...	99,95	
R 1200R (ABS) / RS	R12WR/0A04/4	15 -	200-L44X...*	-	200-R44X...*	-	99,95	
R 1200S (ABS)	R12S	07 -	200-L34...	200SL34...	200-R33...	200SR33...	99,95	
R 1200ST (ABS)	R1ST	05 - 09	200-L34...	200SL34...	200-R33...	200SR33...	99,95	
K 1300GT (ABS)	K12S	08 -	200-L34R...	200SL34R...	200-R33...	200SR33...	99,95	
K 1300R /S (ABS)	K12S	08 -	200-L34R...	200SL34R...	200-R33...	200SR33...	99,95	

* available lever colours: black or silver ** available lever colour: black

model	type	year	lever				EUR p/pc
<i>/... = also for this model</i> <i>(ABS) = also for models with ABS</i> <i>ABS = for models with ABS only</i>			<i>colours: silver: SI; anthracite: AN; black: SW; gold: GO (please complete item no)</i> <i>The adjusters are available in different colours, see page 60 please</i>				
			clutch lever		brake lever		
			long	short	long	short	
Brembo Pumpen							
Brembo Master Cylinder	15 RCS		-	-	200-R37R...	200SR37R...	99,95
Brembo Master Cylinder	19 RCS/17 RCS		-	-	200-R37R...	200SR37R...	99,95
Brembo Clutch Cylinder	16 RCS		200-L37R...	200SL37R...	-	-	99,95
Buell							
Firebolt XB 9 R	XB1	03 - 08	200-L11...	200SL11...	200-R20...	200SR20...	99,95
Lightning XB 9 S / City X	XB1	03 - 08	200-L11...	200SL11...	200-R20...	200SR20...	99,95
1125 R/CR	XB3	09 -	200-L24...	200SL24...	200-R17...	200SR17...	99,95
Cyclone M 2 / M 2-2	EB1	98 - 02	200-L11...	200SL11...	200-R17...	200SR17...	99,95
Firebolt XB 12 R	XB1	04 - 08	200-L11...	200SL11...	200-R20...	200SR20...	99,95
Lightning S 1 / S 1-2	EB1	98 - 02	200-L11...	200SL11...	200-R17...	200SR17...	99,95
Lightning X 1 / Millenium	BL1	99 - 02	200-L11...	200SL11...	200-R17...	200SR17...	99,95
Lightning XB 12 S /RRS /TT /Ss /Ss Long	XB1/2/3	04 -	200-L11...	200SL11...	200-R20...	200SR20...	99,95
Ducati							
Monster 400	M3	99 - 02	200-L12...	200SL12...	200-R12...	200SR12...	99,95
600 SS	S	95 - 98	200-L12...	200SL12...	200-R12...	200SR12...	99,95
Monster 600	M/M3	95 - 01	200-L12...	200SL12...	200-R12...	200SR12...	99,95
620 Super Sport i.E.	V5	03 - 07	200-L13...	200SL13...	200-R13...	200SR13...	99,95
Monster 620 i.E. /S /Dark	M4	02 - 06	200-L12...	200SL12...	200-R12...	200SR12...	99,95
Multistrada 620	A1	05 - 08	200-L12...	200SL12...	200-R12...	200SR12...	99,95
Monster 695 /696	M4 /M5	07 - 08 /08-	200-L12...	200SL12...	200-R12...	200SR12...	99,95
748 /R /S	H3	99 - 02	200-L13...	200SL13...	200-R13...	200SR13...	99,95
748 S /SP /Biposto	748	96 - 99	200-L12...	200SL12...	200-R12...	200SR12...	99,95
749 /R /S	H5	02 - 07	200-L25R...	200SL25R...	200-R23R...	200SR23R...	99,95
750 Super Sport	ZDM750SC/S	92 - 98	200-L12...	200SL12...	200-R12...	200SR12...	99,95
750 Super Sport i.E.	V2	99 - 02	200-L13...	200SL13...	200-R13...	200SR13...	99,95
Monster 750 /i.E.	M/M1/M4	98 - 02	200-L12...	200SL12...	200-R12...	200SR12...	99,95
800 Super Sport i.E.	V5	03 - 07	200-L12...	200SL12...	200-R12...	200SR12...	99,95
Monster 800 /S /S2R /Dark	M4	03 - 07	200-L12...	200SL12...	200-R12...	200SR12...	99,95
Monster 796	M5	10 -	200-L12...	200SL12...	200-R12...	200SR12...	99,95
Scrambrer Icon	K1	15 -	200-L51...	200SL51...	200-R12...	200SR12...	99,95
Monster 821	M6	14 -	200-L51...	200SL51...	200-R12...	200SR12...	99,95
848 /EVO	H6	08 -	200-L25R...	200SL25R...	200-R23R...	200SR23R...	99,95
Streetfighter 848	F1	12 -	200-L25R...	200SL25R...	200-R23R...	200SR23R...	99,95
Panigale 899	H8	14 -	200-L25R...	200SL25R...	200-R38R...	200SR38R...	99,95
900 Super Light/Super Sport	S/ZDM906SC2/3	91 - 98	200-L12...	200SL12...	200-R12...	200SR12...	99,95
900 Super Sport i.E.	V1	99 - 02	200-L13...	200SL13...	200-R13...	200SR13...	99,95
Monster 900	M	93 - 99	200-L12...	200SL12...	200-R12...	200SR12...	99,95
Monster 900 /i.E.	M2	00 - 02	200-L13...	200SL13...	200-R13...	200SR13...	99,95
916 S /SP /Biposto	916	95 - 97	200-L12...	200SL12...	200-R12...	200SR12...	99,95
ST 4 916	S2	99 - 03	200-L13...	200SL13...	200-R13...	200SR13...	99,95
Monster S4 /Fogarty /S4R	M4	00 - 03	200-L13...	200SL13...	200-R13...	200SR13...	99,95
ST 2 944	S1	98 - 03	200-L12...	200SL12...	200-R12...	200SR12...	99,95
ST 3 /S 992 (ABS)	S3	04 - 07	200-L13...	200SL13...	200-R13...	200SR13...	99,95
1000 SS /DS	V5	03 - 07	200-L13...	200SL13...	200-R13...	200SR13...	99,95
Sport 1000 /S	C1	06 - 09	200-L13...	200SL13...	200-R13...	200SR13...	99,95
Paul Smart 1000 LE	C1	06 - 09	200-L13...	200SL13...	200-R13...	200SR13...	99,95
GT 1000 /Touring	C1	07 - 10	200-L13...	200SL13...	200-R13...	200SR13...	99,95
Monster 1000 /S /Dark /S2R	M4	03 - 08	200-L13...	200SL13...	200-R13...	200SR13...	99,95
Multistrada 1000 /S /S DS	A1	03 - 06	200-L13...	200SL13...	200-R13...	200SR13...	99,95
996 /R /S	H2	98 - 01	200-L13...	200SL13...	200-R13...	200SR13...	99,95
ST 4 996	S2	01 - 03	200-L13...	200SL13...	200-R13...	200SR13...	99,95
ST 4S 996 (ABS)	S3	01 - 06	200-L13...	200SL13...	200-R13...	200SR13...	99,95
Monster S4R	M4	04 - 06	200-L13...	200SL13...	200-R13...	200SR13...	99,95
998 /R /S /Bayliss /Bostrom	H2	02 - 03	200-L13...	200SL13...	200-R13...	200SR13...	99,95
999 /R /S /Xerox	H4	03 - 06	200-L25R...	200SL25R...	200-R23R...	200SR23R...	99,95
Monster S4R S /Testastretta	M4	06 - 08	200-L25R...	200SL25R...	200-R23R...	200SR23R...	99,95
Monster S4R S Testastretta /Tricolore	M4	07 - 08	200-L25R...	200SL25R...	200-R23R...	200SR23R...	99,95
Hypermotard 1100 /S	B1	08 -	-	200SL25R...	-	200SR23R...	99,95
Monster 1100 /S /EVO (ABS)	M5	09 -	200-L25R...	200SL25R...	200-R23R...	200SR23R...	99,95
Multistrada 1100 /S	A1	07 - 09	200-L13...	200SL13...	200-R13...	200SR13...	99,95
1098 /S	H7	07 - 08	200-L25R...	200SL25R...	200-R23R...	200SR23R...	99,95
Streetfighter 1098 /S	F1	09 -	200-L25R...	200SL25R...	200-R23R...	200SR23R...	99,95
1098 R /Bayliss LE	H7	08 - 09	200-L25R...	200SL25R...	200-R23R...	200SR23R...	99,95
1198 /R /S /SP	H7	09 - 11	200-L25R...	200SL25R...	200-R23R...	200SR23R...	99,95
Panigale 1199 /S	H8	12 -	200-L25R...	200SL25R...	200-R38R...	200SR38R...	99,95
Diavel /Carbon /Cromo /AMG	G1	11 -	200-L25R...	200SL25R...	200-R23R...	200SR23R...	99,95
Multistrada 1200 /S (ABS)	A2	10 -	200-L25R...	200SL25R...	200-R23R...	200SR23R...	99,95
Monster 1200 /S	M6	14 -	200-L25R...	200SL25R...	200-R23R...	200SR23R...	99,95

_ BRAKE SYSTEM LEVER

model	type	year	lever				EUR	p/pc
			clutch lever		brake lever			
			long	short	long	short		
<i>colours: silver: SI; anthracite: AN; black: SW; gold: GO (please complete item no)</i> <i>The adjusters are available in different colours, see page 60 please</i>								
<i>/... = also for this model</i> <i>(ABS) = also for models with ABS</i> <i>ABS = for models with ABS only</i>								
Harley-Davidson (Hebel nur in black und silver lieferbar)								
XL 883 /1200	XL2	04-10	200-L41X...*	-	200-R41X...*	-		129,95
XL 883 /1200	XL2	11-	200-L41X...*	-	200-R46X...*	-		129,95
XR 1200	XL2	07-	200-L41X...*	-	200-R41X...*	-		129,95
XL1200CX Roaster ABS	XL2	14-	200-L41X...*	-	200-R46X...*	-		129,95
FXD Dyna Street Bob /Super Glide /Fat Bob	FD2	07-13	200-L41X...*	-	200-R41X...*	-		129,95
FXDL Dyna Low Rider	FD2	07-08	200-L41X...*	-	200-R41X...*	-		129,95
FXDB Dyna Street Bob	FD2	14-	200-L47X...*	-	200-R47X...*	-		129,95
<i>* available lever colours: black or silver</i>								
Honda								
CBR 250R /RA (ABS)	MC41	11 -	200-L09R...	200SL09R...	-	-		99,95
CB 500	PC26/32	94 - 96	200-L09R...	200SL09R...	200-R14...	200SR14...		99,95
CB 500 /S	PC32	97 - 03	200-L09R...	200SL09R...	-	-		99,95
CB 500FA	PC45	13 -	200-L39R...	200SL39R...	200-R39R...	200SR39R...		99,95
CBF 500 (ABS)	PC39	04 - 08	200-L14...	200SL14...	200-R14...	200SR14...		99,95
CBR 500RA	PC44	13 - 15	200-L39R...	200SL39R...	200-R39R...	200SR39R...		99,95
CB 600 F/S Hornet/Hornet-S	PC34/36	98 - 02	200-L09R...	200SL09R...	200-R14...	200SR14...		99,95
CB 600 F/S Hornet/Hornet-S	PC36	02 -	200-L09R...	200SL09R...	200-R14...	200SR14...		99,95
Hornet 600	PC36	03 - 06	200-L09R...	200SL09R...	200-R14...	200SR14...		99,95
Hornet 600 (ABS)	PC41	07 -	200-L33...	200SL33...	200-R14...	200SR14...		99,95
CBF 600 N/S (ABS)	PC38	04 - 07	200-L09R...	200SL09R...	200-R14...	200SR14...		99,95
CBF 600 N/S (ABS)	PC43	08 -	200-L33...	200SL33...	200-R14...	200SR14...		99,95
CBR 600 F	PC19/23/25	87 - 94	200-L14...	200SL14...	200-R14...	200SR14...		99,95
CBR 600 F	PC31/35	95 - 07	200-L09R...	200SL09R...	200-R14...	200SR14...		99,95
CBR 600 F (ABS)	PC41	11 -	200-L33...	200SL33...	200-R14...	200SR14...		99,95
CBR 600 RR	PC37	03 - 06	200-L15...	200SL15...	200-R15...	200SR15...		99,95
CBR 600 RR (ABS)	PC40	07 -	200-L15...	200SL15...	200-R16R...	200SR16R...		99,95
CB 650F	RC75	14 -	200-L46R...	200SL46R...	200-R14...	200SR14...		99,95
NT 650 Hawk	RC31	89 - 94	200-L09R...	200SL09R...	200-R14...	200SR14...		99,95
NT 650 V Deauville (CBS)	RC47	98 - 05	200-L09R...	200SL09R...	-	-		99,95
CBR 650	RC74	14 -	200-L46R...	200SL46R...	200-R14...	200SR14...		99,95
NC 700 SA /XA	RC61 /63	12 -	200-L09R...	200SL09R...	200-R14...	200SR14...		99,95
NC 750 S	RC70	14 - 15	200-L09R...	200SL09R...	200-R14...	200SR14...		99,95
NC 750 X	RC90	16 -	200-L46R...	200SL46R...	200-R14...	200SR14...		99,95
CB 750 Seven Fifty	RC42	92 - 02	200-L09R...	200SL09R...	200-R14...	200SR14...		99,95
RVF 750 R	RC45	94 - 97	200-L16...	200SL16...	200-R14...	200SR14...		99,95
VFR 750 F	RC36	90 - 97	200-L16...	200SL16...	200-R14...	200SR14...		99,95
VFR 800 F	RC46	98 - 01	200-L16...	200SL16...	200-R09...	200SR09...		99,95
VFR 800 F (ABS)	RC46	02 -	200-L16...	200SL16...	200-R14...	200SR14...		99,95
VFR 800 X Crossrunner (ABS)	RC80	15 -	200-L16...	200SL16...	200-R14...	200SR14...		99,95
CB 900 F Hornet	SC48	01 - 05	200-L09R...	200SL09R...	200-R14...	200SR14...		99,95
CBR 900 RR	SC28/33	92 - 99	200-L14...	200SL14...	200-R14...	200SR14...		99,95
CBR 900 RR	SC44	00 - 01	200-L14...	200SL14...	200-R15...	200SR15...		99,95
CBR 900 RR	SC50	02 - 03	200-L15...	200SL15...	200-R15...	200SR15...		99,95
CB 1000 F	SC30	93 - 96	200-L16...	200SL16...	200-R14...	200SR14...		99,95
CB 1000 R (ABS)	SC60	08 -	200-L16...	200SL16...	200-R16R...	200SR16R...		99,95
CBF 1000 (ABS)	SC58	06 -	200-L16...	200SL16...	200-R14...	200SR14...		99,95
CBF 1000 F (ABS)	SC64	10 -	200-L16...	200SL16...	200-R14...	200SR14...		99,95
CBR 1000 F	SC21/24	87 - 99	200-L16...	200SL16...	200-R14...	200SR14...		99,95
CBR 1000 RR	SC57	04 - 07	200-L16...	200SL16...	200-R16R...	200SR16R...		99,95
CBR 1000 RR (ABS)	SC59	08 -	200-L15...	200SL15...	200-R16R...	200SR16R...		99,95
CRF 1000L Africa Twin (ABS)	SD04	16 -	200-L57R...	200SL57R...	200-R14...	200SR14...		99,95
VTR 1000 F	SC36	97 - 06	200-L16...	200SL16...	200-R14...	200SR14...		99,95
VTR 1000 SP-1 /SP-2	SC45	00 - 05	200-L16...	200SL16...	200-R15...	200SR15...		99,95
Varadero 1000 (ABS)	SD01/SD02	99 -	-	-	200-R09...	200SR09...		99,95
CB 1100	SC65	13 -	200-L16...	200SL16...	200-R14...	200SR14...		99,95
CB 1100 SF X-11	SC42	00 - 03	200-L09R...	200SL09R...	200-R09...	200SR09...		99,95
CBR 1100 XX	SC35	97 - 07	200-L16...	200SL16...	200-R09...	200SR09...		99,95
ST 1100 Pan European (ABS)	SC26	90 - 02	200-L16...	200SL16...	200-R09...	200SR09...		99,95
VFR 1200F	SC63	10 -	200-L16...	200SL16...	200-R36...	200SR36...		99,95
VFR 1200FD with DCT	SC63	10 -	-	-	200-R36...	200SR36...		99,95
VFR 1200XD Crosstourer ABS	SC70C	15 -	200-L16...	200SL16...	200-R14...	200SR14...		99,95
CB 1300 F /S (ABS)	SC54	03 -	200-L16...	200SL16...	200-R14...	200SR14...		99,95
CB-X4 1300 DC	SC38	97 - 99	200-L16...	200SL16...	200-R14...	200SR14...		99,95
STX 1300 Pan European	SC51	02 -	200-L16...	200SL16...	200-R09...	200SR09...		99,95
Husqvarna								
Nuda 900 /R	A7	12 -	200-L35R...	200SL35R...	200-R23R...	200SR23R...		99,95
Indian								
Scout		15 -	200-L55R...	200SL55R...	200-R52R...	200SR52R...		99,95

model	type	year	lever		brake lever		EUR p/pc
			long	short	long	short	
<i>colours: silver: SI; anthracite: AN; black: SW; gold: GO (please complete item no) The adjusters are available in different colours, see page 60 please</i>							
<i>/... = also for this model (ABS) = also for models with ABS ABS = for models with ABS only</i>							
Kawasaki							
Ninja 300	EX300A	13 -	-	-	200-R39R...	200SR39R...	99,95
Z 300 (ABS)	ER300A	15 -	200-L52...	200SL52...	200-R39R...	200SR39R...	99,95
ZXR 400	ZX400L	91 - 00	200-L08...	200SL08...	200-R17...	200SR17...	99,95
ER-5	ER500A	97 - 05	200-L08...	200SL08...	200-R17...	200SR17...	99,95
GPZ 500S	EX500A/D	87 - 03	200-L08...	200SL08...	200-R17...	200SR17...	99,95
Zephyr 550	ZR550B	91 - 99	200-L08...	200SL08...	200-R17...	200SR17...	99,95
GPZ 600R	ZX600A	85 - 89	-	-	200-R17...	200SR17...	99,95
GPX 600R	ZX600A/C	88 - 99	-	-	200-R17...	200SR17...	99,95
ZZR 600	ZX600D/E	90 - 06	200-L08...	200SL08...	200-R17...	200SR17...	99,95
ZX-6R Ninja	ZX600F/G	95 - 99	200-L08...	200SL08...	200-R17...	200SR17...	99,95
ZX-6R Ninja	ZX600J	00 - 01	200-L17...	200SL17...	200-R17...	200SR17...	99,95
ZX-6RR Ninja	ZX600K	03 - 04	200-L17...	200SL17...	200-R17...	200SR17...	99,95
ZX-6RR Ninja	ZX600N	05	200-L17...	200SL17...	200-R18R...	200SR18R...	99,95
ZX-6R Ninja	ZX600P/R	07 -	200-L17...	200SL17...	200-R21...	200SR21...	99,95
ZX-6R Ninja	ZX636A/B	02 - 04	200-L17...	200SL17...	200-R17...	200SR17...	99,95
ZX-6R Ninja	ZX636C	05 - 06	200-L17...	200SL17...	200-R18R...	200SR18R...	99,95
ZX-6R 636 ABS Ninja	ZX636E	13 -	200-L17...	200SL17...	200-R21...	200SR21...	99,95
ER-6n/f (ABS)	ER/EX650A	06 - 08	200-L08...	200SL08...	200-R17...	200SR17...	99,95
ER-6n/f ABS	ER/EX650C/E	09 -	200-L08...	200SL08...	200-R32...	200SR32...	99,95
Versys 650 (ABS)	LE650A	07 - 08	200-L08...	200SL08...	200-R17...	200SR17...	99,95
Versys 650 ABS *from FIN: JKALE650ABA033001	LE650A/C	09 - 14	200-L08...	200SL08...	200-R32...	200SR32...	99,95
Versys 650 (ABS)	LE650E/F1/X	15 -	200-L08...	200SL08...	200-R20...	200SR20...	99,95
Vulcan S ABE	EN650A /D	15-16 / 17-	200-L08...	200SL08...	200-R20...	200SR20...	99,95
Z 650	Z650H	17 -	200-L08...	200SL08...	200-R20...	200SR20...	99,95
W 650	EJ650A	99 - 06	200-L38...	200SL38...	200-R17...	200SR17...	99,95
GPX/GPZ 750R	ZX750G/F	85 - 88	200-L24...	200SL24...	200-R17...	200SR17...	99,95
Z 750 /S	ZR750J	04 - 06	200-L08...	200SL08...	200-R17...	200SR17...	99,95
Z 750	ZR750L	07 -	200-L17...	200SL17...	200-R17...	200SR17...	99,95
Z 750 ABS	ZR750L	07 -	200-L17...	200SL17...	200-R20...	200SR20...	99,95
Z 750R ABS	ZR750N	11 -	200-L17...	200SL17...	200-R21...	200SR21...	99,95
Zephyr 750	ZR750C	91 - 99	200-L08...	200SL08...	200-R17...	200SR17...	99,95
ZR-7 /S	ZR750F	99 - 03	200-L08...	200SL08...	200-R17...	200SR17...	99,95
ZX-7R /RR Ninja	ZX750N	96 - 02	200-L24...	200SL24...	200-R17...	200SR17...	99,95
ZXR 750 /R	ZX750H/J/L	89 - 94	200-L24...	200SL24...	200-R17...	200SR17...	99,95
W 800	EJ800A	11 -	200-L08...	200SL08...	200-R17...	200SR17...	99,95
Z 800 ABS	ZR800A	13 -	200-L17...	200SL17...	200-R20...	200SR20...	99,95
GPZ 900R	ZX900A	84 - 93	200-L24...	200SL24...	200-R17...	200SR17...	99,95
ZX-9R Ninja	ZX900B	94 - 97	200-L24...	200SL24...	200-R17...	200SR17...	99,95
ZX-9R Ninja	ZX900C	98 - 99	200-L08...	200SL08...	200-R17...	200SR17...	99,95
ZX-9R Ninja	ZX900E	00 - 03	200-L17...	200SL17...	200-R17...	200SR17...	99,95
KLV 1000	KLV1000A	04 - 05	200-L22...	200SL22...	200-R17...	200SR17...	99,95
Versys 1000	LZT00A	12 - 14	200-L17...	200SL17...	200-R17...	200SR17...	99,95
Versys 1000	LZT00R	15 -	200-L08...	200SL08...	200-R20...	200SR20...	99,95
Z 1000	ZRT00A	03 - 06	200-L17...	200SL17...	200-R17...	200SR17...	99,95
Z 1000 (ABS)	ZRT00B/D/F	07 -	200-L17...	200SL17...	200-R21...	200SR21...	99,95
Z 1000/ SX /Tourer ABS	ZXT00G/L	11 - 16	200-L17...	200SL17...	200-R21...	200SR21...	99,95
Z 1000SX	ZXT00W	17 -	200-L08...	200SL08...	200-R21...	200SR21...	99,95
ZX-10	ZXT00B	88 - 90	200-L24...	200SL24...	200-R17...	200SR17...	99,95
ZX-10 R ABS	ZXT00S	16 -	200-L17...	200SL17...	200-R23R...	200SR23R...	99,95
ZX-10 R Ninja	ZXT00C	04 - 05	200-L17...	200SL17...	200-R17...	200SR17...	99,95
ZX-10 R Ninja	ZXT00D/E/F/J	06 - / -15	200-L17...	200SL17...	200-R21...	200SR21...	99,95
GPZ 1100 (ABS)	ZXT10E	95 - 98	200-L24...	200SL24...	200-R17...	200SR17...	99,95
Zephyr 1100	ZRT10A	92 - 98	200-L24...	200SL24...	200-R17...	200SR17...	99,95
ZRX 1100	ZRT10C	97 - 00	200-L24...	200SL24...	200-R17...	200SR17...	99,95
ZZR 1100	ZXT10C/D	90 - 01	200-L24...	200SL24...	200-R17...	200SR17...	99,95
ZRX 1200 /R /S	ZRT20A	01 - 07	200-L24...	200SL24...	200-R17...	200SR17...	99,95
ZX-12R Ninja	ZXT20A	00 - 06	200-L17...	200SL17...	200-R17...	200SR17...	99,95
ZZR 1200	ZXT20C	02 - 05	200-L24...	200SL24...	200-R17...	200SR17...	99,95
1400 GTR (ABS) (CBS)	ZGT40A/C	08 -	200-L23R...	200SL23R...	200-R21...	200SR21...	99,95
ZZR 1400 (ABS)	ZXT40A/C/E	06 - 15	200-L23R...	200SL23R...	200-R21...	200SR21...	99,95
KTM							
125 /200 /390 Duke	IS Duke C3	13-	200-L48R...	200SL48R...	200-R48R...	200SR48R...	99,95
690 Duke	DUKE	08 - 11	200-L32R...	200SL32R...	200-R23R...	200SR23R...	99,95
690 Duke	A3	12 - 13	-	-	200-R12...	200SR12...	99,95
690 Duke	A3	14 -	200-L49R...	200SL49R...	200-R12...	200SR12...	99,95
990 SMT	LC8SM	09 -	-	-	200-R23R...	200SR23R...	99,95
990 Super Duke	LC8EFI	05 -	200-L32R...	200SL32R...	200-R23R...	200SR23R...	99,95
1190 RC 8	RC8	08 -	200-L32R...	200SL32R...	200-R23R...	200SR23R...	99,95
1290 Super Duke /R	V3	14 -	200-L32R...	200SL32R...	200-R23R...	200SR23R...	99,95

NEW

NEW

_ BRAKE SYSTEM LEVER

model	type	year	lever				EUR	p/pc
			clutch lever		brake lever			
			long	short	long	short		
			colours: silver: SI; anthracite: AN; black: SW; gold: GO (please complete item no)					
			The adjusters are available in different colours, see page 60 please					
/... = also for this model								
(ABS) = also for models with ABS								
ABS = for models with ABS only								
Moto Guzzi								
750 Nevada	LM	03 -	-	-	200-R22...	200SR22...	99,95	
V9 Bobber	LHA	16-	-	-	200-R22...	-	99,95	
V11	KR/KS/KT	99 - 05	200-L12...	200SL12...	200-R12...	200SR12...	99,95	
1200 Sport	LP	07 -	200-L13...	200SL13...	200-R22...	200SR22...	99,95	
Moto Morini								
Corsaro 1200	01	06 -	200-L13...	200SL13...	200-R22...	200SR22...	99,95	
MV Agusta								
Brutale 800 ABS	B3	14 -	200-L53...	200SL53...	200-R50...	200SR50...	99,95	
F3 800 ABS	F3	14 -	200-L53...	200SL53...	200-R54R...	-	99,95	
F3 675	F3	12 -	200-L53...	200SL53...	200-R18R...	200SR18R...	99,95	
MZ								
MZ 1000 S	MZ1000	04 - 08	200-L22...	200SL22...	200-R17...	200SR17...	99,95	
MZ 1000 SF /SFs	MZ1000	05 - 08	200-L24...	200SL24...	200-R18R...	200SR18R...	99,95	
Suzuki								
GS 500 E	GM 51 B	89 - 00	200-L03...	200SL03...	200-R17...	200SR17...	99,95	
GS 500 /F /H	BK/WVBK	01 - 06	200-L03...	200SL03...	200-R17...	200SR17...	99,95	
GSF 600 /S Bandit	GN77B/WVA8	95 - 04	200-L03...	200SL03...	200-R17...	200SR17...	99,95	
GSR 600	WVB9	06 - 10	200-L18...	200SL18...	200-R17...	200SR17...	99,95	
GSX 600F	GN72B/AJ	88 - 01	200-L04...	200SL04...	-	-	99,95	
GSX-R 600	AD/WVBG	97 - 03	200-L18...	200SL18...	200-R17...	200SR17...	99,95	
GSX-R 600	WVB2	04 - 05	200-L18...	200SL18...	200-R18R...	200SR18R...	99,95	
GSX-R 600	WVCE/CV/C3	06 -	200-L19...	200SL19...	200-R18R...	200SR18R...	99,95	
RF 600R	GN76B	93 - 96	200-L04...	200SL04...	200-R17...	200SR17...	99,95	
DL 650 V-Strom (ABS)	WVB1	04 - 09	200-L04...	200SL04...	200-R17...	200SR17...	99,95	
DL 650 V-Strom (ABS)	WVB1	10 - 11	200-L29...	200SL29...	200-R17...	200SR17...	99,95	
DL 650A V-Strom ABS	C7	12 -	200-L18...	200SL18...	200-R17...	200SR17...	99,95	
GSF 650 /A /S /SA Bandit (ABS)	WVB5	05 - 06	-	-	200-R17...	200SR17...	99,95	
GSF 650A /SA Bandit ABS	WVCJ/CZ	07 -	200-L22...	200SL22...	200-R17...	200SR17...	99,95	
GSX 650 F (ABS)	WVCJ	08 -	200-L22...	200SL22...	200-R17...	200SR17...	99,95	
SFV 650 Gladius (ABS)	WVCX	09 -	200-L18...	200SL18...	200-R17...	200SR17...	99,95	
SV 650 /S (ABS)	AV/WVBY	99 - 08	200-L04...	200SL04...	200-R17...	200SR17...	99,95	
SV 650 ABS	CX	16-	200-L18...	200SL18...	200-R17...	200SR17...	99,95	
GSR 750	C5	11 -	200-L18...	200SL18...	200-R17...	200SR17...	99,95	
GSX 750	AE	98 - 01	200-L03...	200SL03...	200-R17...	200SR17...	99,95	
GSX 750 F	GR78A/AK/WVAK	89 - 06	200-L04...	200SL04...	200-R17...	200SR17...	99,95	
GSX-R 750	GR77B/GR7AB	88 - 91	200-L04...	200SL04...	200-R17...	200SR17...	99,95	
GSX-R 750W /SP	GR7BB	92 - 95	200-L04...	200SL04...	200-R17...	200SR17...	99,95	
GSX-R 750	GR7DB/WVBD	96 - 03	200-L18...	200SL18...	200-R17...	200SR17...	99,95	
GSX-R 750	WVB3	04 - 05	200-L18...	200SL18...	200-R18R...	200SR18R...	99,95	
GSX-R 750	WVCF/CW/C4	06 -	200-L19...	200SL19...	200-R18R...	200SR18R...	99,95	
RF 900R	GT73B	94 - 97	200-L02R...	200SL02R...	200-R17...	200SR17...	99,95	
DL 1000 V-Strom	WVBS/DD	02 - 07 /14-	200-L22...	200SL22...	200-R17...	200SR17...	99,95	
GSX-R 1000	WVBL/WVBZ	01 - 04	200-L18...	200SL18...	200-R17...	200SR17...	99,95	
GSX-R 1000	WVB6	05 - 06	200-L19...	200SL19...	200-R18R...	200SR18R...	99,95	
GSX-R 1000	WVCL	07 - 08	200-L22R...	200SL22R...	200-R18R...	200SR18R...	99,95	
GSX-R 1000	WVCY	09 -	200-L19...	200SL19...	200-R18R...	200SR18R...	99,95	
GSX-S 1000 /F ABS	DG	15 -	200-L19...	200SL19...	200-R18R...	200SR18R...	99,95	
SV 1000 /S	WVBX	03 - 05	200-L22...	200SL22...	200-R17...	200SR17...	99,95	
TL 1000 R	AM	98 - 99	200-L22...	200SL22...	200-R17...	200SR17...	99,95	
TL 1000 S	AG	97 - 00	200-L18...	200SL18...	200-R17...	200SR17...	99,95	
GSX-R 1100 /W	GV73C/GU75C	89 - 96	200-L02R...	200SL02R...	200-R17...	200SR17...	99,95	
GSF 1200 /S Bandit (ABS)	GV75A	96 - 00	200-L02R...	200SL02R...	200-R17...	200SR17...	99,95	
GSF 1200 /S Bandit (ABS)	WVA9/WVBC	01 - 06	200-L22...	200SL22...	200-R17...	200SR17...	99,95	
GSX 1200 Inazuma	A3	99 - 00	200-L02R...	200SL02R...	200-R17...	200SR17...	99,95	
GSX 1250 /S Bandit /FA (ABS)	WVCH	07 -	200-L22...	200SL22...	200-R17...	200SR17...	99,95	
GSX 1300 BK B-King (ABS)	WVCR	08 - 10	-	-	200-R18R...	200SR18R...	99,95	
GSX 1300 R Hayabusa /II	WVA1/WVCK	99 - 12	200-L22...	200SL22...	200-R17...	200SR17...	99,95	
GSX 1400	WVBN	02 - 06	200-L22...	200SL22...	200-R17...	200SR17...	99,95	
Triumph								
Daytona 600	806LW	04	200-L26...	200SL26...	200-R17...	200SR17...	99,95	
Speed Four	806LB	02 - 05	200-L26...	200SL26...	200-R17...	200SR17...	99,95	
TT 600	806AD	00 - 03	200-L07...	200SL07...	200-R17...	200SR17...	99,95	
Daytona 650	865LX	05	200-L26...	200SL26...	200-R17...	200SR17...	99,95	
Daytona 675	D67LC	06 -	200-L26...	200SL26...	200-R18R...	200SR18R...	99,95	
Daytona 675 R (ABS)	D67LC/H67	11 -	200-L26...	200SL26...	200-R23R...	200SR23R...	99,95	
Street Twin / Tiger 800 (ABS)	DP01/ A082	16 - /15-	200-L54...	200SL54...	200-R51...	200SR51...	99,95	
Street Triple	D67LD	08 -	200-L26...	200SL26...	200-R17...	200SR17...	99,95	
Street Triple R	D67LD/LR	09 -	200-L26...	200SL26...	200-R18R...	200SR18R...	99,95	
America	908M	02 - 06	200-L07...	200SL07...	200-R17...	200SR17...	99,95	
Bonneville	908MD	02 - 06	200-L07...	200SL07...	200-R17...	200SR17...	99,95	

model	type	year	lever		brake lever		EUR p/pc
			clutch lever	brake lever	long	short	
<i>colours: silver: SI; anthracite: AN; black: SW; gold: GO (please complete item no)</i> <i>The adjusters are available in different colours, see page 60 please</i>							
<i>/... = also for this model</i> <i>(ABS) = also for models with ABS</i> <i>ABS = for models with ABS only</i>			long	short	long	short	
Triumph							
Tiger 800 (ABS) Not with hand protectors!	A08	11 - 14	200-L26...	200SL26...	200-R17...	200SR17...	99,95
Tiger 800 (ABS) Not with hand protectors!	A082	15-	200-L54...	200SL54...	200-R51...	200SR51...	99,95
America	908MK/908MK2	07 -	200-L26...	200SL26...	200-R17...	200SR17...	99,95
Bonneville /T100	986MF	05 - 15	200-L26...	200SL26...	200-R17...	200SR17...	99,95
Bonneville T100	DB01	17-	200-L54...	200SL54...	200-R51...	200SR51...	99,95
Bonneville T120	DU01/1/1	16 -	200-L54...	200SL54...	200-R51...	200SR51...	99,95
Street Cup	DZ01	17-	200-L54...	200SL54...	200-R17...	200SR17...	99,95
Scrambler	986MG/2	06 - 15	200-L26...	200SL26...	200-R17...	200SR17...	99,95
Speed Master	908ML	03 - 07	200-L07...	200SL07...	200-R17...	200SR17...	99,95
Speed Master	986ML2	08 - 15	200-L26...	200SL26...	200-R17...	200SR17...	99,95
Thruxton 900	986ME/2	05 - 15	200-L26...	200SL26...	200-R17...	200SR17...	99,95
Thruxton R	DE01/1/1	16 -	200-L54...	200SL54...	200-R23R...	200SR23R...	99,95
Thruxton	DE01/1/2	16 -	200-L54...	200SL54...	200-R51...	200SR51...*	99,95
Thunderbird	T309RT/309RT	95 - 03	200-L24...	200SL24...	200-R17...	200SR17...	99,95
Thunderbird Sport	T309RT/309RD	98 - 04	200-L24...	200SL24...	200-R17...	200SR17...	99,95
Daytona T595 /955i / Century Edition	T595/595N	97 - 04*	200-L07...*	200SL07...*	200-R17...	200SR17...	99,95
Speed Triple /T509	T509/595RPT	97 - 01	200-L07...	200SL07...	200-R17...	200SR17...	99,95
Speed Triple	595N	02 - 04*	200-L26...*	200SL26...*	200-R17...	200SR17...	99,95
Sprint RS /ST	T695/695AC/AB	99 - 04	200-L07...	200SL07...	200-R17...	200SR17...	99,95
Tiger 900 /955	709/709EN	99 - 14	200-L26...	200SL26...	200-R17...	200SR17...	99,95
Speed Triple 1050	515NJ	05 - 07	200-L26...	200SL26...	200-R17...	200SR17...	99,95
Speed Triple 1050	515NJ	08 - 11	200-L26...	200SL26...	200-R18R...	200SR18R...	99,95
Speed Triple 1050 (ABS) /R	515NV	11 - 15	200-L26...	200SL26...	200-R23R...	200SR23R...	99,95
Speed Triple 1050 (ABS) /R		16 -	200-L54...	200SL54...	200-R23R...	200SR23R...	99,95
Sprint ST (ABS)	215NA	05 -	200-L26...	200SL26...	200-R17...	200SR17...	99,95
Tiger 1050 (ABS)	115NG	07 -	200-L26...	200SL26...	200-R17...	200SR17...	99,95
Tiger Sport 1050 ABS		14 -	200-L54...	200SL54...	200-R17...	200SR17...	99,95
Tiger 1200 Explorer ABS (XC)	V13VG	12 -	200-L24...	200SL24...	200-R51...	200SR51...	99,95
Thunderbird Storm ABS	B16BA	11-	200-L40...	200SL40...	200-R40R...	200SR40R...	99,95
Rocket III /Classic	C 23XB	05 -	-	-	200-R17...	200SR17...	99,95
* changing in current Model year at Lever Version L26, please check VIN and ask for the right version ** available lever colours: black or silver							
Victory (available lever colours: black or silver)							
Hammer / S / Eight Ball	H/J	09 -	200-L42X...*	-	200-R42X...*	-	129,95
High Ball	all	all	200-L42X...*	-	200-R42X...*	-	129,95
Kingpin/Kingpin Eight Ball	V/K	11-	200-L42X...*	-	200-R42X...*	-	129,95
Ness Jackpot	H/J	09-	200-L42X...*	-	200-R42X...*	-	129,95
Vegas / Vegas Eight Ball	V/K	09 -	200-L42X...*	-	200-R42X...*	-	129,95
Vision / Ness Vision	Vision	10 -	200-L42X...*	-	200-R42X...*	-	129,95
Cruiser / Cross Country	V3	all	200-L42X...*	-	200-R42X...*	-	129,95
* available lever colours: black or silver							
Voxan							
Cafe Racer /Roadster	V2	02 -	200-L13...	200SL13...	200-R13...	200SR13...	99,95
Yamaha							
YZF-R 125	RE06	08 -	200-L29...	200SL29...	-	-	99,95
SR 400	RH05	14 -	200-L45R...	200SL45R...	200-R45...	200R45...	99,95
XJR 400	4HM	90 - 07	200-L29...	200SL29...	200-R17...	200R17...	99,95
SR 500	2J4	78 - 83	200-L45R...	200SL45R...	200-R45R...	200SR45R...	99,95
FZ 6 Fazer /S /S2 (ABS)	RJ07 /14	04 -	200-L20...	200SL20...	200-R22...	200SR22...	99,95
FZR 600 Genesis	all	89 - 93	200-L06...	200SL06...	200-R10...	200SR10...	99,95
FZR 600 R Genesis	4JH /4MH	94 - 95	200-L06...	200SL06...	200-R17...	200SR17...	99,95
FZS 600 Fazer	RJ02	98 - 03	200-L29...	200SL29...	200-R17...	200SR17...	99,95
SRX 600	all	86 - 89	-	-	200-R10...	200SR10...	99,95
XJ 600 N /S /Diversion	4BR /4LX /RJ01	92 - 03	200-L29...	200SL29...	-	-	99,95
XJ 6 /Diversion /F (ABS)	RJ19	09 - 11	200-L20...	200SL20...	200-R22...	200SR22...	99,95
XJ 6 /Diversion /F (ABS)	RJ22	13 -	200-L20...	200SL20...	200-R22...	200SR22...	99,95
YZF 600R Thundercat	4TV /4WD	96 - 02	200-L06...	200SL06...	200-R17...	200SR17...	99,95
YZF-R 6	RJ03 /05 /09	99 - 04	200-L20...	200SL20...	200-R17...	200SR17...	99,95
YZF-R 6 /S	RJ095 /11 /15	05 -	200-L20...	200SL20...	200-R35R...	200SR35R...	99,95
XS 650	447 / 3L1	77 - 83	200-L45R...	200SL45R...	200-R45R...	200SR45R...	99,95
MT-03	RM02	06 -	-	-	200-R22...	200SR22...	99,95
SZR 660	4SV	95 - 98	200-L06...	200SL06...	200-R12...	200SR12...	99,95
MT-07	RM041	14 -	200-L20...	200SL20...	200-R22...	200SR22...	99,95
XSR 700 ABS /900 ABS	RM11/ RN431	15 -/16-	200-L20...	200SL20...	200-R22...	200SR22...	99,95
FZ 750 /Genesis	all	85 - 94	200-L05...	200SL05...	200-R10...	200SR10...	99,95
FZX 750	2JE	87 - 89	200-L05...	200SL05...	200-R10...	200SR10...	99,95
YZF 750 R /SP	all	93 - 98	200-L24...	200SL24...	200-R17...	200SR17...	99,95
FZ 8 /Fazer 8 (ABS)	RN25	10 -	200-L20...	200SL20...	200-R22...	200SR22...	99,95
MT-09 (ABS) / MT 03 Tracer	RN29 /RN29F	14 -	200-L20...	200SL20...	200-R22...	200SR22...	99,95
TRX 850	4UN	96 - 00	200-L06...	200SL06...	200-R17...	200SR17...	99,95
TDM 900 (ABS)	RN08 /11 /18	02 -	200-L29...	200SL29...	200-R17...	200SR17...	99,95

NEW

NEW

NEW

NEW

_ BRAKE SYSTEM LEVER

model	type	year	lever				EUR	p/pc
			clutch lever		brake lever			
			long	short	long	short		
/... = also for this model (ABS) = also for models with ABS ABS = for models with ABS only			colours: silver: <i>SI</i> ; anthracite: <i>AN</i> ; black: <i>SW</i> ; gold: <i>GO</i> (please complete item no) The adjusters are available in different colours, see page 60 please					
Yamaha								
XJ 900 Diversion	4KM	95 - 03	200-L29...	200SL29...	-	-	99,95	
XV 950 ABS	VN03	14 -	200-L43...	200SL43...	200-R43R...	200SR43R...	99,95	
FZ 1 /Fazer (ABS)	RN16	06 -	200-L20...	200SL20...	200-R22...	200SR22...	99,95	
FZR 1000 Genesis	2LA	87 - 88	200-L05...	200SL05...	200-R10...	200SR10...	99,95	
FZR 1000 Genesis EXUP	3LE	89 - 91	200-L24...	200SL24...	-	-	99,95	
FZR 1000 Genesis EXUP	3LE	92 - 95	200-L24...	200SL24...	200-R17...	200SR17...	99,95	
FZS 1000 Fazer	RN06 /14	01 - 05	200-L20...	200SL20...	200-R17...	200SR17...	99,95	
YZF 1000 Thunderace	4VD /4SV	96 - 01	200-L24...	200SL24...	200-R17...	200SR17...	99,95	
YZF-R 1	RN 01	98	200-L18...	200SL18...	200-R20...	200SR20...	99,95	
YZF-R 1	RN 01 /04	99 - 01	200-L20...	200SL20...	200-R20...	200SR20...	99,95	
YZF-R 1	RN 09	02 - 03	200-L20...	200SL20...	200-R17...	200SR17...	99,95	
YZF-R 1 /SP	RN 12 /19	04 - 08	200-L20...	200SL20...	200-R35R...	200SR35R...	99,95	
YZF-R 1	RN22	09 - 14	200-L20...	200SL20...	200-R19R...	200SR19R...	99,95	
YZF-R 1M	RN32	15 -	200-L20...	200SL20...	200-R49R...	200SR49R...	99,95	
MT-10	RN451	16 -	200-L58R... in prep.	200SL58R... in prep.	200-R22...	200SR22...	99,95	
BT 1100 Bulldog (NSR 1100)	RP05	02 - 04	200-L29...	200SL29...	200-R17...	200SR17...	99,95	
BT 1100 Bulldog (NSR 1100)	RP05	05 - 07	200-L29...	200SL29...	200-R22...	200SR22...	99,95	
FJ 1100	47E	85 - 86	-	-	200-R10...	200SR10...	99,95	
FJ 1200 ABS	all	87 - 97	200-L05...	200SL05...	-	-	99,95	
FJ 1200 without ABS	all	87 - 97	200-L05...	200SL05...	200-R10...	200SR10...	99,95	
VMX 1200	all	- 04	-	-	200-R10...	200SR10...	99,95	
XJR 1200 /SP	4PU	96 - 99	200-L24...	200SL24...	200-R17...	200SR17...	99,95	
XT 1200Z Super Ténéré	DP01	12 -	-	-	200-R22...	200SR22...	99,95	
XT 1200Z	DP15	13 -	200-L24...	200-L24...	200-R22...	200SR22...	99,95	
FJR 1300	RP 04	01 - 02	200-L24...	200SL24...	200-R17...	200SR17...	99,95	
FJR 1300 /A /AS	RP08/11/13	03 -	200-L24...	200SL24...	200-R22...	200SR22...	99,95	
XJR 1300	RP02/06	99 - 03	200-L24...	200SL24...	200-R17...	200SR17...	99,95	
XJR 1300	RP10/19	04 -	200-L24...	200SL24...	200-R22...	200SR22...	99,95	
MT-01 /S	RP12/18	05 -	200-L24...	200SL24...	200-R35R...	200SR35R...	99,95	
V-Max 1700	RP21	09 -	200-L24...	200SL24...	200-R35R...	200SR35R...	99,95	



SPECIAL HARLEY LEVER

Specially shaped levers had to be developed for the handlebar fittings of the Harley-Davidson models, these bring the access very close to the armatures.

This particular shape is used for many Harley and Victory models. This variant is only available with silver or black lever.

NEW

**ADJUSTABLE LEVERS
FOR SCOOTER**

In many countries the scooter trend is undefeated and some scooter models represent the position of the best-selling two-wheeler. No question that LSL also adopted these vehicles. From this year on we also offer adjustable lever sets for the current scooter models and the MP3.

The scooter levers are always packed as a pair and only available in black or silver with black adjusters.



Brand New ! Available from April 2017



model	year	lever pair		EUR / pair
		black lever pair: SW Brake and Clutch Lever	silver lever pair: SI Brake and Clutch Lever	
Vespa				
GT 125 / 200	2003-2006	203V002SW	203V002SI	179,90
GTL 125 / 200	2003-2006	203V002SW	203V002SI	179,90
GTL 125 / 200	2003-2006	203V002SW	203V002SI	179,90
GTS 125 / 250 / 300	2005 -	203V002SW	203V002SI	179,90
LX 125	2005 -	203V002SW	203V002SI	179,90
S / Sprint 125 / 150	2005 -	203V002SW	203V002SI	179,90
Primavera 125 / 150	2013 -	203V002SW	203V002SI	179,90
Piaggio				
MP3 125 / 250 / 300 / 500	2006 - 2013	203P003SW	203P003SI	179,90
MP3 Urban	2009 -	203P003SW	203P003SI	179,90
Beverly 125 - 500	2002 -	203P003SW	203P003SI	179,90
X8 125 / 200 / 250 / 400	2006 -	203P003SW	203P003SI	179,90
X9 125 / 180 / 250 / 500	2001 -	203P003SW	203P003SI	179,90
X Evo 400	2009 -	203P003SW	203P003SI	179,90
Medley 125 / 150	2016 -	203V002SW	203V002SI	179,90
MP3 300 / 500	2014 -	203P004SW	203P004SI	179,90

NEW

NEW

_ BRAKE SYSTEM **BRAKE FLUID RESERVOIR**

LSL BRAKE BOX AND LSL CLUTCH BOX

A long overdue replacement for those ugly plastic brake fluid reservoirs.

Several aspects must be adhered in order to meet the requirements of a secure reservoir on the brake pump needs. The minimum content amount must be guaranteed, all components involved must be resistant to the corrosive fluid. Less weight is desired and after all it supposed to look great.

The LSL result is the Brake Box - CNC machined aluminum in shiny finish.

The Brake Box is available in two sizes. The big box holds 38 ml and is ABE approved for use on many models. The smaller Clutch Box holds 19 ml and is suitable for clutch and rear brake system. Mounting brackets are available for both versions.



244BB02SW

product	volume	colour	item no	EUR
brake fluid reservoir				
Brake Box	38 ml	black	244BB02SW	79,95
Kawasaki, Suzuki, Triumph, Yamaha – Halter enthalten				



244BT02SW

product	volume	colour	item no	EUR
clutch fluid reservoir				
Clutch Box	19 ml	black	244BT02SW	69,95



All LSL liquid reservoirs may only be filled with brake fluid. No oil!

LSL BRAKE BOX FÜR BMW-MODELLE

LSL has developed a brake fluid reservoir to specifically match the brake pump on current BMW models. The bottom of this brake fluid box is designed to replicate the OEM part which makes a replacement much easier.

If the OEM box came equipped with a foam cylinder, the LSL replacement product will be shipped with one as well.

The LSL brake fluid box can only be mounted on BMW motorcycles with 2nd Generation Integrated Anti-Lock Brakes that are equipped with a round plastic reservoir bolted directly to the brake pump. Some models come with two different brake pumps.

We'll be happy to find out which one fits your motorcycle, all we need is the chassis number.

BRAKE BOX 244BB41...

The old version of the pump is equipped with a brake bleeder and the handlebar clamp is bolted on with two M5 screws. Usually, the box comes with a yellow foam insert.

LSL CLUTCH COVER FOR BMW-MODELS

Clutch-Cover only for the BMW clutch fluid reservoir.

for BMW	colour	item no	EUR
clutch fluid reservoir cover for BMW models			
Clutch Cover	silver	246BB41SI	29,95
Clutch Cover	black	246BB41SW	29,95

UNIVERSAL RESERVOIR BRACKETS



option 243-H82: bracket to mount on Honda and KTM models.

option 243-BT1: bracket to mount clutch fluid reservoir sidewise and mounting rear brake system

product	material	item no	EUR
Reservoir Brackets			
Honda, KTM	stainless steel	243-H82	6,95
sideways bracket	stainless steel	243-BT1	6,95

The Brake Box CANNOT be used as a clutch fluid reservoir!



for BMW	volume	colour	item no	EUR
brake fluid reservoir for BMW models				
Brake Box BMW	36 ml	black	244BB41SW	79,95
Brake Box BMW	36 ml	silver	244BB41SI	79,95
foamed plastic insertion BMW Brake Box 244BB41...			244-SE01	3,95
Brake Box BMW	36 ml	black	244BB44SW	79,95
Brake Box BMW	36 ml	silver	244BB44SI	79,95

BRAKE BOX 244BB44...

The new version of the pump is NOT equipped with a brake bleeder and the handlebar clamp is bolted on with two M6 screws. The box does not come with a yellow foam insert.



_ BRAKE SYSTEM **STAINLESS STEEL BRAKE LINES**



! The mounting of these parts is demanding and should be done only by a trained mechanic.

STAINLESS STEEL - **BRAKE LINES**

The first step in improving the brake system. In Krefeld we manufacture brake hoses of components by the Swiss manufacturer Speed Brakes, these meet the special quality requirements.

The brake hose fittings are made of a special aluminum alloy which has special deformation features. The homogeneous structure is maintained while making the connection bends, brittle fracture is permanently prevented.

The brake hose quality with PTFE (Teflon) for the inner core and plastic coating is mandatory. The PVC jacket protects adjacent surfaces from scratches. The plastic cover also prevents the entry of corrosive brake dust, and thus a reaming of steel braid.

The jacket is available in clear, smoke gray and black, other colors on request. Brake hoses are delivered in the original length and come with type approval. Custom made cables receive a TÜV certificate.

LSL PERFORMANCE

Performance Stainless steel brake lines

- _ Steel braided brake hose with a PTFE inner pipe, plastic-coated
- _ Fittings polished alu, anodised coloured
- _ Kit fully assembled or according to sample
- _ Cables available in various colours







model specific brake line kits	type	EUR
kits front		
1 - piece	F	59,95
1 - piece with cross support	X	85,95
2 - piece	G	99,95
2 - piece cross over	H	99,95
2 - piece with hollow screw	J	99,95
3 - piece	K	129,95
3 - piece, pressed divider	L	129,95
3 - piece with divider	O	149,95
4 - piece	N	159,95
5 - piece	M	189,95
kits rear		
1 - piece	R	49,95
clutch		
1 - piece	C	59,95

colour of fittings	surface	order info
anthracite		anodised standard
black		anodised item no + SW
silver		anodised item no + SI
blue		anodised item no + BL

COLOUR

colour of brake line cover	cover	order info
rauchgrau		Kunststoff Standard
black		Kunststoff item no + SW

COLOUR

colour of alu-banjo bolts	surface	order info
anthracite		anodised item no + AN
black		anodised item no + SW
silver		anodised item no + SI
gold		anodised item no + GO
red		anodised item no + RT
blue		anodised item no + BL

COLOUR

Specially for you produced brake linings we can not take back !

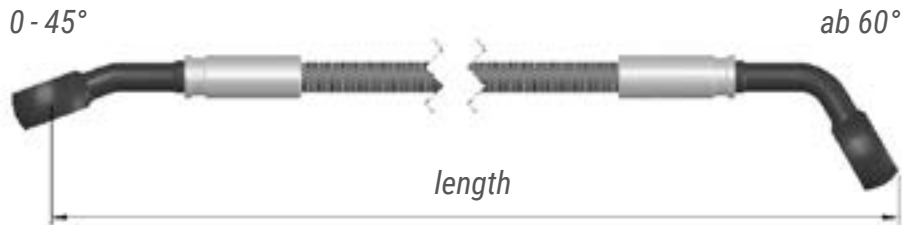

Order info:

Please always order model specific hoses by specifying the type and model year of your motorcycle.

We definitely recommend a consultation with our sales staff by email or phone, as an individual conversion to steel brake lines is an intervention in the brake system.

universal	item no	EUR
length		
< 30 cm	220-030	42,95
< 40 cm	220-040	45,95
every 10 cm more	220- + length	+ 3,00
chromed fittings, p/line		+ 2,50

ALUMINUM **BANJO BOLTS**

In addition to our brake hose kits LSL offers colored anodized aluminum banjo bolts in single or dual function (colour of alu-banjo bolts, left side).



aluminum banjo bolts	item no ... colour code	EUR
single		
M10 x 1.00	220-301...	4,95
M10 x 1.25	220-302...	4,95
double		
M10 x 1.00	220-311...	5,95
M10 x 1.25	220-312...	5,95

BRAKE LIGHT **SWITCH**

Banjo bolt with hydraulically operated brake light switch, optionally in M10 x 1.00 or M10 x 1.25 and also as a double banjo bolt.



brake light switch	item no	EUR
single		
M10 x 1.00	220-301ST	18,95
M10 x 1.25	220-302ST	18,95
3/8" UNF	220-303ST	19,95
double		
M10 x 1.00	220-311ST	20,95
M10 x 1.25	220-312ST	20,95

SUPERBIKE KITS



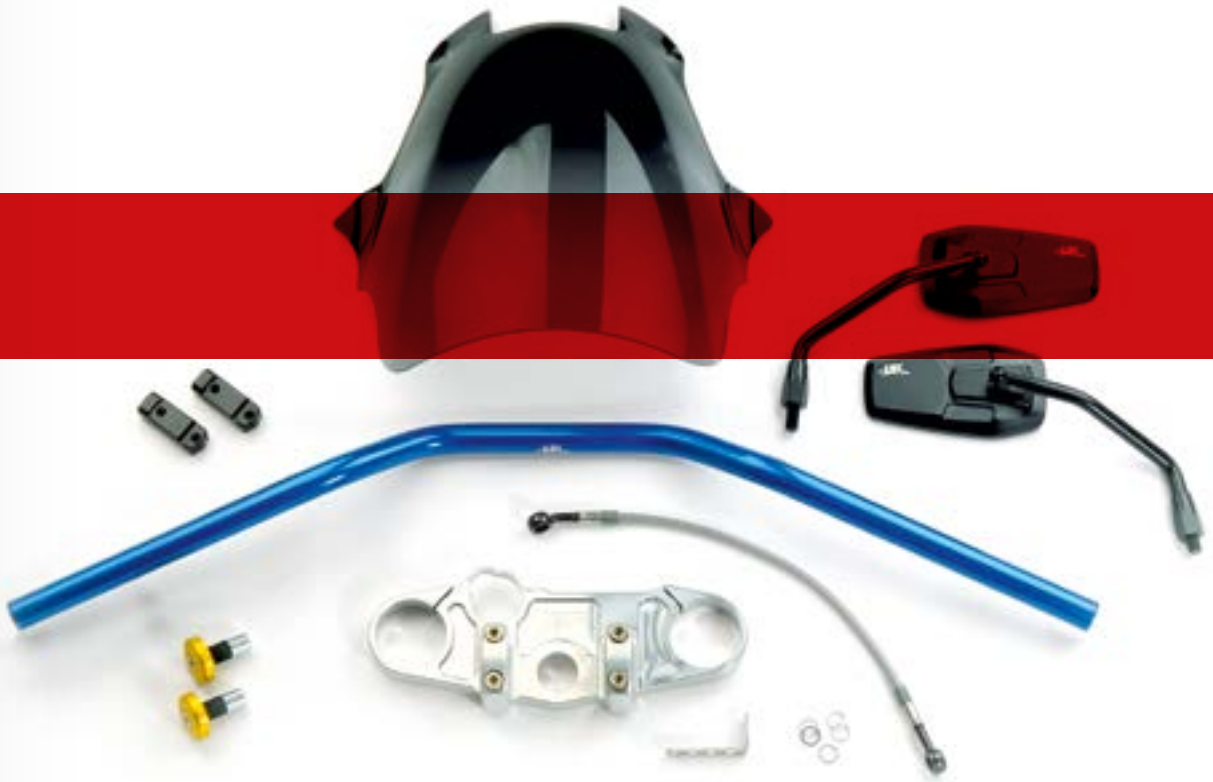

SUPERBIKE - CONVERSION KITS

Even the first comparison test in 1993 by the motorcycle magazin MOTORRAD found out that a better turning and braking is achieved with a comfortable superbike handlebar. On the following pages you will find all the details for the professional upgrading of your steering system.

LSL found the best possible and individual solution for each model. The handlebar support varies from a simple adapter to elaborately crafted complete top yokes. Handlebars in sporty slim versions up to high handlebars for touring are possible. No details are left open for the mechanic. Whether

it is the bracket of the brake fluid reservoir or a longer cable is necessary, the LSL solution offers functionality and completeness.

Depending on the vehicle type, different construction principles are chosen to implement the conversion to a superbike handlebar. Depending on the model, longer brake hoses, new brake fluid reservoir bracket or panel brackets are required. The matching handlebars are not included in the kit, they need to be ordered separately because of the possible materials and colors.

LSL PERFORMANCE

Performance Superbike kits

- _ Top yokes and adapters made of high-class milled aluminum, anodised
- _ Complete model specific product, including all mounting parts
- _ Accurate fitting instructions, German TÜV certification (required for German license)

Important Info

The LSL Superbike handlebar kits are designed so that they can be mounted in a reasonable amount of time and normal tool equipment. If you are not a trained motorcycle mechanic, you should ask us for advice and contact a dealer nearby.

VARIANT G COMPLETE TOP YOKE



VARIANT A ONE PIECE ADAPTER PLATE



VARIANT S TWO PIECE ADAPTER PLATE



ORDER INSTRUCTIONS SUPERBIKE KITS

Due to the design it is often unavoidable that the standard fairing needs cutting or a sector needs to be cut out. Please pay attention to the details in the „cut fairing“.

The appropriate handlebars are not included in the kit, they need to be ordered separately because of the possible selection of materials and colors.

The mounting of these parts is demanding and should be done only by a trained mechanic.



Superbike kit (w/o handlebar)



handlebar



extension, mirror adapter

model	type	year	version (page 73)	brake line/-s	clutch line/-cable	throttle cable/-s	fairing support	windscreen	cut fairing	item no	EUR	X-Bar clamping 22mm clamping	recommended handlebar - please order in addition	handlebar extension	mirror bracket required - please order in addition left/right
			included	!	!	!	!	!	!	St: silver SW: black	Ø	! please order these parts in addition			
Aprilia															
RSV Mille	ME	01-03	G	•	•					120A009	SI 439,00	•	Superbike	-	-
Falco SL 1000	PA	00-04	G	•	•					120A010	SI 439,00	•	Superbike	-	-
BMW															
F800S	E8ST	06-10	G							120B032	SI 239,00	•	Superbike	-	-
S 1000RR ABS	K10	10-11	G	•						120B040ABS	SI 369,00	•	Superbike flat	-	-
S 1000RR ABS	K10	10-11	G	•						120B040ABSSW	369,00	•	Superbike flat	-	-
S 1000RR ABS	K10	12-14	G	•						120B043ABS	SI 369,00	•	Superbike flat	-	-
S 1000RR ABS	K10	12-14	G	•						120B043ABSSW	369,00	•	Superbike flat	-	-
R 1100S ABS	R2S	00-03	S	•						120B025ABS	SI 199,00	•	BMW	-	-
R 1100S	R2S	00-03	S	•						120B025	SI 249,00	•	BMW	-	-
R 1100S	R2S/R11S	01-06	S	•						120B027	SI 249,00	•	BMW	-	-
R 1100S int. ABS	R2S/R11S	01-06	S	•						120B027ABS	SI 199,00	•	BMW	-	-
R 1200S	R12S	06-	G							120B030	SI 259,00	•	Superb. flat, steel	-	-
K 1200RS	589/K12	97-00	S	•						120B022	SI 219,00	•	Superbike	-	-
K1200S	K12S	04-08	G							120B028	SI 319,00	•	Superbike	-	130B028
K1200S	K12S	04-08	G							120B028SW	319,00	•	Superbike	-	130B028
K1200R	K12R	05-08	G		•					120B029	SI 369,00	•	Superbike flat	-	-
K1200R	K12R	05-08	G		•					120B029SW	369,00	•	Superbike flat	-	-
K1300S	K12S	09-	G							120B028	SI 319,00	•	Superbike	-	130B028
K1300S	K12S	09-	G							120B028SW	319,00	•	Superbike	-	130B028
K1300R	K12S	09-	G		•					120B039	SI 419,00	•	Superbike flat	-	-
K1300R	K12S	09-	G		•					120B039SW	419,00	•	Superbike flat	-	-
Buell															
XB-9R/12R Firebolt	XB1	02-07	G	•						120BU04	SI 319,00	•	Superbike	-	-
Ducati															
Monster S4	M4	00-04								120D023	SI 269,00	•	Superbike	-	-
ST2/ST4	SI/S2	97-03								120D020	SI 269,00	•	Superbike	-	-
748/916/996/998	all	all	•							120D016	SI 599,00	•	Superbike	-	-
Honda															
CB-1	NC27	89-90	S	•						120H073	SI 219,00	•	Superbike	-	-
CBR 500R	PC44	13-15	A	•						120H142	SI 219,00	•	Superbike flat	-	-
XBR500/GB 500	PC15/16	all	S	•						120H016	SI 219,00	•	Superbike	-	-
CBR 600F	PC19/23	86-90	S	•						120H017	SW 219,00	•	Superbike	-	-
CBR 600F	PC25/31	91-98	S	•						120H045	SI 269,00	•	Superbike	-	-
CBR 600F	PC35	99-07	S	•						120H086	SW 299,00	•	Superbike	-	-
CBR 600F A	PC41	11-13	S	•	•					120H137	SW 299,00	•	Superbike flat	-	-
NTV 650	RC33	88-97	A	•						120H037	SW 219,00	•	Superbike	-	-
NT 650 Hawk	RC31	88-92	S	•						120H048	SI 219,00	•	Superbike	-	-
CB 750F	RC04	all	A	•						120H006	SW 199,00	•	Superbike	-	-
CBX 750F	RC17	84-86	A	•						120H005	SW 199,00	•	Superbike	-	-
VFR 750F	RC24	86-87	S	•						120H017	SW 219,00	•	Superbike	-	-
VFR 750F	RC24	88-89	S	•						120H041	SI 189,00	•	Superbike	-	-
VFR 750F	RC36	90-97	S	•						120H045	SI 269,00	•	Superbike	-	-
VFR 800F	RC46	98-01	S							120H081	SI 209,00	•	Superbike flat	-	-
VFR 800F	RC46	98-01	S							120H081SW	209,00	•	Superbike flat	-	-
VFR 800F	RC46	02-	S							120H098	SI 219,00	•	Superbike flat	-	-
CB 900F	SC01	all	A	•						120H006	SW 199,00	•	Superbike	-	-
CB 900F	SC09	all	A	•						120H006	SW 199,00	•	Superbike	-	-
CBR 900RR	SC28	92-93	G	•						120H047	SI 369,00	•	Superbike	-	131SP01/131SP01
CBR 900RR	SC28/33	94-97	G	•						120H047	SI 369,00	•	Superbike	-	131SP01/131SP01

model	type	year	version (page. 73)	brake line/-s	clutch line/-cable	throttle cable/-s	fairing support	cut windshield	cut fairing	item no	EUR	X-Bar clamping 22 mm clamping	recommended handlebar - please order in addition	handlebar extension	mirror bracket required - please order in addition left/right
			included	!	Sl: silver	SW: black	Ø	! please order these parts in addition							
Honda															
CBR 900RR	SC33	98-99	G	•	•	•	•	•	•	120H082	SI 419,00	•	Superbike	-	-
CBR 900RR	SC44	00-01	G	•	•					120H090	SI 389,00	•	Superbike	-	-
CBR 900RR	SC50	02-03	G	•	•					120H096	SI 389,00	•	Superbike flat	135-LV4...	-
CBR 1000F	SC21/24	89-92	S							120H045	SI 269,00	•	Superbike flat	-	-
CBR 1000F	SC24	93-00	S							120H041	SI 189,00	•	Superbike	-	-
CBR 1000RR	SC59	08-	G	•	•					120H125	SI 369,00	•	Superbike flat	135-LV4...	-
CBR 1000RR ABS	SC59	09-11	G	•	•					120H131	SI 349,00	•	Superbike flat	135-LV4...	-
VTR 1000F	SC36	97-06	S	•	•			•	•	120H075	SI 329,00	•	Superbike	-	-
CB 1100 SF X 11	SC42	00-03	A							120H091	SW 189,00	•	Superbike	-	-
CBR 1100XX	SC35	97-98	S	•				•		120H074	SI 229,00	•	Superbike	-	-
CBR 1100XX	SC35	99-	S	•	•					120H089	SI 349,00	•	Superbike	-	-
VFR 1200F	SC63	10-	S							120H133	SW 209,00	•	Superbike flat	-	-
VFR 1200FD DCT	SC63	10-	S							120H136	SW 209,00	•	Superbike flat	-	-
Kawasaki															
GPZ 500S	EX500A	88-93	A	•						120K022	SI 209,00	•	Superbike	-	-
GPZ 500S	EX500D	94-03	S							120K068	SW 209,00	•	Superbike	-	-
GPZ 600R	ZX600A	85-89	A	•						120K011	SI 199,00	•	Superbike	-	-
ZZR-600	ZX600D	90-92	A	•						120K046	SI 209,00	•	Superbike	-	-
ZZR-600	ZX600E	93-05	A	•				•		120K046	SI 199,00	•	Superbike	-	-
ZX-6R	ZX600G	98-99	A	•				•	•	120K083	SI 199,00	•	Superbike	-	-
GPX 750R	ZX750F	87-88	A	•						120K014	SI 199,00	•	Superbike	-	-
ZXR-750	ZX750J/K	91-92	G	•				•	•	120K050	SI 329,00	•	Superbike	-	131SP01/131SP01
ZXR-750	ZX750L/M	93-94	G	•				•	•	120K057	SI 369,00	•	Superbike	-	131SP01/131SP01
GPZ 900R	ZX900A	84-89	A	•						120K005	SW 199,00	•	Superbike	-	-
ZX-9R	ZX900B	94-97	G	•				•	•	120K061	SI 289,00	•	Superbike	-	-
ZX-9R	ZX900C	98-99	G	•	•			•	•	120K084	SI 289,00	•	Superbike	-	131SP02.1/131SP01
GPZ 1000RX	ZXT00A	all	A	•						120K019	SW 199,00	•	Superbike	-	-
ZX-10	ZXT00B	88-90	A	•						120K020	SW 199,00	•	Superbike	-	-
ZX-10R	ZXT00C	04-05	G	•						120K105	SI 389,00	•	Superbike flat	-	-
Z1000 SX ABS	ZXT00W	17-	S							120K138	SW 209,00	•	Superbike	-	-
Z1000 SX ABS	ZXT00G	11-16	S							120K138	SW 209,00	•	Superbike	-	-
GPZ 1100	ZXT10E	95-	A	•						120K078	SI 209,00	•	Superbike	-	-
ZZR-1100	ZXT10C	90-92	A	•						120K045	SI 209,00	•	Superbike	-	-
ZZR-1100	ZXT10D	93-	A	•						120K058	SI 229,00	•	Superbike	-	-
ZZR-1200	ZXT20C	02-	A	•						120K100	SI 209,00	•	Superbike flat	-	-
ZX-12R	ZXT20A	00-01	G	•	•					120K095	SI 379,00	•	Superbike flat	-	-
ZX-12R	ZXT20A	02-03	G	•	•					120K097	SI 379,00	•	Superbike flat	-	-
ZX-12R	ZXT20A	04-	G	•	•					120K106	SI 389,00	•	Superbike flat	-	-
ZZR-1400	ZXT40A/C	06-11	G	•						120K115	SI 369,00	•	Superbike flat	-	-
ZZR-1400	ZXT40E/F	12-14	G	•						120K142	SI 369,00	•	Superbike flat	-	-
GTR 1400	ZGT40A/C	07-09/10-	A	•						120K130	SI 299,00	•	Tour Bar	-	-
Moto Guzzi															
V11	V11	all	S							120M013SW	99,00	•	Superbike	-	-
V11	V11	all	S							120M013SI	99,00	•	Superbike	-	-
Suzuki															
GSX 600F	GN72B	-97	A	•						120S035	SI 219,00	•	Superbike	-	-
GSX 600F	AJ	98-	S							120S069	SI 219,00	•	Superbike	-	-
RF 600R	GN76B	all	A	•				•	•	120S050	SW 199,00	•	Superbike	-	-
GSX-R 600	WVB2	04-05	G	•						120S097	SI 329,00	•	Superbike flat	135-LV4...	-
GSX-R 600	WVCE/CV	06-10	G	•	•					120S108	SI 329,00	•	Superbike flat	-	-
GSX-R 600	C3	11-	G	•	•					120S127	SI 319,00	•	Superbike	-	-
SV 650S	AV	99-02	G	•	•			•	•	120S076	SI 369,00	•	Superbike flat	-	-
SV 650S	WVBY	03-08	G	•						120S091	SI 349,00	•	Superbike flat	-	-
SV 650SA ABS	WVBY	07-08	G	•						120S116	SI 329,00	•	Superbike flat	-	-
GSX 750F	GR78A/AK	89-02	A	•						120S037	SW 219,00	•	Superbike	-	-
GSX 750F	WVAK	03-06	A	•						120S105	SW 199,00	•	Superbike	-	-
GSX-R 750	GR7AB	90-91	G	•				•	•	120S038	SI 289,00	•	Superbike	-	131SP03.1/131SP01
GSX-R 750W	GR7BB	92-93	G	•				•	•	120S044	SI 289,00	•	Superbike	-	131SP03.1/131SP01
GSX-R 750W	GR7BB	94-95	G	•				•	•	120S053	SI 299,00	•	Superbike	-	131SP03.1/131SP01
GSX-R 750	GR7DB	96-99	G	•				•	•	120S063	SI 299,00	•	Superbike	-	131SP03.1/131SP01
GSX-R 750	WVBD	00-03	G	•				•	•	120S082	SI 349,00	•	Superbike	-	-
GSX-R 750	WVBD	04-05	G	•						120S097	SI 329,00	•	Superbike flat	-	-
GSX-R 750	WVCF/CW	06-10	G	•	•					120S108	SI 329,00	•	Superbike flat	-	-
GSX-R 750	C4	11-	G	•	•					120S127	SI 319,00	•	Superbike	-	-
TL 1000S*	AG	all	G	•				•	•	120S065	SI 299,00	•	Superbike	-	131SP03.1/131SP01
SV 1000S	WVBX	03-05	G	•	•					120S093	SI 369,00	•	Superbike flat	-	-
GSX-R 1000	WVBL	01-02	G	•				•	•	120S082	SI 349,00	•	Superbike	-	-

_ SUPERBIKE KITS

model	type	year	version (page. 73)	brake line/-s	clutch line/-cable	throttle cable/-s	fairing support	cut windshield	cut fairing	item no	EUR	X-Bar clamping 22 mm clamping	recommended handlebar – please order in addition	handlebar extension	mirror bracket required – please order in addition left/right
			included	!	!	!	!	!	!	Sl: silver SW: black	Ø	! please order these parts in addition			
Suzuki															
GSX-R 1000	WVBZ	03-04	G	*						120S094	SI 329,00	*	Superbike	-	-
GSX-R 1000	WVB6	05-06	G	*						120S099	SI 319,00	*	Superbike flat	-	-
GSX-R 1000	WVCL	07-08	G	*	*					120S114	SI 349,00	*	Superbike flat	-	-
GSX-R 1000	WVCL	07-08	G	*	*					120S114SW	349,00	*	Superbike flat	-	-
GSX-R 1000	WVCY	09-11	G	*						120S123	SI 329,00	*	Superbike flat	135-LV4...	-
GSX-R 1000	WVCY	12-14	G	*						120S130	SI 329,00	*	Superbike flat	-	-
GSX 1100F	GV72C	88-95	A	*						120S031	SW 219,00	*	Superbike	-	-
GSX-R 1100	GV73C	89-92	A	*				*		120S023	SI 219,00	*	Superbike	-	131SP01/131SP01
GSX-R 1100	GV73C	90-92	G	*				*		120S039GB	SI 289,00	*	Superbike	-	131SP01/131SP01
GSX-R 1100W	GU75C	93-96	A	*				*		120S049AP	SI 199,00	*	Superbike	-	131SP01/131SP01
GSX-R 1100W	GU75C	95-96	G	*				*		120S059GB	SI 299,00	*	Superbike	-	131SP01/131SP01
GSX 1300R Hayabusa	WVA1	99-07	A	*	*			*		120S077	SW 309,00	*	Superbike	-	-
GSX 1300R Hayab. o. ABS	WVCK	08-12	A	*				*		120S120	SW 269,00	*	Superbike	-	-
GSX 1300R Hayabusa ABS	WVCK	13-	A	*				*		120S132	SW 279,00	*	Superbike	-	-
* Replacement of steering damper necessary!															
Triumph															
TT 600	806AD	00-03	S	*						120T022	SW 229,00	*	Superbike	-	-
Speed Four /Daytona 600	806LB /LW	02-05	S	*						120T022	SW 229,00	*	Superbike	-	-
Thruxton 900	986ME	04-07	G	*						120T031SI	309,00	*	Superbike	-	-
Trident /Trophy 900	T300/C/E	92-01	A	*						120T003	SI 179,00	*	Superbike	-	-
Daytona 750 /900	T300	92-93	A	*				*		120T001	SI 199,00	*	Superbike	-	-
Sprint 900	T300A	93-98	A	*						120T003	SI 179,00	*	Superbike	-	-
Sprint Sport	T300A	97-98	A	*						120T003	SI 179,00	*	Superbike	-	-
Daytona 900 /Super III	T300B/D	94-96	A	*				*		120T002	SI 199,00	*	Superbike	-	-
Speed Triple	T300B	94	S	*						120T005	SW 219,00	*	Superbike	-	-
Sprint RS	T695/AC	00-04	A	*						120T023	SI 239,00	*	Superbike	-	-
Sprint ST no heatgrips	T695/AB	99-04	A	*	*					120T018	SI 259,00	*	Superbike	-	-
Sprint ST no heatgrips	215NA	05-10	A	*	*					120T034	SI 269,00	*	Superbike	-	-
Daytona T595 /955i	T595	97-01	G	*						120T014	SI 349,00	*	Superbike	-	-
Daytona 955i	595N	02-03	G	*						120T025	SI 319,00	*	Superbike	-	-
Daytona 955i	595N	04-05	G	*						120T032	SI 349,00	*	Superbike flat	-	-
Thruxton 1200	DE01/1/2	16-	G	*						120T072SW	449,00	*	Superbike 25,4 mm	-	130T072SW
Thruxton 1200 R	DE01/1/1	16-	G	*						120T071SW	459,00	*	Superbike flat	-	130T071SW
Daytona 1200	T300D	94-97	A	*				*		120T002	SI 199,00	*	Superbike	-	-
Trophy 1200	T300 /E	93-03	A	*				*		120T002	SI 199,00	*	Superbike	-	-
Yamaha															
SRX600	1XM/L	86-89	A	*						120Y024	SI 209,00	*	Superbike	-	-
XJ600	51J	84-91	A	*						120Y037	SW 209,00	*	Superbike	-	-
FZR 600	3HE	89-93	G	*	*					120Y035	SI 289,00	*	Superbike	-	131SP01/131SP01
FZR 600R	4JH	94-95	G	*	*					120Y057	SI 329,00	*	Superbike flat	-	/131SP01
YZF 600R	all	96-02	G	*	*			*		120Y069	SI 329,00	*	Superbike	-	/131SP01
SZR 660	4SU	96-97	A	*	*			*		120Y072	SI 249,00	*	Superbike flat	-	-
FZ750	all	85-93	A	*						120Y023	SW 209,00	*	Superbike	-	-
YZF 750R	all	93-	G	*				*		120Y054	SI 329,00	*	Superbike flat	-	131SP01/131SP01
TRX 850	4UN	95-00	G	*				*		120Y071	SI 329,00	*	Superbike	-	/131SP01
XJ900	31A/58L/4BB	83-95	A	*						120Y038	SW 209,00	*	Superbike	-	-
FZR 1000	2LA	87-88	A	*	*					120Y027	SI 209,00	*	Superbike	-	/130SAL1
FZR 1000	3LE	89-90	A	*	*					120Y029	SI 219,00	*	Superbike	-	131SP2.1/131SP01
FZR 1000	3LE	91-93	A	*	*					120Y046AP	SI 209,00	*	Superbike	-	131SP01/131SP01
FZR 1000	3LE	91-93	G	*	*					120Y046GB	SI 299,00	*	Superbike	-	131SP01/131SP01
FZR 1000	3LE	94-95	A	*	*					120Y058AP	SI 249,00	*	Superbike	-	131SP01/131SP01
FZR 1000	3LE	94-95	G	*	*					120Y058GB	SI 349,00	*	Superbike	-	131SP01/131SP01
YZF 1000R	all	96-00	G	*	*			*		120Y070	SI 369,00	*	Superbike	-	131SP01/131SP01
YZF-R1	RN01	98-99	G	*	*			*		120Y077	SI 369,00	*	Superbike	-	131SP2.1/131SP01
YZF-R1	RN04	00-01	G	*	*			*		120Y085	SI 399,00	*	Superbike	-	131SP2.1/131SP01
YZF-R1	RN09	02-03	G	*	*			*		120Y088	SI 399,00	*	Superbike flat	-	130Y088
YZF-R1	RN12	04-05	G	*	*			*		120Y094	SI 399,00	*	Superbike flat	-	-
YZF-R1	RN12	04-06	G	*	*			*		120Y108	SI 399,00	*	Superbike flat	-	130Y108
YZF-R1	RN22	09-11	G	*	*			*		120Y120	SI 349,00	*	Superbike flat	-	130Y120
YZF-R1	RN22	12-14	G	*	*			*		120Y133SW	369,00	*	Superbike flat	-	130Y120
FJ 1100/1200	all	84-97	A	*						120Y047	SW 209,00	*	Superbike	-	-
FJ 1200A ABS	3YA	91-95	A	*						120Y047ABS	SW 199,00	*	Superbike	-	-
FJR 1300	RP04/08/11	01-05	A	*						120Y087	SI 179,00	*	Naked Bike	-	-
FJR 1300	RP04/08/11	01-05	A	*						120Y087H	SI 169,00	*	Tour-Bar	-	-

TIPS SUPERBIKE KITS

- _ LSL delivers matching windscreens if required.
- _ To replace the mirrors mounted on fairing, we offer the right alternative, look at page 53, brackets for mounting mirrors on the handlebar you will find on page 56.
- _ Please also order the matching bar end weights, shown from page 50 - 52.
- _ All parts are available as spare parts as well.
- _ The top yokes and adapters have same colour as the original one (see table).

 Depending on model please order required parts in addition. There are a lot of products which make sense as well.

Do not forget to order handlebar weights. All handlebar weights fit our 14mm aluminum handlebars and steel handlebars with an internal diameter of 18 mm.

see from page 50

Often the mirror visibility is limited due to the wider superbike handlebar. In this case order a separate mirror for handlebar mounting. The Gonia eMark mirror is only used here as an example. Any other mirror from the LSL programme can be used.

see from page 53

Some bike models lack the threaded hole for the mirror mounting. For these models separate mirror mounts are listed in the table. These must be ordered separately.

see from page 56

For the models in which the fairing or windscreen needs to be cut, LSL provides already shortened screens. Our sales staff would be happy to help you.

Mail: info@lsl.eu or phone. : +49 - (0) 2151 - 5559 0

from EUR 94,95



NEW



_ REARSETS





REARSETS - 2SLIDE

Nowhere is the function and reliability of a rearset put to the test more than in a 24-hour endurance race. Reason for LSL, for many years to be active with its own team (an interesting report on our spectacular Le Mans appearance can be found on our website www.lsl.eu under „racing“).

Thorough testing and race track development led to the now well established LSL adjustable rearset – the 2Slide. Its design reflects the status of technology in the world of racing. The arrangement of the footrests can be adjusted horizontally in four positions. The position of the pegs can be adjusted longitudinally by 4 positions whilst the height can be shifted in two slides, hence the name to the product. The pegs are short and have a rough knurled grip, the base plates and levers are anodized.

The gear lever is designed in a banana-shape to avoid shifting during active cornering movement. The length adjusting

of the gear shift rod is achieved through interchangeable distances.

Often the original foot peg position is positioned too far forward, a problem which needed to be solved for the current Street Triple Cup. LSL had the professional solution ready - the footrest system used by Arne Tode on Daytona 675 which made him the German champion.

Performance rearsets 2Slide

- _ Longitudinal: 30mm; 4 settings vertical: 22mm; 2 slides
- _ Grippy knurled pegs
- _ All 2Slide rearsets are anodised in black

LSL PERFORMANCE



8-WAY ADJUSTABLE

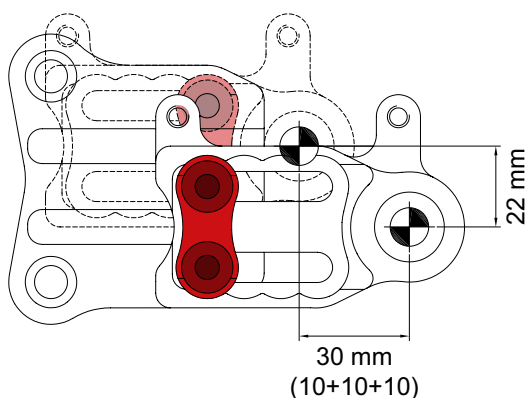

adjusting range horizontal: 30 mm steps, 4 settings
vertical: 2 settings, 22 mm difference



2Slide rearset on Kawasaki ZX-10R

ORDER INSTRUCTIONS

2SLIDE REARSETS

Upon request, the 2Slide is supplied free of charge with fixing pieces in other colors (red by default). Delivery without surcharge! For this purpose, please add the item number with the above number. (for example for a blue fixing 118+BL)

colour mounting pieces	order info
black	rearsset and 118+SW
silver	rearsset and 118+SI
gold	rearsset and 118+GO
blue	rearsset and 118+BL
red	red mounting pieces = standard

COLOUR



rearsset incl. foot pegs



different coloured mounting peaces (see table)



if necessary brake line (see table)

model	type	year	item no	EUR	brake line	EUR
Aprilia						
Tuono/RSV 1000	RR	04-11	118A015	429,00	225BS78AB	49,95
RSV 4R	RK	10-	118A022	429,00	225BS63BE	49,95
<i>reverse shifting: turn gear shifter / both rear positions are not possible with original muffler</i>						
Tuono RSV 4 / APRC	RK	11-14	118A023	429,00	225BS63BE	49,95
Tuono V4 1100 RR /Factory	TY	15-	118A023	429,00	-	-
BMW						
S 1000RR ABS with quick shifter	K10	09-14	118B040	429,00	-	-
conversion kit reverse shifting			118B040-R	129,95	-	-
conversion kit quick shifter			118B040QS	39,95	-	-
conversion kit quick shifter and reverse shifting			118B040QSR	24,95	-	-
S 1000RR	K10	15-	118B051	469,00	-	-
Honda						
CBR 600RR	PC37	03-06	118H099	429,00	225BS54BB	49,95
CBR 600RR	PC40	07-	118H117RR*	429,00	225BS52BB	49,95
CBR 900RR	SC44	00-01	118H090	429,00	-	-
CBR 900RR	SC50	02-03	118H096	429,00	-	-
VTR 1000 SP1/2	SC45	00-05	118H093	449,00	-	-
CBR 1000RR	SC57	04-05	118H103	429,00	225BS54BB	49,95
CBR 1000RR	SC57	06-07	118H103	429,00	225BS49BB	49,95
CBR 1000RR o. ABS	SC59	08-	118H125	429,00	-	-
CBR 1000RR ABS	SC59	09-	118H125	429,00	225BK52	89,95
CB 1000RA ABS	SC60	08-	118H127	429,00	-	-
<i>* for race use only</i>						
Kawasaki						
ZX-6R	ZX600G/J/636A	98-02	118K084	429,00	-	-
ZX-6R/RR	ZX636B/600K	03-04	118K101	419,00	225BS54BB	49,95
ZX-6R/RR	ZX636C/600N	05-06	118K107	419,00	225BS51BE	49,95
<i>reverse shifting: turn gear shifter, modify pinion cover</i>						
ZX-6R	ZX600P	07-08	118K120	419,00	225BS54BE	49,95
<i>reverse shifting: turn gear shifter, modify lever or use lever from model 05-06</i>						

model	type	year	item no	EUR	brake line	EUR
Kawasaki						
ZX-6R	ZX600R	09-12	118K131	419,00	225BS61BE	49,95
ZX-6R	ZX600R	13-	118K131	419,00	225BS51EG18	49,95
ZX-6R 636 ABS	ZX636E	13-	118K146	419,00	225BS54DE	79,95
Z 750/R	ZR750L/N	07-/11-	118K124	419,00	-	-
ZX-9R	ZX900C/E	98-03	118K084	429,00	-	-
ZX-10R	ZXT00C	04-05	118K105	419,00	225BS59BE	49,95
ZX-10R	ZXT00D	06-07	118K114	419,00	225BS43AB	49,95
ZX-10R	ZXT00E/F	08-10	118K127	419,00	-	-
<i>reverse shifting: original turn gear shifter</i>						
ZX-10R	ZXT00J	11-	118K136	419,00	-	-
ZX-10R ABS	ZXT00J	11-15	118K136	419,00	225BK44	89,95
ZX-10R ABS	ZXT00S	16-	118K152	419,00	225BK44	89,95
Z 1000SX	ZXT00W	17-	118K135	419,00	225BS51EG18	49,95
Z 1000 /SX	ZXT00G	10-/11-16	118K135	419,00	225BS51EG18	49,95
KTM						
990 Super Duke	LC8EF1	05-	118KT07	429,00	-	-
RC8	RC8	08-	118KT09	429,00	-	-
1290 Super Duke R		14-	118KT15	429,00	-	-
Suzuki						
GSX-R 600	BG	01-03	118S082	419,00	-	-
GSX-R 600	B2	04-05	118S097	419,00	-	-
GSX-R 600	C3	11-	118S123	419,00	-	-
<i>reverse shifting: original turn gear shifter</i>						
GSX-R 750	BD	00-03	118S082	419,00	-	-
GSX-R 750	B3	04-05	118S097	419,00	-	-
GSX-R 750	C4	11-	118S123	419,00	-	-
<i>reverse shifting: original turn gear shifter</i>						
GSX-R 1000	BL	01-02	118S082	419,00	-	-
GSX-R 1000	BZ	03-04	118S094	419,00	-	-
GSX-R 1000	B6	05-06	118S099	419,00	-	-
GSX-R 1000	CL	07-08	118S114	419,00	-	-
<i>reverse shifting: original turn gear shifter</i>						
GSX-R 1000	CY	09-	118S123	419,00	-	-
<i>reverse shifting: original turn gear shifter</i>						
Triumph						
Street Triple 675	D67LD	08-12	118T037	439,00	225BS56EBE	49,95
Street Triple 675	L67LR/ 3	13-	118T053	439,00	-	-
Street Triple 675 ABS	L67LR/ 3	13-	118T053	439,00	225BS51E90G1	49,95
conversion kit quick shifter			118T053-QS	39,95	-	-
rearset for quick shifter			118T053QS	439,00	225BS51E90G1	49,95
conversion kit reverse shifting			118T053-R	99,95	-	-
rearset with reverse shifting unit			118T053R	449,00	225BS51E90G1	49,95
conversion kit quick shifter and reverse shifting			118T053-RQS	99,95	-	-
rearset for quick shift and reverse shifting			118T053RQS	449,00	225BS51E90G1	49,95
Daytona 675	D67LC	06-12	118T037	439,00	-	-
rearset with reverse shifting unit			118T037RR	459,00	-	-
Daytona 675R	H67	13-	118T055	499,00	225BS41E90G1	49,95
rearset for quick shift			118T055QS	499,00	225BS41E90G1	49,95
Street Triple 765 ABS		17-	118T075	in prep.	-	-
Daytona/Speed Triple	T509/T595/595N	99-04	118T025	449,00	-	-
Speed Triple 1050	515NJ	05-11	118T033	449,00	-	-
Speed Triple 1050	515NV	11-15	118T046	449,00	-	-
fitting bracket for lower exhaust system			118T046LE	12,95	-	-
<i>reverse shifting: turn gear shifter, remove side stand</i>						
Yamaha						
YZF-R6	RJ05/09	03-05	118Y089	439,00	-	-
YZF-R6	RJ11/15	06-13	118Y104	439,00	-	-
MT-07 (ABS)	RM041	14-	118Y134	449,00	-	-
XSR 700 ABS	RM11	15-	118Y134	449,00	-	-
FZ 8/Fazer	RN25	10-	118Y106	439,00	-	-
MT-09 /Tracer	RN29 /F	14-	118Y129	479,00	-	-
MT-09		17-	118Y146	in prep.	-	-
XSR 900 ABS	RN431	16-	118Y129	479,00	-	-
YZF-R1	RN12	04-06	118Y094	439,00	-	-
<i>normal and reverse shifting is possible</i>						
YZF-R1	RN22	09-14	118Y120	439,00	-	-
YZF-R1M	RN322	15-	118Y137	439,00	-	-
<i>w/o brake light swich, for race use only</i>						
FZ 1/Fazer	RN16	06-	118Y106	439,00	-	-

NEW
NEW

_ REARSETS **LSL REARSETS**



BRACKET SYSTEM - **LSL REARSETS**

Form follows Function - LSL design is a result of the individual components and is still performed on the current vehicle models. This structural element combines rigidity with light-weight and attractive appearance.

The shift and brake levers are made of high-strength aluminum. Based on an intensive endurance racing experience the levers are mounted by means of PTFE-coated sliding bushings.

All rearsets can optionally be equipped with foldable joints for the rider pegs. All LSL components are weather resistant anodized.



BMW R nineT

Back shifted rearset, ideal for Café Racer conversions.



Harley Davidson Sportster / Roadster

The back shifted rearset for the present Sportster-Models, requirement for a dynamic seating position.



Kawasaki ER-6, Suzuki Gladius

LSL also offers appropriate rearsets for the bread-and-butter bikes, a must for Mini-Twins and Gladius Cup.



Kawasaki W 650/800

As an alternative to the well-known Cafe Racer system there is also a moderate back shifted version for a combination with high handlebar.



Moto Guzzi V7 / V9

Sporty back shifted rearset for the handy V- models from Moto Guzzi.



Triumph Thruxton 900

The series version is rather too far back, the LSL rearset gives a much better peg position.



Yamaha XS 650

The XS community has been waiting for a long time – a back shifted rearset with usage of the kickstarter.



Yamaha XJR 1300

Not only Yamaha had a facelift in 2015, also LSL revised the classically drawn levers completely.



Performance LSL Rearsets

- _ Mounting plates and levers weather-resistant anodized
- _ Aluminum shift rods with external hexagon for perfect adjustment
- _ Bushing in PTFE, bearing width 18 mm
- _ Pegs on request foldable
- _ Extreme pegs surcharge possible

TIPS

LSL REARSETS

Standard LSL rearsets will be delivered with fixed foot peg linkings and pegs in silver. On demand we can deliver foldable adaptations and pegs in other colours.



+ New stainless steel brake line needs to be ordered when listed (see table, last column).

(+) For an extra charge LSL rearsets can be equipped with a foldable bracket (see table on page 86).

(+) If you want the foot pegs in a different color, please advice - we will exchange at no extra costs. Please see the available colors on page 88.



ORDER INSTRUCTIONS LSL REARSETS

The corresponding offset of the foot pegs to the original position are specified in the table, please see the chart on the right.

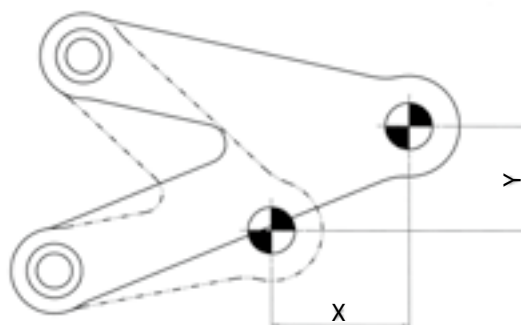

!
rearset with silver foot pegs
⊕
different coloured foot pegs for free (page 88)
⊕
if necessary brake line (see table)
⊕
foldable foot peg linkings

model	type	year	rear / up offset in cm	item no black	item no silver	EUR	brake line	EUR
BMW								
R 1100S ohne ABS	R2S/R11S	98-06	1.5 / 0.5-1.5	110B025	-	219,00	225BS41BD	49,95
R nine T	R1ST	14-	5.0 / 0.0	110B049SW	110B049	489,00	-	-
Buell								
Lightning X1	BL1	98-02	5.0 / 3.5	-	110BU03	369,00	-	-
XB-9R / 9S / 12R / 12S	XB1	05-10	1.0 / -0.5-2.5	-	110BU04	299,00	-	-
Ducati								
Streetfighter / 848 / 1098	F1	09-	1.0 / 1.0	110D037	-	239,00	-	-
Harley-Davidson								
XL 883/1200	XL1/XL	82-03	21.0 / 3.0	110HD01.1SW	110HD01.1	499,00	-	-
XL 883/1200 Sozius	XL1/XL	82-03	K.a.	110HD01.2SW	110HD01.2	159,00	-	-
Forty Eight ¹⁾²⁾⁴⁾	XL2	10-	42.0 / 1.0	110HD19SW	110HD19	719,00	-	-
XL 883/1200 Sportster ¹⁾²⁾³⁾⁴⁾	XL2	04-	17.0 / 0.5	110HD19SW	110HD19	719,00	-	-
XL1200X Roadster ABS	XL2	14-	1.8 / 3.0	110HD23SW	-	719,00	-	-
foldable foot peg linkings for Sportsters 110HD01.1				110-GLKHDSW	110-GLKHD	49,95	-	-
^{1) with 2 in 1 exhaust system only} ^{2) no passenger possible} ^{3) mModels without ABS only} ^{4) foldable foot peg linkings included}								
Honda								
CB 750 Seven Fifty	RC42	92-02	7.0 / 3.5	110H051SW	110H051	349,00	-	-
CBR 900RR	SC28	92-93	1.0 / 4.0	-	110H047	349,00	-	-
CBR 900RR	SC28/33	94-97	1.0 / 4.0	110H059SW	110H059	349,00	-	-
CBR 900RR	SC33	98-99	1.0 / 4.0	110H082SW	110H082	349,00	-	-
Kawasaki								
W 650	EJ650A	99-02	11.5 / 1.0	110K086SW	110K086	339,00	-	-
ER-6N / F ABS ¹⁾	ER650C	09-11	0 / +0.5 o. -1.5	-	110K133	329,00	-	-
ER-6N / S ABS	ER650E	12-	1.5 / 1.5	-	110K140	339,00	-	-
ZX-6R	ZX600F	94-97	4.5 / 3.5	110K050SW	110K050	329,00	-	-
ZXR-750 / ZX-7R	ZX750J/L/P	91-98	4.5 / 3.5	110K050SW	110K050	319,00	-	-
Z 750	ZR750J	04-06	3.0 / 1.0	-	110K102	329,00	-	-
Z 750 / R	ZR750L/N	07-	1.5 / 0.5	110K124SW	110K124	329,00	-	-
W 800	EJ800A	11-	10.0 / 1.0	110K137SW	110K137	339,00	-	-
W 800 Version Midi	EJ800A	11-	4.0 o. 6.0 / -1.5	110K137LBSW	110K137LB	349,00	-	-
ZX-9R	ZX900B	94-97	4.5 / 3.5	-	110K061	329,00	-	-
Z 1000 J/R ²⁾	KZT00J/R	81-83	7.5 / 2.0	-	110K007	369,00	-	-
Z 1000 ¹⁾³⁾	ZRT00A	03-06	3.0 / 1.0	-	110K102	329,00	-	-
Z 1000	ZRT00B	07-09	1.5 / 0.5	110K124SW	110K124	329,00	-	-
ZRX 1100/1200	ZRT10C/20A	97-06	6.5 / 4.0	110K082SW	110K082	329,00	225BS48AB	49,95
^{1) passenger not possible} ^{2) exhaust bracket right included, left bracket: item no 110K007.2} ^{3) passengers bracket for use with orig. exhaust required}								
Moto Guzzi								
V7 Spezial	LW	-11	7.5 / 1.5	110M018SW	110M018	439,00	-	-
V7 Spezial / Stone	LW	12-	7.6 / 1.5	110M019SW	110M019	319,00	-	-
V9 Bobber	LHA	16-	7.5 / 1.5	110M021SW	110M021SI	319,00	-	-
Le Mans 850/1000S	VE/VF/VV	all	12.0 / 3.5	-	110M001	399,00	225BS80EB2G19	57,95
front brake has to be changed to double front brake mode, for rear brake item no 241M001 is required (EUR 149,95).								
Suzuki								
GSF 600N/S	GN77B/A8	95-04	5.8 / 4.0	110S064SW	110S064	329,00	-	-
GSX-R 600	AD	97-00	3.5 / 2.7	110S063SW	110S063	329,00	-	-
GSX-R 600	BG	01-03	2.0 / 0.5	-	110S082	329,00	-	-
GSX-R 600	B2	04-05	2.0 / 0.5	-	110S097	319,00	-	-
GSX-R 600	CE	06-07	0.5 / 0.5	110S108SW	110S108	319,00	-	-
GSX-R 600	CV	08-10	0.5 / 0.5	110S108SW	110S108	319,00	-	-

_ REARSETS LSL REARSETS

model	type	year	rear / up offset in cm	item no black	item no silver	EUR	brake line	EUR
Suzuki								
GSX-R 600	C3	11-	0.6 / 3.3	-	110S127	319,00	-	-
GSF 650N/S Bandit	B5	05-06	5.8 / 4.0	110S064SW	110S064	319,00	-	-
SFV 650 Gladius ABS	WVCX	09-	0.8 / 3.0	110S124SW	-	329,00	-	-
SV 650N/S	AV	99-02	3.5 / 2.7	-	110S075	329,00	-	-
SV 650N/S	BY	03-04	6.5 / 2.5	-	110S091	329,00	-	-
SV 650N/S	BY	05-08	1.5 / 3.0	-	110S091	329,00	225BS40AB	49,95
SV 650 ABS	CX	16-	0.8 / 3.0	110S137SW	-	319,00	-	-
GSF 650N/S Bandit	CJ/CZ	07-	3.0 / 0.5	-	110S117	319,00	-	-
GSR 750 o. ABS	C5	11-	2.0 / 3.0	110S126SW	110S126	329,00	-	-
GSX-R 750	GR7DB	96-99	3.5 / 2.7	110S063SW	110S063	319,00	-	-
GSX-R 750	BD	00-03	2.0 / 0.5	-	110S082	319,00	-	-
GSX-R 750	B3	04-05	2.0 / 0.5	-	110S097	319,00	-	-
GSX-R 750	CF	06-07	0.5 / 0.5	110S108SW	110S108	319,00	-	-
GSX-R 750	CW	08-10	0.5 / 0.5	110S108SW	110S108	319,00	-	-
GSX-R 750	C4	11-	0.6 / 3.3	-	110S127	319,00	-	-
SV 1000N/S	BX	03-05	2.0 / 0.5	110S093SW	110S093	319,00	225BS42AC	49,95
GSX-R 1000	BL	01-02	2.0 / 0.5	-	110S082	319,00	-	-
GSX-R 1000	BZ	03-04	2.0 / 0.5	-	110S082	319,00	-	-
GSX-R 1000	CL	07-08	2.5 / 2.2	110S114SW	110S114	319,00	-	-
GSX-S 1000	DG	15-	1.0 / 1.0	110S135SW	110S135	329,00	-	-
GSF 1200N/S	GV75A/A9/CB	all	5.8 / 4.0	110S064SW	110S064	319,00	-	-
GSF 1250N/S / GSX1250F	CH	07-	3.0 / 0.5	-	110S117	319,00	-	-
B-King	CR	08-10	1.5 / 1.0	-	110S119	329,00	-	-
GSX 1300R Hayabusa	A1	99-07	3.5 / 2.0	110S077SW	110S077	339,00	-	-
GSX 1300R Hayabusa o. ABS	CK	08-	2.5 / 2.0	-	110S120	329,00	225BS47AB	49,95
Triumph								
Bonneville	908MD/986MF	02-15	12.0 / 3.0	110T024SW	110T024	349,00	-	-
Bonneville, rear	908MD/986MF	02-15	-	110T024.2SW	110T024.2	139,00	-	-
Thruxton 900	986ME/2	05-15	-3.7 / 0.4	110T031SW	110T031	319,00	-	-
				<i>Always foldable!</i>				
T-Bird Sport	T309RT	all	3.0 / 1.5	110T020SW	110T020	339,00	-	-
Daytona/Speed Triple	T509/595	97-98	1.5 / 1.2	-	110T014	319,00	-	-
Daytona/Speed Triple	T509/595	99-01	1.5 / 1.2	-	110T017	339,00	-	-
Daytona/Speed Triple	595N	02-04	1.5 / 1.2	110T025SW	110T025	339,00	-	-
Yamaha								
SR 400	RH05	10-	12.0 / 4.0	-	110Y033	339,00	-	-
SR 500	2J4/48T	78-99	12.0 / 4.0	-	110Y033	339,00	-	-
YZF-R6	RJ03	99-02	1.5 / 0.5	-	110Y079	339,00	-	-
XS 650	447	75-83	22,5 / 3,5	-	110Y017	459,00	-	-
YZF 750R/SP	all	93-96	3.0 / 2.7	-	110Y054	339,00	-	-
TRX 850	4UN	95-00	3.0 / 2.7	110Y071SW	110Y071	339,00	-	-
YZF 1000R	4VD	96-01	3.0 / 2.7	-	110Y070	339,00	-	-
YZF-R1	RN01/RN04	98-01	1.0 / 0.5	110Y077SW	110Y077	339,00	-	-
XJR 1200/1300 ¹⁾	all	95-	4.5 / 3.2	110Y139SW	110Y139	329,00	-	-
V-Max	all	85-04	10.0 / 2.5	110Y044SW	110Y044	349,00	225BS68BC	49,95
V-Max, Sozious	all	85-04	-	-	110Y044.2	139,00	-	-
^{1) passenger not possible}								
foldable foot peg linking								
Standard				110-GLKSW	110-GLKSI	49,95		
Harley-Davidson Sportster rearset 110HD01.1 or 110HD01.1SW				110-GLKHDSW	110-GLKHD	49,95		
Extreme Pegs								
More grip, in exchange for the standard racing pegs				110SW-04SW	110SI-04SW	44,00	Surcharge rearset	
<i>If listed the brake lines are required to mount the rearset correctly. Please order them in addition. All components are available as spare parts.</i>								



MACHINED SHIFT LEVERS

High quality CNC machined aluminum levers for selected models, they are mounted by the proven LSL PTFE coated bearing bush.

model	year	gear shifter	EUR	gear shifter/ brake shifter	EUR
Aprilia					
RSV 4 APRC	all	110A023.1	89,95	-	-
RSV 4 APRC revers	all	110A023.1R	89,95	-	-
Tuono V4 1100 RR/ Factory	15-	110A023.1	89,95	-	-
Tuono V4 1100 RR/ Factory	15-	110A023.1R	89,95	-	-
Buell					
M2	all	110BU01-1	159,00	110BU01-2	209,00
X1	all	110BU03-1	159,00	110BU03-2	209,00
Ducati Scrambler					
Icon/Classic/Full Throttle	15-	-	-	110D047SW	149,00
Icon/Classic/Full Throttle	15-	-	-	110D047SI	149,00
Cafe Racer/Sixty2	16-	-	-	110D047SW	149,00
Cafe Racer/Sixty2	16-	-	-	110D047SI	149,00
Suzuki					
GSF 650	07-	110S117-1	69,95	-	-
GSF/GSX 1250	07-	110S117-1	69,95	-	-
Triumph					
Thruxton	-15	110T031-1	69,95	110T031-2	135,95
Thruxton 1200 / R	16-	110T031-1	69,95	110T072-2	135,95

NEW



110A023.1R



Triumph Extreme

Triumph Extreme with toothing rough

Scrambler/Bonneville	-15	110T038EX	89,95	-	-
----------------------	-----	-----------	-------	---	---

SINGLE ITEMS FOR LSL REARSETS

All rearset items can also be purchased as a single item in silver and black.



product	item no	item no	EUR
shift knob / brake knob			
shift knob smooth	111-001SI	111-001SW	6,95
brake knob milled	111-002SI	111-002SW	6,95



length	item no	item no	EUR
shift rods with 10mm hexagon			
50 mm	119-S49	119-S49SW	16,95
75 mm	119-S53	119-S53SW	16,95
85 mm	119-S52	119-S52SW	16,95
100 mm	119-S51	119-S51SW	16,95
112 mm	119-S48SI	119-S48SW	16,95
130 mm	119-K12SI	119-K12SW	16,95



111-H07SW

111-T22SI

length	offset	item no	item no	EUR
lever for gear shift				
36 mm	-	111-H07SI	111-H07SW	49,95
41 mm	19 mm	111-T22SI	111-T22SW	49,95



type	thread	item no	EUR
ball joints			
M6	Außengewinde	112-GLA6	9,95
M6	Außen-/Linksgewinde	112-GLA6L	10,95
M6	Innengewinde	112-GLI6	9,95
M6	Innen-/Linksgewinde	112-GLI6L	10,95
M8	Innengewinde, kurz	112-GLI8K	14,95

_ REARSETS FOOD PEGS

FOOD PEGS WITH ABE-APPROVAL

The LSL replacement pegs are made of high quality aluminum and available in different colors. The surface is knurled for extra grip, the racing pegs have the extra strong knurling up to the outer edge.

Precisely manufactured adapters provide fitment to most major motorcycles. You can find the ABE -approval model assignment on our website www.lsl.eu or you ask our staff.



FOOD PEG RACING



type	surface	colour	length	item no	EUR/pair
food pegs Racing					
Racing	anodised	silver	72 mm	115-03SI	29,95
Racing	anodised	black	72 mm	115-03SW	29,95
Racing	anodised	titan	72 mm	115-03TI	29,95
Racing	anodised	anthracite	72 mm	115-03AN	29,95
Racing	anodised	blue	72 mm	115-03BL	29,95
Racing	anodised	red	72 mm	115-03RT	29,95
Racing	anodised	gold	72 mm	115-03GO	29,95

FOOD PEG SPORT



type	surface	colour	length	item no	EUR/pair
food pegs Sport					
Sport	anodised	silver	85 mm	115-01SI	29,95
Sport	anodised	black	85 mm	115-01SW	29,95
Sport	anodised	titan	85 mm	115-01TI	29,95
Sport	anodised	blue	85 mm	115-01BL	29,95
Sport	anodised	red	85 mm	115-01RT	29,95
Sport	anodised	gold	85 mm	115-01GO	29,95

FOOD PEG RACING II WITH RUBBER LINER



type	surface	colour	length	item no	EUR/pair
food pegs Racing II, with rubber liner					
Racing	anodised	silver	72 mm	115-06SI	29,95
Racing	anodised	black	72 mm	115-06SW	29,95

FOOD PEG EXTREME



type	surface	colour	length	item no	EUR/pair
food pegs Extreme					
Extreme	anodised	black	78 mm	115-04SW	69,95



_ REARSETS **FOOD PEG LINKING**



ADJUSTABLE **FOOD PEG LINKING**

Matching foot position by 8-way adjustable CNC milled foot-rest hinges. The system allows both a sporty high position and a low comfortable position. And who likes to vary – can quickly adjust with a hexagonal socket key to a new position – ready. The adjustment (50 mm circle) is achieved by the adjustable lever into eight positions. Sold in pairs (with approval) for many models (see list on page 91).

Important Info:

Low set pegs can reduce the lean angle and cause that the boots touch the exhaust. Also widely changed foot rests effect the distance to shift and brake levers. Please always select the optimal foot rest position and don't make any compromise regarding road safety.

food pegs (see left)



linking (standard or adjustable)



FOOD PEG LINKING STANDARD

different performances depending on your model



FOOD PEG LINKING ADJUSTABLE

Available for a lot of models





EXTREME FOOT PEG WITH LINKING

Strong milled from solid, high-strength 7075 alloy, pegs with coarse teathed and hard-anodised surface. A foldable protection supports the bike when falling.

model	colour	item no	EUR
Extreme foot peg	linking/foot peg		
Ducati Scrambler Icon	15- silver/black	115D047FEX	139,95
Triumph Scrambler/Bonneville -15	silver/black	115T038FEX	139,95
Yamaha XV 950	silver/black	115Y131FEX	139,95



ADJUSTABLE FOOT PEG LINKING

LSL foot peg bracket kits can be ordered separately for universal mounting (if no specific linking is available for you model). Springs and washers are made of stainless steel, for the fastening M8 flat head screws are used. Mounting with M8 shallow head screws. New are special sets for BMW R 80/100R and Triumph Thruxton 1200 models.

universal	colour	item no	EUR/pair
foldable foot peg linking, foot pegs not included			
foot peg linking	silver	110-UNI	79,95
foot peg linking	black	110-UNISW	79,95



model	type	year	foot pegs linking					
			lease order foot pegs in addition, check types on page 88					
/... = also for this model (ABS) = also for models with ABS ABS = for models with ABS only			standard				pair EUR 89,95	
			front	EUR	rear	EUR	adjustable front	rear
Aprilia								
RS 250 Replica	LD /LD01	95-01	115-T05	29,95	115-A01	29,95	114-T05	-
SL 750 Shiver /GT (ABS)	RA	07-	115-S13	29,95	115-A03	29,95	114-S13	-
SMV 750 Dorsoduro (ABS)	SM	08-	-	-	115-A03	29,95	-	-
NA 850 Mana /GT (ABS)	RC	07-	115-S13	29,95	115-A03	29,95	114-S13	-
RSV 1000R /Factory /Nera	RR	04-07	115-S13	29,95	115-A02	29,95	114-S13	-
RSV4 R /Factory /APRC	RK	09- /10-	115-S13	29,95	115-A02	29,95	114-S13	-
Tuono 1000R	RR	05-10	115-S13	29,95	115-A02	29,95	114-S13	-
Tuono V4R / APRC	TY	11-14	115-S13	29,95	115-A02	29,95	114-S13	-
Tuono V4 1100 Factory	TY	15-	115-S13	29,95	115-A02	29,95	-	-
BMW								
F 800S /ST /R (ABS)	E8ST	06-	115-B05	29,95	115-B06	39,95	114-B05	114-B06
R 100R	247E	91-96	115-B09	29,95	115B014R	79,95	-	-
S 1000RR (ABS)	K10	10-11	115-B07	29,95	115-B08	29,95	-	114-B06
S 1000RR (ABS)	K10	12-	115-B07	29,95	115-B08	29,95	-	-
S 1000R	K10	13-	115-B07	29,95	115-B08	29,95	-	114-B08
R nineT	R1ST	13-	115-B05	29,95	115-B08	29,95	114-B05	114-B08
K 1200 S /R Sport (ABS)	K12S /K12R	04-08	115-B05	29,95	115-B06	39,95	114-B05	114-B06
R 1200 ST / S (ABS)	R1ST /R12S	05-09 /07-	115-B05	29,95	115-B06	39,95	114-B05	114-B06
R 1200 R (ABS)	R1ST/0A04/A	06- /15-	115-B05	29,95	115-B06	39,95	114-B05	114-B06
R 1200 RS	R12WR	15-	115-B05	29,95	115-B06	39,95	114-B05	114-B06
K 1300 R/S (ABS)	K12S	08-	115-B05	29,95	115-B06	39,95	114-B05	114-B06
Buell								
Firebolt XB9R/S/Light./City X/12R	XB1	03-	115-BU2	29,95	115-BU3	29,95	-	-
Cyclone M 2 /2-2	EB1	98-02	115-BU1	29,95	115-BU1	29,95	-	-
Lightning S 1/S 1-2 /X1 Millenium	EB1 /BL1	96-02	115-BU1	29,95	115-BU1	29,95	-	-
Ducati								
Monster 600	M /M3	95-01	115-D03	29,95	115-D03	29,95	114-D03	114-D03
600 Super Sport	S	95-98	115-D01	29,95	115-D02	29,95	-	-
Monster 620 i.E. /S /Dark	M4	02-06	115-D03	29,95	115-D03	29,95	114-D03	114-D03
Monster 695	M4	07-08	115-D03	29,95	115-D03	29,95	114-D03	114-D03
Monster 696	M5	08-	115-D06	29,95	115-D07	29,95	-	-
748 /R /S	H3	99-02	115-D04	29,95	115-D03	29,95	114-D04	114-D03
748 S /SP /Biposto	748	96-99	115-D04	29,95	115-D03	29,95	114-D04	114-D03
749 /R /S	H5	02-07	115-D04	29,95	115-D03	29,95	114-D04	114-D03
750 Super Sport	ZDM750SC /S	92-98	115-D01	29,95	115-D02	29,95	-	-
750 Super Sport i.E.	V2	99-02	115-D04	29,95	115-D03	29,95	114-D04	114-D03
Monster 750 /i.E.	M /M1 /M4	98-02	115-D03	29,95	115-D03	29,95	114-D03	114-D03
Monster 800 /S /Dark	M4	03-07	115-D03	29,95	115-D03	29,95	114-D03	114-D03
Monster 821	M6	14-	115-D06	29,95	-	-	-	-
Scrambler Icon	K1	15-	115-D06	29,95	115-D09	29,95	-	114-D09
848 /EVO	H6	08-	115-D04	29,95	-	-	114-D04	-
Streetfighter 848	F1	12-	115-D08	29,95	115-D04	29,95	114-D08	114-D04
Panigale 899	H8	14-	115-D04	29,95	-	-	114-D04	-
900 Super Light /Super Sport	S /ZDM906SC2 /3	91-98	115-D01	29,95	115-D02	29,95	-	-
900 Super Sport i.E.	V1	99-02	115-D04	29,95	115-D03	29,95	114-D04	114-D03
Monster 900 /i.E.	M /M2	93-02	115-D03	29,95	115-D03	29,95	114-D03	114-D03
916 S /SP /Biposto	916	95-97	115-D04	29,95	115-D03	29,95	114-D04	114-D03
916 ST 4	S2	99-03	115-D01	29,95	115-D02	29,95	-	-
Monster S4 /Fogarty /S4R	M4	01-03	115-D03	29,95	115-D03	29,95	114-D03	114-D03
944 ST 2	S1	98-03	115-D01	29,95	115-D02	29,95	-	-
Sport 1000 /S /Paul Smart LE	C1	06-09	115-D04	29,95	-	-	114-D04	-
GT 1000 /Touring	C1	07-10	115-D04	29,95	-	-	114-D04	-
Monster 1000 /S /Dark	M4	03-08	115-D03	29,95	115-D03	29,95	114-D03	114-D03
996 /R /S	H2	98-01	115-D04	29,95	115-D03	29,95	114-D04	114-D03
996 ST 4	S2	01-03	115-D01	29,95	115-D02	29,95	-	-
996 ST 4S (ABS)	S3	01-06	115-D04	29,95	115-D03	29,95	114-D04	114-D03
Monster S4R /S2R	M4	04-06	115-D04	29,95	115-D05	29,95	114-D04	-
998 /R /S /Bayliss /Bostrom	H2	02-03	115-D04	29,95	115-D03	29,95	114-D04	114-D03
999 /R /S /Xerox	H4	03-06	115-D04	29,95	115-D03	29,95	114-D04	114-D03
Monster S4R S	M4	06	115-D04	29,95	115-D03	29,95	114-D04	114-D03
Monster S4R /S Testar. /Tricolore	M4	07-08	115-D04	29,95	115-D05	29,95	114-D04	114-D05
Monster 1100 /S /EVO (ABS)	M5	09-	115-D06	29,95	115-D07	29,95	-	-
1098 /S	H7	07-08	115-D04	29,95	-	-	114-D04	-
Streetfighter 1098 /S	F1	09-	115-D04	29,95	115-D04	29,95	114-D04	114-D04
1098 /R /S /SP /Bayliss LE /1198	H7	08-11	115-D04	29,95	-	-	114-D04	-
Panigale 1199	H8	12-	115-D04	29,95	-	-	114-D04	-
Multistrada 1200 /S (ABS)	A2	10-	115-D06	29,95	-	-	-	-
Monster 1200 /S	M6	14-	115-D06	29,95	-	-	-	-

NEW

_ REARSETS FOOD PEG LINKING

model	type	year	foot pegs linking				pair EUR 89,95	
			standard front	EUR	rear	EUR	adjustable front	rear
			lease order foot pegs in addition, check types on page 88					
/... = also for this model (ABS) = also for models with ABS ABS = for models with ABS only								
Harley-Davidson								
V-Rod, Dyna, Softail, Sportster, XR1200	all	all	115-BU1	29,95	115-BU1	29,95	-	-
XL1200CX Roadster ABS	XL2	14-	115-B01	29,95	115-B01	29,95	-	-
Honda								
CBR 125R	JC34 /39	04-10	115-H09	39,95	115-H07	39,95	-	-
CB 500 /S	PC26 /32	94-03	115-H01	29,95	-	-	114-H01	-
CBF 500 (ABS)	PC39	04-08	115-H01	29,95	115-H06	39,95	114-H01	-
CB 500 RA /FA	PC44 /45	13-	115-H01	29,95	115-H07	39,95	114-H01	-
CB 600 F/S Hornet /Hornet-S	PC34	98-01	115-H01	29,95	115-H07	39,95	114-H01	-
CB 600 F/S Hornet /Hornet-S	PC36	02-	115-H01	29,95	115-H06	39,95	114-H01	-
Hornet 600	PC36	02-06	115-H01	29,95	115-H06	39,95	114-H01	-
Hornet 600 (ABS)	PC 41	07-	115-H01	29,95	115-H02	29,95	114-H01	114-H02
CBF 600 N/S (ABS)	PC 38	04-07	115-H01	29,95	115-H06	39,95	114-H01	-
CBF 600 N/S (ABS)	PC 43	08-	115-H01	29,95	115-H10	39,95	114-H01	-
CBR 600 F	PC19 /23 /25	87-94	115-H01	29,95	115-H04	39,95	114-H01	-
CBR 600 F	PC31 /35	95-07	115-H01	29,95	115-H02	29,95	114-H01	114-H02
CBR 600 F (ABS)	PC41	11-	115-H01	29,95	115-H02	29,95	114-H01	114-H02
CBR 600 RR (ABS)	PC37 /40	03-	115-H01	29,95	115-H02	29,95	114-H01	114-H02
CB 650F	RC75	14-	115-H01	29,95	115-H12	29,95	114-H01	114-H12
CBR 650	RC74	14-	115-H01	29,95	115-H12	29,95	114-H01	114-H12
NC 700 SA /XA /750 S	RC61 /63 /70	12- // -15	115-H01	29,95	115-H12	29,95	114-H01	114-H12
CB 750 Seven Fifty	RC42	92-02	115-H01	29,95	115-H04	39,95	114-H01	-
VFR 750 F	RC36	90-97	-	-	115-H02	29,95	-	114-H02
VFR 800 F (ABS)	RC46	98-	115-H01	29,95	115-H02	29,95	114-H01	114-H02
VFR 800 X	RC80	15-	115-H01	29,95	115-H12	29,95	114-H01	114-H12
CB 900 F Hornet	SC48	01-05	115-H01	29,95	115-H06	39,95	114-H01	-
CBR 900 RR	SC28 /33 /44 /50	92-03	115-H01	29,95	115-H02	29,95	114-H01	114-H02
CB 1000 F	SC30	93-96	115-H01	29,95	115-H02	29,95	114-H01	114-H02
CB 1000 R (ABS)	SC60	08-	115-H01	29,95	115-H02	29,95	114-H01	114-H02
CBF 1000 /F (ABS)	SC58 /SC64	06-	115-H01	29,95	115-H10	39,95	114-H01	-
CBR 1000 F	SC21/24	87-99	115-H01	29,95	115-H04	39,95	114-H01	-
CBR 1000 RR (ABS)	SC57 /59	04-	115-H01	29,95	115-H02	29,95	114-H01	114-H02
CRF 1000L Africa Twin (ABS)	SD04	16-	-	-	115-H02	29,95	-	114-H02
VF 1000 F /F2 /R	SC15/SC16	84-86	115-K03	39,95	115-K03	39,95	-	-
VTR 1000 F	SC36	97-06	115-H01	29,95	115-H02	29,95	114-H01	114-H02
Varadero 1000 (ABS)	SD01 /SD02	99-	115-H01	29,95	115-H02	29,95	114-H01	114-H02
CB 1100 SF X-11	SC42	00-03	115-H01	29,95	115-H02	29,95	114-H01	114-H02
CB 1100 ABS	SC65	13-	115-H01	29,95	115-H12	29,95	114-H01	114-H12
CBR 1100 XX	SC35	97-07	115-H01	29,95	115-H02	29,95	114-H01	114-H02
VFR 1200F /FD mit DCT	SC63	10-	115-H01	29,95	115-H11	39,95	114-H01	114-H11
VFR 1200XD Crosstourer ABS	SC70C	12-13	115-H01	29,95	115-H11	39,95	114-H01	114-H11
VFR 1200XD Crosstourer ABS	SC70C	14-	115-H01	29,95	115-H13	39,95	114-H01	114-H13
CB 1300 F /S (ABS)	SC54	03-	115-H01	29,95	115-H02	29,95	114-H01	114-H02
CB-X4 1300 DC	SC38	97-99	115-H01	29,95	115-H02	29,95	114-H01	114-H02
Husqvarna								
Nuda 900 /R	A7	12-	-	-	115-B06	39,95	-	114-B06
Hyosung								
GT 650 R	GT650	all	115-HY1	29,95	-	-	-	-
Kawasaki								
Ninja 250R /SE	EX250K	08-	115-K01	29,95	115-K02	29,95	114-K01	114-K02
Ninja 300	EX300A	13-	115-K01	29,95	115-K02	29,95	114-K01	114-K02
Z 300 ABS	ER300A	15-	115-K07	29,95	115-K02	29,95	114-K07	114-K02
ZXR 400	ZX400L	all	115-K01	29,95	115-K02	29,95	114-K01	114-K02
ER-5	ER500A	97-05	115-K03	39,95	115-K04	39,95	-	-
GPZ 500S	EX500A/D	87-03	115-K03	39,95	115-K04	39,95	-	-
Zephyr 550	ZR550 B	91-	115-K01	29,95	115-K02	29,95	114-K01	114-K02
GPZ 600R	ZX600A	85-	115-K01	29,95	115-K02	29,95	114-K01	114-K02
GPX 600R	ZX600A/C	88-	115-K01	29,95	115-K02	29,95	114-K01	114-K02
ZX-6R Ninja	ZX600F /G	95-99	115-K01	29,95	115-K02	29,95	114-K01	114-K02
ZX-6R Ninja	ZX 600 J	00-01	115-K01	29,95	115-K05	29,95	114-K01	114-K05
ZX-6RR Ninja	ZX600K /K	03-05	115-K08	29,95	115-K05	29,95	114-K08	114-K05
ZX-6R Ninja	ZX 600 P/R	07-	115-K08	29,95	115-K05	29,95	114-K08	114-K05
ZX-6R 636 Ninja	ZX 636 A	02	115-K01	29,95	115-K05	29,95	114-K01	114-K05
ZX-6R 636 Ninja	ZX 636 B /C	03-06	115-K08	29,95	115-K05	29,95	114-K08	114-K05
ZX-6R 636 Ninja ABS	ZX636E	13 -	115-K08	29,95	115-K05	29,95	114-K08	114-K05
ER-6n /f (ABS)	ER /EX650A	06-08	115-K08	29,95	115-K05	29,95	114-K08	114-K05
ER-6n /f ABS	ER /EX650C /E	09-	115-K01	29,95	115-K05	29,95	114-K01	114-K05
Versys 650 (ABS)	LE 650 A /C	07-14	115-K01	29,95	115-K05	29,95	114-K01	114-K05
Versys 650 (ABS)	LE 650 E	15-	115-K07	29,95	115-K05	29,95	114-K07	114-K05
Z 650	ER650H	17-	115-K01	29,95	115-K05	39,95	114-K01	114-K05
W 650	EJ 650 A	99-	-	-	115-K04	39,95	-	-

model	type	year	foot pegs linking					
			lease order foot pegs in addition, check types on page 88					
/... = also for this model (ABS) = also for models with ABS ABS = for models with ABS only			standard				pair EUR 89,95	
			front	EUR	rear	EUR	adjustable front	rear
Kawasaki								
GPX /GPZ 750R	ZX750G /F	85-	115-K01	29,95	115-K02	29,95	114-K01	114-K02
Z 750 /S	ZR750J /L	04- /07-	115-K01	29,95	115-K05	29,95	114-K01	114-K05
Z 750R ABS	ZR750N	11-	115-K08	29,95	115-K05	29,95	114-K08	114-K05
Z 750 Turbo	ZX750E	84-	115-K01	29,95	-	-	114-K01	-
Zephyr 750	ZR750C	91-	115-K01	29,95	115-K02	29,95	114-K01	114-K02
ZR-7 /S	ZR750F	99-03	115-K01	29,95	115-K02	29,95	114-K01	114-K02
ZXR 750 /R	ZX750H /J /L	89-94	115-K01	29,95	115-K02	29,95	114-K01	114-K02
W 800	EJ800A	11-	115-K07	29,95	115-K04	39,95	114-K07	-
Z 800 ABS	ZR800A	13-	115-K08	29,95	115-K05	29,95	114-K08	114-K05
GPZ 900R	ZX900A	84-	115-K01	29,95	115-K02	29,95	114-K01	114-K02
ZX-9R Ninja	ZX900B /C	94-99	115-K01	29,95	115-K02	29,95	114-K01	114-K02
ZX-9R Ninja	ZX900E	00-03	115-K01	29,95	115-K05	29,95	114-K01	114-K05
KLV 1000	KL1000A	04-05	115-S10	29,95	115-S12	39,95	-	-
Versys 1000	LZT00A	12-	115-K07	29,95	115-K05	29,95	114-K07	114-K05
Vulcan S ABE	EN650A /D	15-16 / 17-	115-K07	29,95	-	-	-	-
Z 1000 (ABS)	ZRT00A /B	03-09	115-K01	29,95	115-K05	29,95	114-K01	114-K05
Z 1000 ABS	ZRT00D /F	10-	115-K08	29,95	115-K05	29,95	114-K08	114-K05
Z 1000SX /Tourer ABS	ZXT00G /L	11-16	115-K01	29,95	115-K05	29,95	114-K01	114-K05
Z 1000SX ABS	ZXT00W	17-	115-K01	29,95	115-K05	29,95	114-K01	114-K05
ZX-10	ZXT00B	88-	115-K01	29,95	-	29,95	114-K01	-
ZX-10 R ABS	ZXT00S	16-	115-H01	29,95	115-K05	29,95	-	-
ZX-10 R Ninja	ZXT00C /D /E /F	04-10	115-K08	29,95	115-K05	29,95	114-K08	114-K05
ZX-10 R Ninja	ZXT00J	11-	115-H01	29,95	115-K05	29,95	114-H01	114-K05
GPZ 1100 (ABS)	ZXT10E	95-98	115-K01	29,95	115-K02	29,95	114-K01	114-K02
Zephyr 1100	ZRT10A	92-98	115-K01	29,95	115-K02	29,95	114-K01	114-K02
ZRX 1100	ZRT10C	97-00	115-K01	29,95	115-K02	29,95	114-K01	114-K02
ZZR 1100	ZXT10C /D	90-	115-K01	29,95	115-K02	29,95	114-K01	114-K02
ZRX 1200 /R /S	ZRT20A	01-07	115-K01	29,95	115-K02	29,95	114-K01	114-K02
ZX-12R Ninja	ZXT20A	00-06	115-K01	29,95	115-K05	29,95	114-K01	114-K05
ZZR 1200	ZXT20C	02-	115-K01	29,95	115-K05	29,95	114-K01	114-K05
1400 GTR (ABS) (CBS)	ZGT40A /C	08-	115-K08	29,95	115-K05	29,95	114-K08	114-K05
ZZR 1400 (ABS)	ZXT40A /C /E	06-	115-K08	29,95	115-K05	29,95	114-K08	114-K05
KTM								
125 /200 /390 Duke	IS Duke C3	13-	115-T05	29,95	-	-	-	-
690 Duke 4 /R	A3	12-	115-T05	29,95	115-T05	29,95	-	-
990 Super Duke /R	LC8EFI	05-	115-S10	29,95	-	-	-	-
MV Agusta								
F4 750 /Brutale 750 /910	F4	99-05	115-D04	29,95	115-D04	29,95	114-D04	114-D04
F3 800 ABS /Brutale 800 ABS	F3 /B3	14-	115-D04	29,95	115-MV1	29,95	114-D04	-
F3 675	F3	12-	115-D04	29,95	115-MV1	29,95	114-D04	-
MZ								
MZ 1000 S /SF /SFs	MZ 1000	04-	115-MZ1	29,95	115-MZ2	29,95	-	-
Moto Guzzi								
V7 /V7 II	LW	08-	115-T05	29,95	115-A03	29,95	114-T05	-
V9 Bobber	LHA	16-	115-T05	29,95	115-A03	29,95	114-T05	-
Suzuki								
GS 500 /E /F /H	GM51B/BK /WVBK	89-	115-S04	39,95	115-S04	39,95	-	-
GSF 600 /S Bandit	GN77B /WVA8	95-04	115-S03	29,95	115-S02	29,95	114-S03	-
GSR 600	WVB 9	06-	115-H01	29,95	115-S14	29,95	114-H01	114-S14
GSX 600F	AJ	98-	115-S05	29,95	115-S05	29,95	-	-
GSX-R 600	AD	97-00	115-S01	29,95	115-S02	29,95	-	-
GSX-R 600	WVBG	01-03	115-S07	29,95	115-S02	29,95	-	-
GSX-R 600	WVB 2	04-05	115-S07	29,95	115-S08	29,95	-	-
GSX-R 600	WVCE /CV /C3	06-	115-S13	29,95	115-S14	29,95	114-S13	114-S14
RF 600R	GN76B	93-	115-S03	29,95	115-S01	29,95	114-S03	114-S03
DL 650 V-Strom (ABS)	WVB1	04-11	115-S10	29,95	115-S04	39,95	-	-
DL 650A V-Strom ABS	C7	12-	115-S10	29,95	115-S04	39,95	-	-
GSF 650 /A /S /SA Bandit (ABS)	WVB 5	05-06	115-S13	29,95	115-S09	29,95	114-S13	-
GSF 650 /S Bandit (ABS)	WVCJ /CZ	07-	115-S13	29,95	115-S14	29,95	114-S13	114-S14
GSX 650 F (ABS)	WVCJ	08-	115-S13	29,95	115-S14	29,95	114-S13	114-S14
SFV 650 Gladius (ABS)	WVCX	09-	115-S13	29,95	115-S14	29,95	114-S13	114-S14
SV 650 /S	AV	99-02	115-S01	29,95	115-S08	29,95	-	-
SV 650 /S (ABS)	WVBY	03-	115-S07	29,95	115-S08	29,95	-	-
SV 650 ABS	CX	16-	115-S13	29,95	115-S14	29,95	114-S13	114-S14
GSR 750	C5	11-	115-S13	29,95	115-S14	29,95	114-S13	114-S14
GSX 750	AE	98-01	115-S03	29,95	115-S02	29,95	114-S03	-
GSX 750 F	GR78A /AK /WVAK	89-06	115-S05	29,95	115-S05	29,95	-	-
GSX-R 750	GR75A	85-87	115-S05	29,95	115-S05	29,95	-	-
GSX-R 750	GR77B /AB /BB	88-95	115-S01	29,95	115-S01	29,95	-	-
GSX-R 750	GR7DB	96-99	115-S01	29,95	115-S02	29,95	-	-

NEW

_ REARSETS FOOD PEG LINKING

model	type	year	foot pegs linking					
			lease order foot pegs in addition, check types on page 88					
/... = also for this model (ABS) = also for models with ABS ABS = for models with ABS only			standard			pair EUR 89,95		
			front	EUR	rear	EUR	adjustable front	rear
Suzuki								
GSX-R 750	WVBD	00-03	115-S07	29,95	115-S02	29,95	-	-
GSX-R 750	WVB 3	04-05	115-S07	29,95	115-S08	29,95	-	-
GSX-R 750	WVCF /CW /C4	06-	115-S13	29,95	115-S14	29,95	114-S13	114-S14
RF 900R	GT73B	94-	115-S03	29,95	115-S03	29,95	114-S03	114-S03
V-Strom 1000	BS	02-10	115-S10	29,95	115-S12	39,95	-	-
V-Strom 1000 ABS	DD	14-	115-S10	29,95	115-S04	39,95	-	-
GSX-R 1000	WVBL	01-02	115-S07	29,95	115-S02	29,95	-	-
GSX-R 1000	WVBZ	03-04	115-S07	29,95	115-S08	29,95	-	-
GSX-R 1000	WV B6 /CL / CY	05-	115-S13	29,95	115-S14	29,95	114-S13	114-S14
GSX-S 1000 /F	DG	15-	115-S13	29,95	115-S14	29,95	114-S13	114-S14
SV 1000 /S	WVBX	03-	115-S07	29,95	115-S09	29,95	-	-
TL 1000 S /R	AG /AM	97- /98-	115-S01	29,95	115-S02	29,95	-	-
GSX-R 1100	GU74C	86-88	115-S05	29,95	115-S05	29,95	-	-
GSX-R 1100 /W	GV 73 C /75 C	89-96	115-S03	29,95	115-S03	29,95	114-S03	114-S03
GSF 1200 /S Bandit (ABS)	GV 75 A	96-00	115-S03	29,95	115-S03	29,95	114-S03	114-S03
GSF 1200 /S Bandit	WVA 9	01-05	115-S03	29,95	115-S11	29,95	114-S03	-
GSF 1200 /S Bandit (ABS)	WVCB	06	115-S13	29,95	115-S11	29,95	114-S13	-
GSX 1200 Inazuma	A3	99-	115-S01	29,95	115-S02	29,95	-	-
GSF 1250/A/S/SA/FA Bandit (ABS)	WVCH	07-	115-S13	29,95	115-S14	29,95	114-S13	114-S14
GSX 1300 BK B-King (ABS)	WVCR	08-	115-S10	29,95	115-S14	29,95	-	114-S14
GSX 1300 R Hayabusa	WVA 1	99-07	115-S13	29,95	115-S02	29,95	114-S13	-
GSX 1300 R Hayabusa II	WVCK	08-	115-S13	29,95	115-S14	29,95	114-S13	114-S14
GSX 1400	WVBN	02-	115-S07	29,95	115-S12	39,95	-	-
Triumph								
Daytona 600	806 LW	04-	115-T08	29,95	115-T06	29,95	-	-
Speed Four	806 LB	02-	115-T01	29,95	115-T06	29,95	114-T01	-
TT 600	806 AD	00-	115-T01	29,95	115-T06	29,95	114-T01	-
Daytona 650	865 LX	05	115-T08	29,95	115-T06	29,95	-	-
Daytona 675 /R (ABS)	D67LC /H67	06-	115-T13	29,95	115-T12	29,95	-	-
Street Twin	DP01	16-	115-T13	29,95	115-T12	29,95	114-T13	-
Street Triple /R	D67LD /L67LR	08-	115-T13	29,95	115-T12	29,95	-	-
America	908M	02-	115-T14	39,95	115-T15	39,95	-	-
Bonneville*	908 MD	02-06	115-T14	39,95	115-T15	39,95	-	-
America	908MK /908MK2	07-	115-T14	39,95	115-T15	39,95	-	-
NEW Bonneville T100	DB01	17-	115-T16	39,95	115-T12	39,95	114-T16	-
Bonneville* /T100*	986 MF	07- /05-15	115-T14	39,95	115-T15	39,95	-	-
Bonneville T120	DU01/1/1	16-	115-T16	29,95	115-T12	29,95	114-T16	-
NEW Street Cup	DZ01	17-	115-T13	29,95	115-T12	29,95	114-T13	-
Scrambler*	986MG /2	06-15	115-T14	39,95	115-T15	39,95	-	-
NEW Thruxton 900	986ME /2	05-15	115-T09	29,95	115-T10	29,95	-	-
Thruxton 1200 /R	DE01/1/2 /1	16-	115-T13	29,95	115T072RSW	79,95	114-T13	-
Daytona 900 /Super III	T300 /B /D	93-96	115-T01	29,95	115-T01	29,95	114-T01	114-T01
Speed Triple 900	T300B	94-96	115-T01	29,95	115-T01	29,95	114-T01	114-T01
Sprint 900 /Executive /Sport	T300A	93-98	115-T01	29,95	115-T01	29,95	114-T01	114-T01
Thunderbird /Sport	T309RT /309RT	95-04	115-T15	39,95	115-T15	39,95	-	-
Daytona T595 /955i /Century Edition	T595 /595N	97-05	115-T05	29,95	115-T06	29,95	114-T05	-
Speed Triple /T509	T509/595RPT/595N	97-04	115-T05	29,95	115-T06	29,95	114-T05	-
Sprint RS /ST	T695 /AC / AB	00-04	115-T01	29,95	115-T06	29,95	114-T01	-
Tiger	T709 /709EN	99-06	115-T01	29,95	115-T01	29,95	114-T01	114-T01
Speed Triple	515 NJ	05-11	115-T05	29,95	115-T11	29,95	114-T05	-
Speed Triple (ABS)	515 NV	11-	115-T13	29,95	115-T12	29,95	-	-
Tiger 1050 (ABS)	115 NG	07-	115-T05	29,95	115-T11	29,95	114-T05	-
Tiger 1050 Sport ABS	115 NG	13-	115-T13	29,95	115-T11	29,95	114-T13	114-T13
Daytona 1200	T300/D	93-	115-T01	29,95	115-T01	29,95	114-T01	114-T01
Yamaha								
YZF-R 125	RE06	08-	115-Y01	29,95	115-Y02	29,95	114-Y01	114-Y02
YZF-R 3	RH07	15-	115-HY1	29,95	115-Y02	29,95	-	114-Y02
SR 400	RH05	10-	115-Y01	29,95	115-Y02	29,95	-	-
XJR 400	4HM	90-07	115-Y01	29,95	115-Y02	29,95	114-Y01	114-Y02
XV 535 Virago	all	87-	115-Y05	29,95	115-Y06	29,95	-	-
FZ 6 Fazer /S (ABS)	RJ 07	04-06	115-Y01	29,95	115-Y02	29,95	114-Y01	114-Y02
FZ 6 /Fazer /S2 (ABS)	RJ 14	07-	115-Y01	29,95	115-Y09	29,95	114-Y01	-
FZR 600 Genesis /R Genesis	Alle	89-95	115-Y01	29,95	115-Y02	29,95	114-Y01	114-Y02
FZS 600 Fazer	RJ02	98-03	115-Y01	29,95	115-Y02	29,95	114-Y01	114-Y02
SRX 600	all	86-	115-Y01	29,95	115-Y02	29,95	114-Y01	114-Y02
XJ 600 N /S /F /Diversio	4BR /4LX /R/J01	92-03	115-Y01	29,95	115-Y02	29,95	114-Y01	114-Y02
XJ 6 /Diversio /F (ABS)	RJ 19	09-	115-Y01	29,95	115-Y02	29,95	114-Y01	114-Y02
YZF 600R Thundercat	4TV/4WD	96-	115-Y01	29,95	115-Y02	29,95	114-Y01	114-Y02
YZF-R 6	RJ 03	99-02	115-Y01	29,95	115-Y02	29,95	114-Y01	114-Y02
YZF-R 6 /S	RJ05 /09/95/11/15	03-	115-Y11	29,95	115-Y10	29,95	-	-

model	type	year	foot pegs linking					
			lease order foot pegs in addition, check types on page 88					
/... = also for this model (ABS) = also for models with ABS ABS = for models with ABS only			standard				pair EUR 89,95	
			front	EUR	rear	EUR	adjustable front	rear
Yamaha								
XVS 650 Drag Star	all	97-	115-Y05	29,95	-	-	-	-
MT-03	RM02	06-	115-Y01	29,95	115-Y02	29,95	114-Y01	114-Y02
SZR 660	4SU	95-	115-Y01	29,95	115-Y02	29,95	114-Y01	114-Y02
MT-07	RM041	14-	115-Y01	29,95	115-Y02	29,95	114-Y01	114-Y02
XSR 700 ABS /900 ABS	RM11 / RN431	15- /16-	115-Y01	29,95	115-Y02	29,95	114-Y01	114-Y02
FZ 750 /Genesis	all	85-	115-Y01	29,95	115-Y02	29,95	114-Y01	114-Y02
FZX 750	2JE	87-	115-Y01	29,95	-	-	114-Y01	-
XV 750 Virago /SP	4FY /4PW	92-97	115-Y05	29,95	115-Y06	29,95	-	-
YZF 750 R	all	93-	115-Y01	29,95	115-Y02	29,95	114-Y01	114-Y02
YZF 750 SP	4HT	93-	115-Y01	29,95	-	-	114-Y01	-
FZ 8 /Fazer 8 (ABS)	RN 25	10-	115-Y01	29,95	115-Y02	29,95	114-Y01	114-Y02
TRX 850	4 UN	96-	115-Y01	29,95	115-Y02	29,95	114-Y01	114-Y02
TDM 850	3VD	91-98	115-Y01	29,95	115-Y02	29,95	-	-
MT-09 /Tracer	RN29	13- /15-	115-Y01	29,95	115-Y02	29,95	114-Y01	114-Y02
TDM 900 (ABS)	RN 08 /11 /18	2-3/4-6/07-	115-Y01	29,95	115-Y09	29,95	114-Y01	-
XJ 900 Diversion	4KM	95-03	115-Y01	29,95	115-Y02	29,95	114-Y01	114-Y02
XV 950 ABS	VN03	14-	s. Extreme foot peg p. 90		115-Y13	39,95	-	-
FZ 1 /Fazer (ABS)	RN16	06-	115-Y01	29,95	115-Y02	29,95	114-Y01	114-Y02
FZR 1000 Genesis /EXUP	2LA /3LE	87-95	115-Y01	29,95	115-Y02	29,95	114-Y01	114-Y02
FZS 1000 Fazer	RN06 /14	01-05	115-Y01	29,95	115-Y09	29,95	114-Y01	-
YZF 1000 Thunderace	4VD /4SV	96-01	115-Y01	29,95	115-Y02	29,95	114-Y01	114-Y02
YZF-R 1	RN 01	98-99	115-Y01	29,95	115-Y02	29,95	114-Y01	114-Y02
YZF-R 1	RN 04	00-01	115-Y07	29,95	115-Y08	29,95	-	-
YZF-R 1	RN 09	02-03	115-Y07	29,95	115-Y10	29,95	-	-
YZF-R 1 /SP /M	RN12/19/22/32	04-	115-Y11	29,95	115-Y10	29,95	-	-
MT 10	RN451	16-	115-Y01	29,95	115-Y02	29,95	114-Y01	114-Y02
BT 1100 Bulldog (NSR 1100)	RP 05	02-07	115-Y01	29,95	115-Y09	29,95	114-Y01	-
VMX 1200	all	-04	115-Y05	29,95	115-Y06	29,95	-	-
XJR 1200 /SP	4 PU	96-99	115-Y01	29,95	115-Y02	29,95	114-Y01	114-Y02
XT 1200Z Super Ténéré	DP01	12-	-	-	115-Y02	29,95	-	114-Y02
XJR 1300	RP02 /06 /10 /19	99-	115-Y01	29,95	115-Y02	29,95	114-Y01	114-Y02
FJR 1300 /A /AS	RP 04 /08 /11 /13	01-	115-Y01	29,95	115-Y09	29,95	114-Y01	-
MT-01 /S	RP12 /18	05-	115-Y01	29,95	-	-	114-Y01	-
V-Max 1700	RP 21	09-	115-Y01	29,95	115-Y10	29,95	114-Y01	-

* allso see page 81 for Extreme foot peg kits: app. 2 cm more ground clearance + protection against little falls



STEERING DAMPER

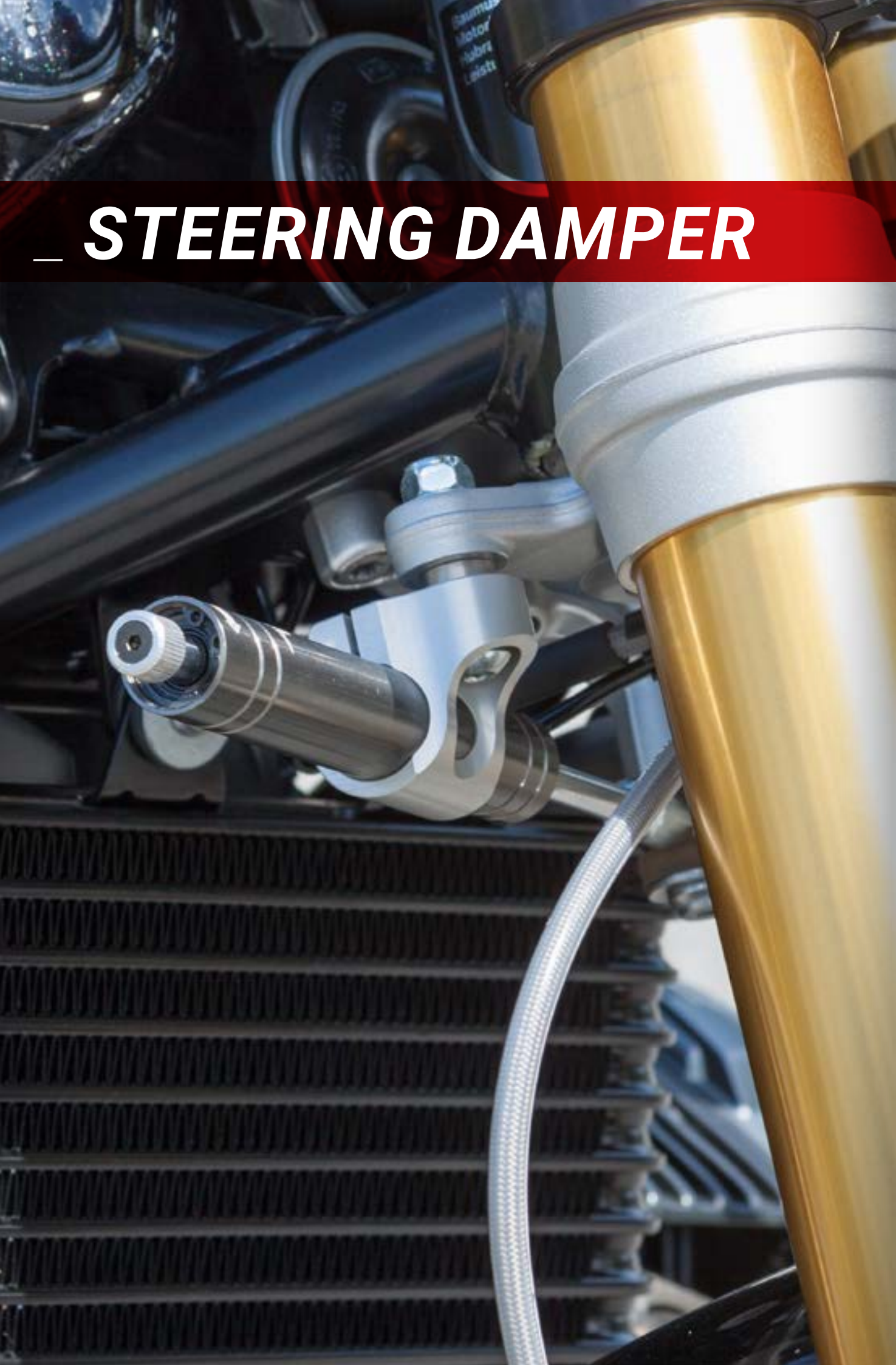



THE LSL **STEERING DAMPER**

The steering damper is an effective and tested application to prevent kick-back and frequency shimmy at the front fork.

While extremely tightly tuned damping elements are used in racing, LSL offers a little progressive steering damper, which is particularly suitable for road traffic. LSL relies on the 30 years of experience with a damper element, which is meticulously assembled in Japan in small series by precise employees. The proverbial reliability confirms the high quality of this steering damper.

The damper unit is well proven for stability and safety. It consists of a stiff aluminum housing containing a 7 setting adjustable hydraulic damping system. Different kinds of damper brackets meet different requirements for the mounting position.

Performance steering damper

- _ Alu housing, machined body brackets
- _ 7 adjustable setting, 6 different lengths
- _ Model specific mounting kits

LSL PERFORMANCE



Team Bolliger and NRT 48

24h Le Mans 2015 © F. Foadelli

_ STEERING DAMPER KITS

MODEL SPECIFIC STEERING DAMPER KITS			in cockpit	across to fuel tank	aside the frame	at engine	at original mountings	steering stop	T	O				
model	type	year							version titan	version oval	item no	EUR	item no	EUR
BMW														
F800S /ST /R	E8ST	06-							•		100B032T	239,00	-	-
S 1000RR	K10	09-							•		100B040T	239,00	-	-
R 850/1100R	259	94-							•		100B027T	229,00	-	-
R 1100S	R2S	all							•		100B027T	229,00	-	-
R nineT	R1ST	14-							•		100B049T	229,00	-	-
R nineT Scrambler	1N12	16-							•		100B056T	229,00	-	-
R 1200R	R1ST	11-							•		100B046T	249,00	-	-
R 1200R /RS	R12WR/0A04/4	15-							•		100B053T	229,00	-	-
R 1200S	R12S	06-							•		100B030T	229,00	-	-
Buell														
M2/S1/X1		all							•		100BU01T	279,00	-	-
X1		all							•		100BU03T	279,00	-	-
XB-Modelle	XB1	02-04							•		100BU05T	349,00	-	-
XB-Modelle	XB1	05-							•		100BU07T	349,00	-	-
Ducati														
Monster 750 /900	M100AA/900M	93-01							•		100D015T	279,00	-	-
Monster 696 /1100	M5	08-							•		100D036T	279,00	-	-
Monster S4	M400/A	01-							•		100D023T	279,00	-	-
748R /S /SP	748/H3	96-							•		100D016T	229,00	-	-
748 /916 /996 /998	916/H2	95-							•		100D016T	229,00	-	-
848	H6	08-10							•		100D042T	279,00	-	-
Streetfighter /S	F1	09-							•		100D037T	259,00	-	-
Harley-Davidson														
Sportster	XL2	04-							•		100HD19T	339,00	-	-
Honda														
CBR 600 F	PC35	99-06							•		100H086T	279,00	-	-
CBR 900RR	SC28 / SC33	92-93 / 94-97							•		100H047T	279,00	-	-
CBR 900RR	SC44	00-01							•		100H090T	309,00	-	-
CBR 900RR	SC50	02-03							•		100H100T	339,00	-	-
Hornet 900	SC48	all							•		100H097T	339,00	-	-
VTR 1000	SC36	all							•		100H075T	309,00	-	-
Kawasaki														
ZX-6R	ZX600P	07-08							•		100K120T	339,00	-	-
ZX-6RR	ZX600K	03-04							•		100K101T	359,00	-	-
ZX-6R 636 ABS	ZX636E	13-							•		100K146T	329,00	-	-
ZX-10R	ZXT00C	04-05							•		100K105T	359,00	-	-
KTM														
Superduke 990	LC8EFI	05-06							•		100KT07T	309,00	-	-
Superduke 990	LC8EFI	07-							•		100KT08T	309,00	-	-
Suzuki														
GSX-R 600	JS1BG	01-03							•		100S087T	309,00	-	-
GSX-R 600	B2	04-05							•		100S082T	259,00	-	-
GSX-R 600	CE	06-07							•		100S108T	259,00	-	-
GSX-R 750	GR7AB/BB	90-93							•		-	-	100S044	279,00
GSX-R 750	BD/ B3	00-05							•		100S082T	259,00	-	-
GSX-R 750	CF	06-07							•		100S108T	259,00	-	-
GSX-R 1000	BL/ BZ	01-04							•		100S082T	259,00	-	-
GSX-R 1000	B6	05-06							•		100S099T	229,00	-	-
TL 1000R	JS1AM	all							•		100S072T	219,00	-	-
SV 1000S / 100N	JS1BX / WVBX	03- / 03-05							•		100S093T	229,00	-	-
B-King (ohne ABS)	WVCR	08-							•		100S119T	229,00	-	-
GSX 1300 Hayabusa	A1	99-07							•		100S077T	229,00	-	-
GSX 1300R Hayabusa	WVCK	08-12							•		100S120T	229,00	-	-
Triumph														
Daytona T595/955i	T595	96-01							•		100T014T	329,00	-	-
Daytona T955i	595N	02-03							•		100T025T	329,00	-	-
Street Triple 675 /R*	D67LD	08-12							•		100T041T	329,00	-	-
Street Triple 675 /R	L67LR	13-							•		100T053T	339,00	-	-
Bonneville**/ Thruxton**	986M	-15							•		100T024T	279,00	-	-
Thruxton	DE01/1/2	16-							•		100T072T	in prep.	-	-
Speed Triple 1050	515N	05-10							•		100T033T	329,00	-	-
Yamaha														
YZF-R6	RJ03	99-02							•		100Y079T	359,00	-	-
YZF-R6	RJ051/91/95	03-05							•		100Y089T	359,00	-	-
YZF-R6	RJ11/15	06-07 /08-							•		100Y118T	379,00	-	-
YZF-R1	RN01/04	98-01							•		100Y077T	279,00	-	-
YZF-R1	RN09	02-03							•		100Y088T	359,00	-	-
YZF-R1	RN12	04-05							•		100Y094T	229,00	-	-
YZF-R1	RN12/19	06-							•		100Y108T	229,00	-	-
XJR 1200/1300	4PU/ RP02/RP06/RP10	all							•		100Y090T	279,00	-	-

* model R with LSL X-Bar clamps 127X080 only

** need new headlight brackets and relocation the ignition lock

MOUNTING POSSIBILITIES

The mounting of these parts is demanding and should be done only by a trained mechanic.



mounting across the fuel tank
Not possible with SB-Kit



mounting at the frame



mounting like original one



mounting BMW at semi-trailing

VERSION TITAN

the compact racing version

damper: round, titan anodised; 7 settings; rod: 8 mm;
clamp: milled with ball joint in 3 different versions or as alloy
clamp with ball joint



T

VERSION OVAL

noble done for naked and classic bikes

damper: oval, silver anodised; 7 settings; rod: 9 mm;
clamp: aluminum clamp with ball joint



O

product	stroke	length of housing	total length	T titan item no	EUR	O oval item no	EUR
steering damper unit							
damper element	62 mm	140 mm	250 mm	101TI06	209,00	-	-
damper element	70 mm	145 mm	285 mm	101TI07	209,00	101OV07	199,00
damper element	100 mm	174 mm	335 mm	101TI10	219,00	-	-
damper element	120 mm	194 mm	375 mm	101TI12	229,00	101OV12	219,00
damper element	135 mm	209 mm	405 mm	101TI14	239,00	-	-
damper element	150 mm	224 mm	435 mm	-	-	101OV15	239,00
repair kit							
dampers piston, shimmings, oil seals				101-R22.3	29,95	101-R24.5	29,95
dampers Piston for 70mm damper (hard), shimmings, oil seals				101-R22.3H	25,95	-	-

clamp size	standard 34,95 EUR/Stk	X	long 34,95 EUR/Stk.	X	extra long 45,95 EUR/Stk.	X
------------	------------------------	---	---------------------	---	---------------------------	---

stanchion clamps						
32 mm	103B032	23 mm	-	-	-	-
35 mm	103B035	24 mm	-	-	-	-
36 mm	103B036	24 mm	-	-	-	-
37 mm	103B037	23 mm	-	-	-	-
38 mm	103B038	23 mm	-	-	-	-
39 mm	103B039	17 mm	103B039L	28 mm	-	-
40 mm	103B040	17 mm	-	-	-	-
41 mm	103B041	16 mm	103B041L	23 mm	-	-
42 mm	103B042	16 mm	-	-	-	-
43 mm	103B043	15 mm	-	-	103B043XL	61 mm
45 mm	103B045	15 mm	103B045L	24 mm	103B045XL	51 mm
46 mm	103B046	16 mm	-	-	-	-
48 mm	103B048	17 mm	-	-	-	-
49 mm	103B049	17 mm	-	-	103B049XL	60 mm
50 mm	103B050	16 mm	103B050L	29 mm	-	-
51 mm	103B051	16 mm	-	-	-	-
52 mm	103B052	16 mm	-	-	-	-
53vmm	103B053	17 mm	103B053L	28 mm	-	-
54 mm	103B054	17 mm	103B054L	27 mm	103B054XL	47 mm
55 mm	103B055	16 mm	-	-	-	-
56 mm	103B056	16 mm	-	-	103B056XL	46 mm

STANCHION CLAMPS

These milled aluminum clamps are made to mount accessory parts on the stanchions. Different diameters and lengths are available. The distance from the front of the stanchion to middle of threaded drilling (M8) is shown as „X“ in the table.



standard

long

extra long

_ PROTECTORS





CRASH PAD® - PROTECTORS WITH LEADERSHIP QUALITIES

o minimize damage, the elegant impact insert of the crash pad is equipped with a suspension mechanism.

Through a constructive trick the intelligent calculated impact-pad is subdued, thus relieving bracket and screw construction. This feature protects the motorcycle on the fastening points of the Crash Pads effective area from damage.

The inner part is made of plastic as an elongated skid, so that the guide function could be improved. It absorbs in case of a fall the impact and reduces the speed of the leaderless vehicle. In case of a light slid it is usually sufficient only to replace the inner part.

The aluminum outer shell is made from the solid and the surface is coated glossy. The rounded contour of the crash pad head absorbs pavement cracks; a hooking of the vehicle into road stages (manhole covers, etc.) is effectively prevented. Due to the high proportion of plastic, the weight of the outer shell could be kept low.

The crash pads are available with solid mounting kits for different models; please see description for detailed versions.

Uli Bonsels, Customer Service Manager Triumph, comment to his fall during Street Triple Cup in Hockenheim

„Thanks to your great crash pads my motorbike was, we can hardly believe it, almost intact and I was able to rejoin the race immediately. The engine crash pads, front and rear axles, the bar end weights and the footrests have done a great job and kept all damage away from the bike. That’s how it should be!“

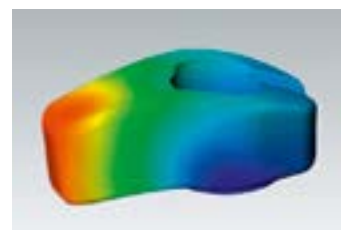
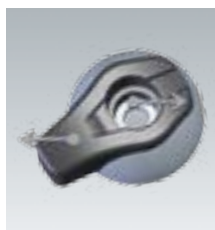

The offset from the center service generates a strong return torque that keeps the vehicle skidding in the direction. The computer simulation is used as a basis for calculating the force curve in case of a fall. Fall experiences from many years confirm this function.

_ PROTECTORS **CRASH PADS®**

CRASH PAD® AS SKID PAD

Do you like it understated or do you watch the weight? Use the new Skid Pad. It makes it possible to mount the slider without the alu part. The kit comes with all required mounting parts.

These kits are specially marked with a **SP** in the list.

SP



553 ...

ORDER INSTRUCTIONS **CRASH PAD®**

! Crash Pad® heads **+** model specific mounting brackets

CRASH PAD® SELECT HEAD



550-002..



550-002PT



554-SP2-L

CRASH PAD®

plastic insert and aluminum shell, choose mounting kit and order!

CRASH PAD® PLASTIC

complete plastic, choose mounting kit and order!

CRASH PAD® INSERT

is available separately, left and right differs in the position of the LOGO imprint.

COLOUR

Crash Pad colour	surface	order info
black	anodised	item no .. SW
titan	anodised	item no .. TI
silver	anodised	item no .. SI
gold	anodised	item no .. GO
yellow	powder coated	item no .. GE
orange	powder coated	item no .. OR
signal red	powder coated	item no .. SR
green	powder coated	item no .. GR
white	powder coated	item no .. WT
transp. red	transp. coated	item no .. RT
transp. blue	transp. coated	item no .. BL
chrome	chromed	item no .. CR
carbon look	dip-coated	item no .. CA

material	colour	surface	item no	EUR
Crash Pad head				pair
aluminium	black	anodised	550-002SW	49,95
aluminium	titan	anodised	550-002TI	49,95
aluminium	silver	anodised	550-002SI	49,95
aluminium	gold	anodised	550-002GO	49,95
aluminium	yellow	pulverbeschichtet	550-002GE	49,95
aluminium	orange	pulverbeschichtet	550-002OR	49,95
aluminium	signal red	pulverbeschichtet	550-002SR	49,95
aluminium	green	pulverbeschichtet	550-002GR	49,95
aluminium	white	pulverbeschichtet	550-002WT	49,95
aluminium	transp. red	lasurbeschichtet	550-002RT	49,95
aluminium	transp. blue	lasurbeschichtet	550-002BL	49,95
aluminium	carbon look	tauchbeschichtet	550-002CA	49,95
aluminium	chrome	chromed	550-002CR	69,95
plastic	matt black		550-002PT	35,95
Crash Pad insert (also for Skid Pad)				p/pc
plastic	black	right Seite	554-SP2-R	6,95
plastic	black	left Seite	554-SP2-L	6,95

CRASH PAD® MODEL SPECIFIC MOUNTING BRACKETS

Depending on model, different mounting sets are available (model specific).

DS, direct screwed with the engine bolts.

RA, screwing with adapter plates on the frame.

MA, screwed with adapter plates across the engine cover.



model	type	year	directly screwed DS: directly screwed at engine bolts SP: Skid Pad, fastening same as DS L/R: left and/or right the fairing has to be drilled SW: kit is also available in black, please complete the item no with „SW“				screwed with adapter plate MA: across engine cover RA: with engine bolts at the frame				
Aprilia											
Shiver 750	RA	08-	DS	-	550A019	-	35,95	-	-	-	-
Dorsoduro	SM	08-	DS	-	550A019	-	35,95	-	-	-	-
RSV1000 /Tuono	RR	06-	-	-	-	-	-	MA	L/R	550A015.1	89,95
RSV 4	RK	10-	-	-	-	-	-	RA	-	550A022.1	119,95
Tuono V4R	RK	11-14	-	-	-	-	-	RA	-	550A022.1	119,95
Tuono V4 1100 Factory	TY	15-	-	-	-	-	-	RA	-	550A022.1	119,95
Benelli											
TNT 1130	TN	all	-	-	-	-	-	RA	-	550BE01	89,95
BMW											
F 700 GS	E8GS	13-	DS	L/R	550B048	-	49,95	-	-	-	-
F 800S	E8ST	06-	-	-	-	-	-	RA	-	550B032	79,95
F 800R	E8ST	09-14	-	-	-	-	-	RA	-	550B032	79,95
F 800R	E8ST	15-	-	-	-	-	-	RA	-	550B054	89,95
F 800ST	E8ST	06-	-	-	-	-	-	RA	L/R	550B035	79,95
S1000 RR	K46	09-11	DS	-	550B040	SW	35,95	-	-	-	-
S1000 RR	K46	12-14	DS	R	550B040	SW	35,95	-	-	-	-
S1000 RR	K46	09-14	SP	R	553B040	SW	54,95	-	-	-	-
S1000 RR	K10	15-	SP	R	553B051	-	54,95	-	-	-	-
K1200R	K12R	05-	DS	-	550B029	-	29,95	-	-	-	-
Buell											
XB-9R /S /12R /S	4MZAX	all	-	-	-	-	-	MA	-	550BU04	149,95
Cagiva											
Raptor 1000	M200AAY	all	DS	-	550C003	-	35,95	-	-	-	-
Ducati											
Monster 600	ZDM600M	all	DS	-	550D018	-	35,95	-	-	-	-
Monster 696	M5	08-	DS	-	550D036	-	59,95	-	-	-	-
Monster 900	900M /A	-01	DS	-	550D015	-	59,95	-	-	-	-
Monster 900/1000	M2 /M4	02-	DS	-	550D023	-	59,95	-	-	-	-
Monster S4 /S2R /S4R	M400A	all	DS	-	550D030	-	59,95	-	-	-	-
Monster 1100	M5	09-	DS	-	550D036	-	59,95	-	-	-	-
Hypermotard 1100	B1	09-	DS	-	550D023	-	59,95	-	-	-	-
Multistrada 1200	A2	10-	DS	-	550D037	-	59,95	-	-	-	-
Streetfighter 1098 /848	F1	09-/12-	DS	-	550D037	-	59,95	-	-	-	-
Monster 821 /1200 /S	M6	14-	-	-	-	-	-	-	-	550D048.1SW	109,95
Honda											
CBR 125	JC39	07-10	-	-	-	-	-	RA	-	550H120	79,95
CBF 500	PC39	04-	DS	-	550H102	-	45,95	-	-	-	-
CBR 500RA	PC44	13-15	-	-	-	-	-	MA	-	550H142.1	89,95
CB 500FA	PC45	13-	DS	-	550H143	-	42,95	MA	-	550H142.1	89,95

_ PROTECTORS CRASH PADS®

model	type	year	directly screwed				screwed with adapter plate				
			DS: directly screwed at engine bolts SP: Skid Pad, fastening same as DS				MA: across engine cover RA: with engine bolts at the frame				
			L/R: left and/or right the fairing has to be drilled SW: kit is also available in black, please complete the item no with „SW“								
Honda											
Hornet 600	PC34 /36	98-06	DS	-	550H080	-	29,95	-	-	-	-
Hornet 600	PC41	07-/11-	DS	-	550H118	-	35,95	MA	-	550H140.1	- 89,95
CBF 600	PC38	05-07	DS	-	550H080	-	29,95	-	-	-	-
CBF 600 /N /S	PC43	08-	DS	-	550H122	-	35,95	-	-	-	-
CBR 600F	PC25 /31	91-95	DS	L/R	550H046	-	29,95	-	-	-	-
CBR 600F	PC35	99-06	DS	L/R	550H086	-	29,95	-	-	-	-
CBR 600F	PC41	11-	DS	L/R	550H137	-	35,95	MA	-	550H140.1	- 89,95
CBR 600RR	PC37B	03-06	DS	L/R	550H099	-	35,95	-	-	-	-
CBR 600RR	PC40	07-08	DS	L/R	550H117	-	35,95	MA	-	550H117.1	- 79,95
CBR 600RR /ABS	PC40	09-	DS	L/R	550H132	-	35,95	-	-	-	-
CB 650F	RC75	14-	-	-	-	-	-	RA	-	550H155.1	- 89,95
CBR 650	RC74	14-	-	-	-	-	-	RA	L/R	550H156.1	- 119,95
NC 700 S / X	RC61 /63	12-13	-	-	-	-	-	MA	-	550H138.1	- 89,95
NC 750 X / XD /S	RC72 /70/90	14-	-	-	-	-	-	MA	-	550H138.1	- 89,95
VFR 800X Crossrunner ABS	RC80	15-	-	-	-	-	-	MA	-	550H159.1	- 129,00
Hornet 900	SC48	all	-	-	-	-	-	MA	-	550H097	- 89,95
CBR 900RR	SC28 /SC33	92-99	DS	L/R	550H047	-	29,95	-	-	-	-
CBR 900RR	SC44 /SC50	00-03	DS	-	550H090	-	29,95	-	-	-	-
CBF 1000	SC58	06-09	DS	-	550H111	-	35,95	-	-	-	-
CBF 1000F	SC64	10-	DS	-	550H127	-	35,95	-	-	-	-
CB 1000R	SC60	08-	DS	-	550H127	-	35,95	-	-	-	-
CBR 1000RR	SC57	04-05	-	-	-	-	-	RA	-	550H103	- 89,95
CBR 1000RR	SC57	06-07	-	-	-	-	-	RA	-	550H114	- 89,95
CBR 1000RR	SC59	08-	-	-	-	-	-	MA	-	550H125.1	- 139,95
CBR 1000RR ABS	SC59	09-	-	-	-	-	-	MA	-	550H131.1	- 139,95
VTR 1000F	SC36	all	-	-	-	-	-	RA	-	550H075	- 99,95
VTR 1000-SP1	SC45A	all	DS	L/R	550H093	-	49,95	-	-	-	-
X11	SC42	all	DS	-	550H091	-	35,95	-	-	-	-
CBR 1100XX	SC35	all	DS	L/R	550H074	-	29,95	-	-	-	-
CB 1100	SC65	13-	-	-	-	-	-	RA	-	550H141.1	- 89,95
VFR 1200	SC63A	10-	-	-	-	-	-	MA	-	550H133.1	- 169,95
CB 1300	SC54	all	-	-	-	-	-	MA	-	550H101	- 99,95
Hyosung											
GT 650/S	KM4	05-	DS	L/R	550HY01	-	75,95	-	-	-	-
Husqvarna											
Nuda 900	A7/00/A	12-	DS	-	550HU02	-	35,95	-	-	-	-
Kawasaki											
Ninja 250R	EX250-K	08-	-	-	-	-	-	RA	-	550K132.1	- 89,95
Z300 ABS	ER300A	15-	-	-	-	-	-	-	-	550K149.1	- 99,95
Ninja 300R	EX300A	13-	-	-	-	-	-	RA	L/R	550K145.1	- 109,95
ZXR-400	ZX400L	all	DS	-	550K053	-	29,95	-	-	-	-
ZX-6R	ZX600J/ZX636A	00-02	DS	L/R	550K098	-	75,95	-	-	-	-
ZX-6R/RR	ZX636B/ZX600K	03-04	DS	-	550K101	-	29,95	-	-	-	-
ZX-6R/RR	ZX636C/ZX600N	05-06	DS	L	550K107	-	29,95	RA	-	550K107.1	- 49,95
ZX-6R	ZX600P	07-08	-	-	-	-	-	RA	-	550K120.1	- 79,95
ZX-6R	ZX600R	09-13	DS	L/R	550K131	-	29,95	RA	-	550K131.1	- 75,95
ZX-6R 636	ZX636E	13-	DS	-	550K146	-	29,95	RA	-	550K146.1	- 99,95
ER-6n	ER650A	05-08	-	-	-	-	-	RA	-	550K113	- 69,95
ER-6f	EX650A	06-08	-	-	-	-	-	RA	L/R	550K117	- 69,95
ER-6n	ER650C	09-11	-	-	-	-	-	RA	-	550K133	- 75,95
ER-6F	ER650C	09-11	-	-	-	-	-	RA	L/R	550K134	- 75,95
ER-6n /f	ER650E	12-	-	-	-	-	-	-	-	550K140.1	- 79,95
Versys 650	LE650A /C	07-14	-	-	-	-	-	RA	-	550K113	- 69,95
Versys 650	LE650E	15-	DS	-	550K148	-	39,95	-	-	-	-
Z 650	Z650H	17-	DS	-	550K155SW	-	in prep.	-	-	-	-
Z 750	ZR750J	04-06	-	-	-	-	-	MA	-	550K104	- 69,95
Z 750	ZR750L	07-	-	-	-	-	-	RA	-	550K124	- 75,95
Z 750R	Z750R	11-	-	-	-	-	-	RA	-	550K124	- 75,95
Z 800	ZR800A	13-	-	-	-	-	-	-	-	550K144.1	SW 79,95
ZX-9R	ZX900E	00-01	DS	L/R	550K091	-	69,95	-	-	-	-
ZX-9R	ZX900EF	02-03	DS	-	550K099	-	29,95	-	-	-	-
Z 1000	ZRT00A	03-06	DS	-	550K102	-	35,95	MA	-	550K104	- 69,95
Z 1000	ZRT00B	07-09	-	-	-	-	-	RA	-	550K124	- 75,95
Z 1000	ZRT00D	10-	DS	-	550K135	-	29,95	RA	-	550K135.1	- 99,95
Z 1000	ZRT00F	14-	DS	-	550K135	-	29,95	RA	-	550K135.1	- 99,95
Z 1000SX	ZXT00W	17-	-	-	-	-	-	RA	-	550K158.1	SW in prep.
Z 1000SX	ZXT00G	11-16	DS	L/R	550K138	-	35,95	RA	-	550K138.1	SW 109,95
Versys 1000	LZT00A/A/1	12-14	DS	-	550K143	-	34,95	-	-	-	-
Versys 1000 ABS	LZT00B	15-	-	-	-	-	-	RA	-	550K150.1	- in prep.
ZX-10R	ZXT00C	04-05	-	-	-	-	-	RA	L/R	550K105	- 79,95

model	type	year	directly screwed				screwed with adapter plate					
			DS: directly screwed at engine bolts SP: Skid Pad, fastening same as DS				MA: across engine cover RA: with engine bolts at the frame					
			L/R: left and/or right the fairing has to be drilled SW: kit is also available in black, please complete the item no with „SW“									
Kawasaki												
ZX-10R	ZXT00D	06-07	-	-	-	-	-	RA	-	550K114	-	99,95
ZX-10R	ZRT00E	08-10	DS	L	550K127	-	29,95	RA	L	550K127.1	-	89,95
ZX-10R / ABS	ZRT00J / ZRT00S	11- / 16-	DS	-	550K136	-	29,95	RA	-	550K136.1	-	79,95
ZRX 1100	ZRT10C	all	-	-	-	-	-	MA	-	550K096	-	65,95
ZRX 1200	ZRT20A	all	-	-	-	-	-	MA	-	550K096	-	65,95
ZZR 1200	ZXT20C	all	-	-	-	-	-	RA	-	550K100	-	69,95
ZZR 1400	ZXT40A	06-11	-	-	-	-	-	RA	-	550K115	-	99,95
KTM												
125 / 200 Duke	IS Duke C3	11-	-	-	550KT17	-	59,95	-	-	-	-	-
390 Duke	IS Duke C3	11-	-	-	550KT16	-	59,95	-	-	-	-	-
990 SuperDuke	VD	05-	-	-	-	-	-	RA	-	550KT07.1	SW	99,95
950 Supermoto/ R		06-	-	-	-	-	-	RA	-	550KT07.1	SW	99,95
990 SMT		-13	-	-	-	-	-	RA	-	550KT10.1	SW	99,95
1290 Super Duke R		14-	-	-	-	-	-	RA	-	550KT15.1SW		129,95
Moto Morini												
Corsaro 1200 / Scrambler 1200		all	DS	-	550MM01	-	59,95	-	-	-	-	-
MV Agusta												
F4 Brutale 750/ 910 S		-09	DS	-	550MV03	-	35,95	-	-	-	-	-
Brutale 800 /ABS		13-	DS	-	550MV08	-	59,95	-	-	-	-	-
Suzuki												
GSF 600	GN77B/JS1A8	95-04	DS	-	550S064	-	69,95	RA/MA	-	550S064.1	-	69,95
GSX-R 600V	JS1AD/BG	97-03	DS	L	550S082	-	29,95	-	-	-	-	-
GSX-R 600	JS1B2/JS1B3	04-05	DS	-	550S094	-	29,95	RA	-	550S097.1	-	75,95
GSX-R 600	WVCE/ WVCV	06-10	DS	L	550S108	-	29,95	MA	-	550S108.1	-	119,95
GSX-R 600	C3	11-	SP	L/R	553S127	-	54,95	MA	-	550S127.1	SW	119,95
GSR 600	WVB9	06-10	DS	-	550S107	-	29,95	RA	-	550S107.1	-	99,95
GSF 650 Bandit	JS1B5	05-06	-	-	-	-	-	RA/MA	-	550S064.1	-	69,95
GSF 650 Bandit	WVCJ	07-	-	-	-	-	-	MA	-	550S117.1	-	69,95
SV 650 N/S	JS1AV	-02	DS	-	550S075	-	35,95	-	-	-	-	-
SV 650 N/S	JS1BY	03-	DS	-	550S091	-	35,95	RA	-	550S091.1	-	89,95
SFV 650 Gladius	WVCX	09-	-	-	-	-	-	RA	-	550S137.1SW		129,95
SV 650	CX	16-	-	-	-	-	-	RA	-	550S137.1SW		129,95
GSX 650F		08-	-	-	-	-	-	MA	-	550S125.1	-	89,95
GSR 750	C5	11-	DS	-	550S126	-	35,95	RA	-	550S126.1	-	119,95
GSX-R 750V	JS1BD	97-03	DS	L	550S082	-	29,95	-	-	-	-	-
GSX-R 750	JS1B3	04-05	DS	-	550S094	-	29,95	RA	-	550S097.1	-	75,95
GSX-R 750	WVCF/ WVCV	06-10	DS	L	550S108	-	29,95	MA	-	550S108.1	-	119,95
GSX-R 750	C4	11-	SP	L/R	553S127	-	54,95	MA	-	550S127.1	SW	119,95
TL1000S	JS1AG	all	DS	-	550S065	-	35,95	-	-	-	-	-
SV 1000S	JS1BX(132)	03-	DS	-	550S093	-	29,95	RA	-	550S093.1	-	89,95
GSX-R 1000	JS1BL	01-02	DS	L	550S088	-	29,95	RA	-	550S088.1	-	49,95
GSX-R 1000	JS1BZ	03-04	DS	-	550S094	-	29,95	RA	-	-	-	-
GSX-R 1000	JS1B6	05-06	DS	L	550S099	-	29,95	RA	-	550S099.1	-	79,95
GSX-R 1000	JS1CL	07-08	DS	-	550S114	-	29,95	RA	-	550S114.1	-	89,95
GSX-R 1000	WVCY	09-	DS	L/R	550S123	-	29,95	MA	-	550S123.1	-	119,95
GSX-S 1000	DG	15-	DS	-	550S135	-	29,95	-	-	-	-	-
GSX-S 1000 F /ABS	DG	15-	DS	-	550S136	-	29,95	-	-	-	-	-
GSF 1200	GV75A/JS1A9	-00/01-	DS	-	550S064	-	69,95	RA/MA	-	550S064.1	-	69,95
GSX 1200	JS1A3	all	DS	-	550S064	-	69,95	RA/MA	-	550S064.1	-	69,95
GSF 1250 Bandit	WVCH	07-	-	-	-	-	-	MA	-	550S117.1	-	69,95
GSX 1250F		10-	-	-	-	-	-	MA	-	550S125.1	-	89,95
B-King	WVCR	07-	DS	L	550S119	-	29,95	-	-	-	-	-
GSX1300 Hayabusa	JS1A1	99-07	DS	L/R	550S077	-	29,95	-	-	-	-	-
GSX1300 Hayabusa		08-	DS	L/R	550S120	-	29,95	-	-	-	-	-
GSX 1400	JS1BN	all	-	-	-	-	-	MA	-	550S089	-	75,95
Triumph												
TT600	H811	all	DS	L/R	550T022	-	29,95	-	-	-	-	-
Speed Four	H811	all	DS	-	550T028	-	29,95	-	-	-	-	-
Daytona 600	H835	03-05	DS	L/R	550T029	-	29,95	-	-	-	-	-
Daytona 675	D67LC	06-12	-	-	-	-	-	RA	-	550T037	-	119,95
Daytona 675	H67	13-	-	-	-	-	-	RA	-	550T055.1	SW	109,95
Street Triple 675	D67LD	07-12	-	-	-	-	-	RA	-	550T041	SW	59,95
Street Triple 675		13-	-	-	-	-	-	RA	-	550T053.1	SW	99,95
Street Triple 765		17-	-	-	-	-	-	RA	-	550T075.1	SW in prep.	
Tiger 800		all	-	-	-	-	-	RA	R	550T047.1	-	119,95
Thruxton /Bonneville / Scrambler	908MD/986ME	-15	-	-	-	-	-	MA	-	550T024	SW	79,95
Bonneville T100	DB01	17-	-	-	-	-	-	MA	-	550T072.1SW		119,95
Street Twin / Street Cup	DP01 / DZ01	16-	-	-	-	-	-	MA	-	550T072.1SW		119,95
Bonneville T120	DU01/1/1	16-	-	-	-	-	-	MA	-	550T072.1SW		119,95
Thruxton 1200 /R	DE01/1/1 /2	16-	-	-	-	-	-	MA	-	550T072.1SW		119,95

NEW

NEW

NEW

_ PROTECTORS CRASH PADS®

model	type	year	directly screwed				screwed with adapter plate			
			DS: directly screwed at engine bolts SP: Skid Pad, fastening same as DS				MA: across engine cover RA: with engine bolts at the frame			
			L/R: left and/or right the fairing has to be drilled SW: kit is also available in black, please complete the item no with „SW“							
Triumph										
Thunderbird	T309RT	all	DS	-	550T020	-	29,95	-	-	-
Sprint RS	T695	00-04	-	-	-	-	-	RA	L/R	550T018 - 89,95
Daytona T 595/955i	T595	97-01	-	-	-	-	-	RA	L/R	550T017 - 69,95
Daytona T 955i	595N	02-	-	-	-	-	-	RA	L/R	550T025 - 79,95
Speed Triple	595N	97-04	-	-	-	-	-	RA	-	550T027 - 59,95
Speed Triple 1050	515N/NJ2	05-10	-	-	-	-	-	RA	-	550T033 - 59,95
Speed Triple 1050	515N/NJ2	05-10	-	-	-	-	-	MA	-	550T033.1 SW 109,95
Speed Triple 1050 (6 Schrauben re)	515NV	11-	-	-	-	-	-	MA	-	550T033.1 SW 109,95
Speed Triple 1050 (5 Schrauben re)	515NV	12-	-	-	-	-	-	MA	-	550T048.1 SW 109,95
Tiger 1050	115NG	07-11	-	-	-	-	-	MA	-	550T033.1 SW 109,95
Tiger 1050	115NG	12-	-	-	-	-	-	MA	-	550T048.1 SW 109,95
Sprint ST 1050	215NA	05-	-	-	-	-	-	RA	-	550T018 - 89,95
Yamaha										
XJ 6 Diversion N/S	RJ19	09-	-	-	-	-	-	RA	L/R	550Y121 - 75,95
YZF 600R	4UT	all	DS	-	550Y069	-	29,95	-	-	-
YZF-R6	RJ03	-02	DS	L/R	550Y079	-	29,95	-	-	-
YZF-R6 / R6S	RJ05/09	03-05	-	-	-	-	-	RA	-	550Y089 - 49,95
YZF-R6	RJ11	06-07	-	-	-	-	-	RA	-	550Y104 - 55,95
YZF-R6	RJ15	08-	-	-	-	-	-	RA	-	550Y118 - 59,95
FZS 600 Fazer	RJ02	-03	DS	-	550Y078	-	35,95	-	-	-
FZ6 / Fazer	RJ07	03-	DS	-	550Y093	SW	29,95	-	-	-
FZ8 / Fazer	RN25	10-	DS	-	550Y106	-	29,95	RA	-	550Y124.1 - 55,95
MT07	RM04	14-	DS	-	550Y134SW	-	39,95	-	-	-
XSR 900 ABS	RN431	16-	DS	-	550Y129	SW	35,95	RA	-	550Y129.1 - 109,95
XSR 700 ABS	RM11	15-	DS	-	550Y134SW	-	39,95	-	-	-
TRX 850	4UN	all	DS	-	550Y071	-	35,95	-	-	-
TDM 900	RN081	02-05	-	-	-	-	-	RA	-	550Y092 - 79,95
MT09 /MT09 Tracer	RN29 /F	13-	DS	-	550Y129	SW	35,95	RA	-	550Y129.1 - 109,95
YZF 1000R	4VD	all	DS	-	550Y070	-	29,95	-	-	-
YZF-R1	RN01	98-99	-	-	-	-	-	RA	R	550Y077 - 49,95
YZF-R1	RN04	00-01	-	-	-	-	-	RA	R	550Y085 - 49,95
YZF-R1	RN09	02-03	DS	-	550Y088	-	29,95	-	-	-
YZF-R1	RN12	04-06	-	-	-	-	-	RA	-	550Y094.1 - 89,95
YZF-R1	RN19	07-08	-	-	-	-	-	RA	-	550Y115.1 - 89,95
YZF-R1	RN22	09-	DS	L/R	550Y120	-	29,95	RA	-	550Y120.1 - 99,95
YZF-R1M	RN32	15-	SP	-	553Y137	-	54,95	-	-	-
FZS 1000 Fazer	RN06/14	-05	DS	L/R	550Y086	-	35,95	-	-	-
FZ1/ FZ1 Fazer	RN16	06-	DS	-	550Y106	-	29,95	RA	-	550Y106.1 - 89,95
MT-10	RN451	16-	DS	-	550Y144SW	in prep.	-	-	-	-
BT 1100 Bulldog	RP05	all	DS	-	550Y091	-	45,95	-	-	-
XJR1200/1300	4PU /RP19	all	DS	-	550Y073	-	29,95	-	-	-
V-Max	div.	all	DS	-	550Y044	-	35,95	-	-	-
FJR 1300	RP04/ RP11	-05	-	-	-	-	-	RA	-	550Y087 - 139,95
FJR 1300	RP13	06-12	-	-	-	-	-	RA	-	550Y111 - 89,95
MT01	RP12/ RP18	05-	-	-	-	-	-	RA	-	550Y101 - 119,95

Marketa Janakova on the LSL long-distance Suzuki



AXLE BALLS FOR AXLE PROTECTION

Axle balls in the same design as our bar ends also available for the present sports models. They are mounted via continuous screwing or clamped into the hollow axles. They are supplied as a complete kit with all mounting parts and crash balls.

Depending on the model we use different solutions either with a bolt crossing from one to the other side or clamped within the axle.



version 1: bolt connection

EUR 39,95 / axle	type	year	front	rear
Aprilia				
SL 750 Shiver /GT (ABS)	RA	07-	555A019...	556A019...
SMV 750 Dorsoduro (ABS)	SM	08-	555A019...	556A019...
NA 850 Mana /GT (ABS)	RC	07-	555A019...	556A019...
RSV 1000R /Factory /Nera	RR	04-07	555A019...*	556A019...
RSV4 R /Factory /APRC	RK	09-	555A019...*	556A019...
Tuono 1000R /Factory	RR	05-10	555A019...*	556A019...
Tuono V4 R /APRC	TY	11-14	555A019...*	556A019...
Tuono V4 1100 Factory	TY	15-	555A019...	556A019...
BMW				
F 800S /ST /R (ABS)	E8ST	06-	555B030...	-
F 800R (ABS)	E8ST	06-14	555B030...	-
F 800R ABS	E8ST	15-	555B054...	-
S 1000RR /R (ABS)	K10	09-	555B040...	556B040...
S 1000XR (ABS)	K10	15-	555B054...	556B040...
R nineT	R1ST	14-	555B030...	-
R 1200S (ABS)	R12S	07-	555B030...	-
R 1200 RS	R12WR	16-	555B054...	-
Buell				
Firebolt/Lightning/City X	XB1	03-08	555BU04...	556BU04...
Ducati				
Monster 696	M5	08-	555D027...	556KT07...
749 /R /S	H5	02-07	555D027...	556D027...
Streetfighter 848	F1	12-	555D027...*	-
999 /R /S /Xerox	H4	03-06	555D027...	556D027...
Hypermotard 1100 /S	B1	08-	555D027...*	556D038...
Monster 1100 /S /EVO (ABS)	M5	09-	555D027...	-

Axle ball colours	surface	order info
black	anodised	item no .SW
titan	anodised	item no .TI
silver	anodised	item no .SI
gold	anodised	item no .GO
yellow	powder coated	item no .GE
orange	powder coated	item no .OR
signal red	powder coated	item no .SR
green	powder coated	item no .GR
white	powder coated	item no .WT
transp. red	transp. coated	item no .RT
transp. blue	transp. coated	item no .BL

COLOUR



version 2: rubber clamped

EUR 39,95 / axle	type	year	front	rear
Ducati				
1098 /S	H7	07-08	555D037...*	-
Streetfighter 1098 /S	F1	09-	555D037...*	-
1098 R /Bayliss LE	H7	08-09	555D037...*	-
Multistrada 1200 /S (ABS)	A2	10-	555D037...	-
Monster 821	M6	14-	555D037...	556D049
Monster 1200 /S	M6	14-	555D037...	-
Scrambler Icon	K1	15-	555D047...	556D047
Honda				
Hornet 600 (ABS)	PC 41	07-	555H111...	-
CBF 600 N/S (ABS)	PC 38/43	04-	555H111...	-
CBR 600 F (ABS)	PC 41	11-	555H111...	-
CBR 600 RR	PC 37	03-06	555H099...	556H090...
CBR 600 RR (ABS)	PC 40	07-	555H111...	556H103...
CB 650F	RC75	14-	555H111...	-
VFR 800X Crossrunner (ABS)	RC80	15-	555H159...	-
CBR 900 RR	SC 44	00-01	555S099...	556H090...
CBR 900 RR	SC 50	02-03	555S099...	556H090...
CB 1000 R (ABS)	SC 60	08-	555H111...	-
CBF 1000 /F (ABS)	SC 58/64	06-	555H111...	-
CBR 1000 RR	SC 57	04-07	555S099...	556H103...
CBR 1000 RR (ABS)	SC 59	08-	555H125...	556H103...
VTR 1000 SP-1 /SP-2	SC 45	00-05	555H099...	556H103...
CBR 1100 XX	SC 35	97-07	555H111...	-
VFR 1200F /mit DCT	SC63	10-	555H125...	-
VFR 1200XD Crosstourer	SC70C	10-	555H159...	-

*Shows fork only

_ PROTECTORS AXLE BALLS

EUR 39,95 / axle	type	year	front	rear
Husqvarna				
SM 510R	A2	09-	555HU01...	556HU01...
Nuda 900 /R	A7	12-	555HU02...	556HU02...
Kawasaki				
ZX-6R Ninja	ZX600P	07-08	555K101...	556K107...
ZX-6R Ninja	ZX600R	09-	555K131...	556K107...
ZX-6R Ninja	ZX636B	03-04	555K101...	556K101...
ZX-6R Ninja	ZX636C	05-06	555K101...	556K107...
ZX-6R 636 ABS Ninja	ZX636E	13-	555K126...	556K107...
Versys 650	LE650E	15-	555K147...	-
Z 650	ER650H	17-	555K135...	556K155... in prep.
Z 750R ABS	ZR750N	11-	555K126...	-
Z 800 ABS	ZR800A	13-	555K144...	-
Versys 1000	LZT00A	12-	555K126...	556K150...
Z 1000 (ABS)	ZRT00B	07-09	555K126...	556K126...
Z1000SX ABS	ZXT00W	17-	555K135...	556K135...
Z 1000 /SX /Tourer (ABS)	ZRT00D/G/L	10-16	555K135...	556K135...
Z 1000	ZRT00F	14-	555K147...	556K135...
ZX-10 R ABS	ZXT00S	16-	555K101...	556K107...
ZX-10 R Ninja	ZXT00C/D	04-07	555K105...	556K105...
ZX-10 R Ninja	ZXT00E/F	08-10	555K101...	556K105...
ZX-10 R Ninja	ZXT00J	11-	555K131...	556K107...
1400 GTR (ABS) (CBS)	ZGT40A/C	08-	555K101...	-
ZZR 1400 (ABS)	ZXT40A/C/E	06-	555K131...	-
KTM				
690 Duke	DUKE	08-11	555KT11...	556KT07...
990 SMT	LC8SM	09-	555KT07...	556KT07...
990 Super Duke	LC8EFI	05-	555KT07...	556KT07...
1190 RC 8	RC8	08-	-	556KT07...
1290 Super Duke R		14-	555KT07...	-
MV Agusta				
F3 675	F3	12-	555MV05...	-
F3 800 ABS	F3	14-	555MV05...	-
Brutale 800 ABS	B3	14-	555MV05...	-
Suzuki				
DR-Z 400 SM	WVB8	05-07	555S104...	556S104...
GSX-R 600	WVB2	04-05	555S097...	556S097...
GSX-R 600	WVCE/CV	06-10	555S099...	556S099...
GSX-R 600	C3	11-	555S127...	556S127...
GSX-R 750	WVB3	04-05	555S097...	556S097...
GSX-R 750	WVCF/CW	06-10	555S099...	556S099...
GSX-R 750	C4	11-	555S127...	556S127...
GSX-R 1000	WVB6/CL	05-08	555S099...	556S099...
GSX-R 1000	WVCY	09-11	555S099...	-
GSX-R 1000	WVCY	12-	555S130...	-

NEW

NEW

NEW

NEW

EUR 39,95 / axle	type	year	front	rear
Suzuki				
GSX-S 1000	DG	15-	555S127...	556S135...
V-Strom 1000 ABS	DD	14-	555S130...	-
SV 1000 /S	WVBX	03-05	555S097...	556S097...
GSF 1250 /S Bandit (ABS)	WVCH	07-	555S099...	556S099...
GSX 1250FA	WVCH	10-	555S099...	556Y088...
GSX 1300 BK B-King (ABS)	WVCR	08-	555S099...	556S099...
GSX 1300 R Hayabusa II	WVCK	08-	555S099...	-
Triumph				
Daytona 675	D67LC	06-10	555T037...	556T037...
Daytona 675 R	D67LC	11-12	-	556T037...
Daytona 675 R ABS	H67	13-	555T037...	556T037...
Bonneville T100	DB01	17-	555T068...	-
Bonneville T120	DU01/1/1	16-	555T068...	-
Street Twin	DP01	16-	555T068...	556T047...
Street Cup	DZ01	17-	555T068...	556T047...
Thruxton /R	DE01/1/2 /1	16-	555T066...	556T047...
Street Triple	D67LD	08-	555T037...	556T037...
Tiger 800	A08	11-	555T037...	556T047...
Daytona T595 /955i	T595/N	97-05	555T027...	-
Speed Triple	595N	02-04	555T027...	-
Speed Triple	515NJ	05-11	555T033...	-
Speed Triple (ABS)	515NV	11-	555T037...	-
Tiger 1050 (ABS)	115 NG	07-	555T033...	-
Tiger 1200 Explorer ABS	V13VG	12-	555T066...	-
Yamaha				
YZF R3	RH07	15-	555Y140...	556Y140...
FZ 6 /Fazer /S /S2 (ABS)	RJ07/14	04-	555Y105...	556Y088...
YZF-R 6 /S	RJ09	03-07	555Y088...	556Y088...
YZF-R 6	RJ 15	08-	555Y118...	556Y088...
MT-07	RM041	14-	555Y134...	-
XSR 900 ABS	RN431	16-	555Y129...	556Y129...
XSR 700 ABS	RM11	15-	555Y134...	-
FZ 8 /Fazer 8 (ABS)	RN 25	10-	-	556Y088...
MT-09	RN 29	13-	555Y129	556Y129...
FZ 1 /Fazer (ABS)	RN16	06-	555Y105...	556Y088...
FZS 1000 Fazer	RN06/14	01-05	555Y105...	-
YZF-R 1	all	02-14	555Y088...	556Y088...
YZF-R 1M	RN32	15-	555S130...	556B040...
MT-10	RN451	16-	555S130...	556B040...
XT 1200Z Super Ténéré	DO015	12-	555Y105...	-
XJR 1300	RP 19	07-14	555Y105...	556Y088...
XJR 1300	RP 19	15-	555Y105...	556Y139...
MT-01 /S	RP12/18	05-	555Y105...	556Y088...
V-Max 1700	RP 21	09-	555Y088...	-





LIFTER - CONTACT ROLLERS FOR MOUNTING STAND

We all know the hassle of bringing the gripper of the assembly stand into the small retaining studs. Racing teams in endurance racing have been using large guide rollers for many years, through which the engaging of the lift is easy to achieve.

LSL offers this experience from endurance racing for your motorbike with the LSL Lifter. These large guide rollers (diameter: 56mm) are finished in wear-resistant plastic and come with visually attractive coloured bolted mounting sleeves.





All lifters are supplied with an 8mm high spacer. Different threads are used for bolting. Check which thread is required for your motorbike.

Available treads and colours:

Lifter	item no	EUR/pair
M 6		
anthracite	680LB06AN	29,95
silver	680LB06SI	29,95
gold	680LB06GO	29,95
M 8		
anthracite	680LB08AN	29,95
silver	680LB08SI	29,95
gold	680LB08GO	29,95
green	680LB08GR	29,95

Lifter	item no	EUR/pair
M 8 + 10 mm spacer*		
anthracite	680LB08DAN	29,95
silver	680LB08DSI	29,95
gold	680LB08DGO	29,95
M 10 x 1.25		
anthracite	680LB10AN	29,95
silver	680LB10SI	29,95
gold	680LB10GO	29,95
green	680LB10GR	29,95

* Triumph Daytona 11, Tiger 800, etc.

colour Lifter	order info
anthracite 	item no ..AN
gold 	item no ..GO
green 	item no ..GR
silver 	item no ..SI

COLOUR

Summary of fitting solutions for many popular motorcycles:

Please complete the item no. by adding your favourite colour code.

model	year	item no
Aprilia		
SL 750 Shiver		680LB06...
SMV 750 Dorsoduro		680LB06...
NA 850 Mana		680LB06...
ETV 1000 Capo Nord		680LB06...
RSV 1000		680LB06...
RSV4		680LB06...
SL 1000 Falco		680LB06...
Tuono 1000		680LB06...
Tuono V4 R		680LB06...
Dorsoduro 1200		680LB06...
BMW		
S 1000RR		680LB08...
Ducati		
Monster 821		680LB06...
999 /R /S /Xerox		680LB08...
Honda		
CBR 600/900/1000 RR		680LB08...
VTR 1000 SP-1 /SP-2		680LB08...
Kawasaki		
Ninja 250R /SE		680LB10...
Ninja 300		680LB10...
ZX-6R Ninja		680LB10...
ZX-6R 636 Ninja		680LB08...
ZX-6RR Ninja		680LB10...
ER-6n /f (ABS) / Versys -14		680LB10...

model	year	item no
Kawasaki		
Versys 650 ABS	15-	680LB08...
Z 650	17-	680LB08...
Vulcan S ABS	15-	680LB10...
Z 750 /S /R		680LB10...
Z 800 ABS		680LB08...
ZX-9R Ninja		680LB10...
Z 1000		680LB10...
Z 1000 SX	17-	680LB08... NEW
Z 1000 SX	11-16	680LB10...
ZX-10 R Ninja	-15	680LB10...
ZX 10-R ABS	16-	680LB08...
ZRX 1100/1200		680LB10...
ZX-12R Ninja		680LB10...
ZZR 1400 (ABS)		680LB10...
KTM		
200 / 390 /690 Duke		680LB08...
990 SMT		680LB08...
990 Super Duke		680LB08...
1190 RC 8		680LB08...
Suzuki		
GSR 600		680LB08...
GSX-R 600		680LB08...
DL 650A V-Strom ABS		680LB08...
SFV 650 Gladius (ABS)		680LB08...
SV 650 /S / ABS		680LB08...

model	year	item no
Suzuki		
GSR 750		680LB08...
GSX-R 750/1000		680LB08...
GSX-S 1000		680LB08...
SV 1000 /S		680LB08D...
SV 1000 /S		680LB08D...
V-Strom 1000 ABS		680LB08...
GSX 1250FA		680LB08...
GSX 1300 BK B-King (ABS)		680LB08...
GSX 1300 R Hayabusa		680LB08...
Triumph		
Daytona 675	-10	680LB06...
Daytona 675	11-	680LB08D...
Street Triple		680LB06...
Street Triple R		680LB08...
Thruxton 1200 /R	16-	680LB08... NEW
Tiger 800 (ABS)		680LB08D...
Yamaha		
YZF-R 3		680LB06...
YZF-R 6 /S		680LB06...
FZ 8 /Fazer 8 (ABS)		680LB06...
TRX 850		680LB10...
MT-09		680LB06...
FZ 1 /Fazer (ABS)		680LB06...
YZF-R 1 /SP /M		680LB06...
MT- 10		680LB06...

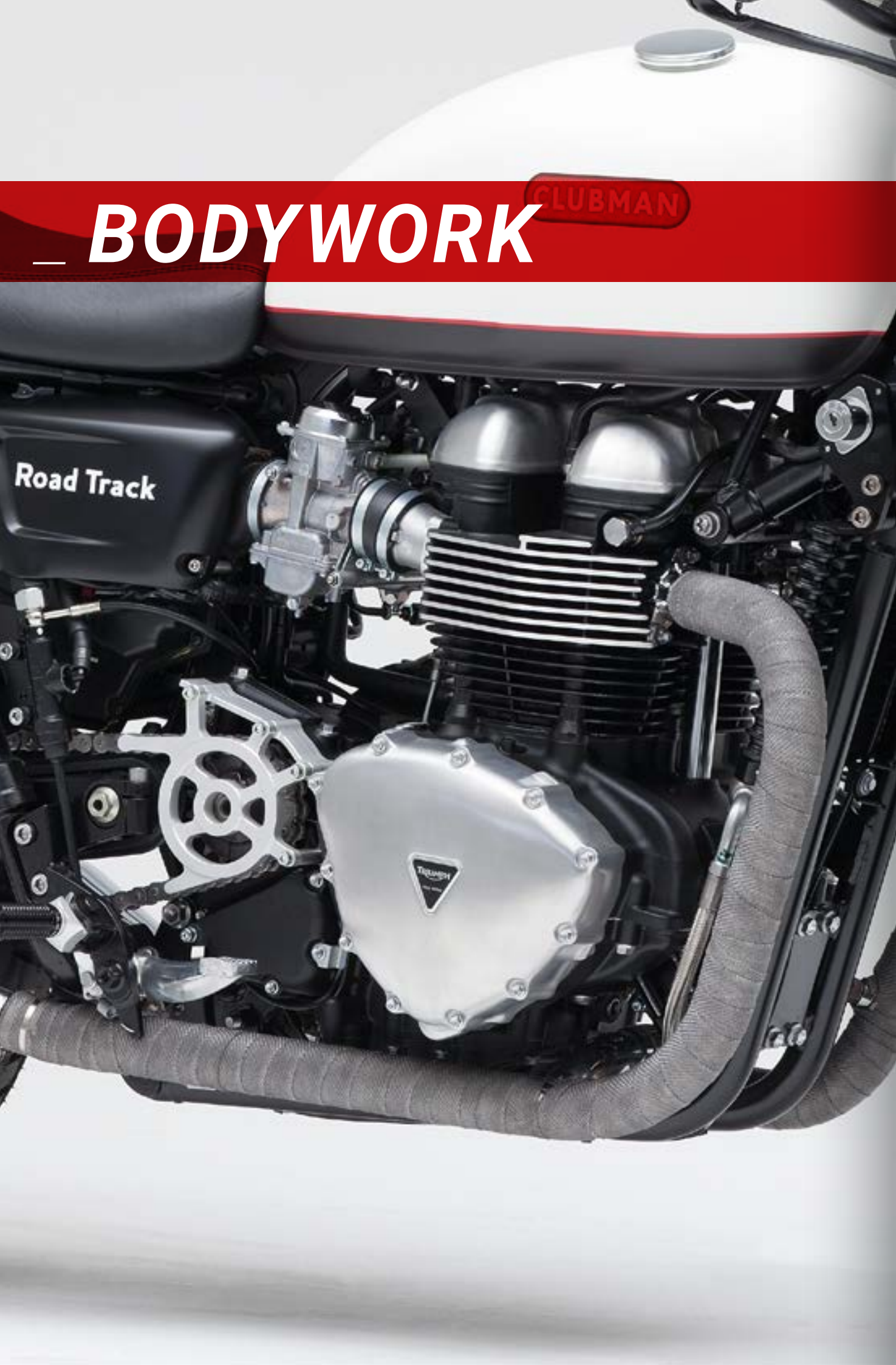

BODYWORK

Road Track

CLUBMAN





506K086G19

FRONT FENDER **EXTREME**

As the perfect complement to our GRP Extreme rear tail or paintable alternative to our aluminum fender we offer these high quality manufactured fender. The fiberglass fender is supplied unpainted.

type	year	front wheel	item no	EUR
Kawasaki				
W 650 / W 800		19" unpainted	506K086G19	169,95
Triumph, unbored				
Bonneville T100 (screwed)	all -15	19" unpainted	506T038G	99,95
Scrambler	all -16	19" unpainted	506T038G	99,95
Thruxton	all -15	18" unpainted	506T031G	99,95
Street Twin/ Street Cup	16- /17-	18" unpainted	506T068G	99,95
Bonneville T100	17-	18" unpainted	506T068G	99,95
Bonneville T120	16-	18" unpainted	506T068G	99,95

NEW
NEW



507K137LB

TAIL CONVERSION **EXTREME**
LINDY BOB

For Triumph Twins and Kawasaki W models LSL provides the Extreme GRP rear fender incl. LED taillight and license plate holder.

type	year	rear wheel	item no	EUR
Kawasaki				
W 650 / W 800		unpainted	507K137LB	199,95
Triumph				
Bonneville, Thruxton	all -15	unpainted	507T038EX	209,05
Scrambler	all -16	unpainted	507T038EX	209,05
Street Twin	16-	unpainted	507T068EX	229,95
Scrambler, Street Cup	17-	unpainted	507T068EX	229,95
Bonneville T100	17-	unpainted	507T068EX	229,95
Bonneville T120	16-	unpainted	507T068EX	229,95

NEW
NEW

_ BODYWORK ALUMINUM FENDER



MODEL SPECIFIC ALUMINUM FENDER KITS

Polished aluminum fenders, model-based and drilled with brackets for the original fender mounting. For the conversion to a different front wheeldimension on Bonneville T100

and Thruxton we offer complete kits including all necessary mounting parts. These can only be used in combination with the 10 mm wider LSL top yokes on page 16.



506Y131A

model	year	wheel position	item no	EUR
BMW				
R 100 R		front	18" 506B014A	169,95
R 100 R		rear	507B014A	199,95
Honda				
CB 1100		front	18" 506H141A	169,95
CB 1100		rear	507H141A	199,95
Kawasaki				
W 650/800		front	19" 506K086A19	169,95
W 650/800		rear	507K086A	189,95
Moto Guzzi				
V7		front	18" 506M018A	119,95
V7		rear	507M018A	189,95
Yamaha				
SR 500 / XS 650	-	front	19" 506Y017A	169,95
XV 950	-	front	19" 506Y131A	169,95
XJR 1300	-	front	17" 506Y139A	169,95
XSR 700 ABS	15-	front	17" 506Y141A	169,95
XSR 700 ABS	15-	rear	507Y141A	199,95
XSR 900 ABS	16-	front	17" 506Y143A	in prep.

model	year	wheel position	item no	EUR
Triumph				
Bonneville Gussrad	all -15	front	17" 506T044A	119,95
Bonneville Gussrad	all -15	rear	507T024A	189,95
Bonneville T100 (screwed)	all -15	front	19" 506T038A	119,95
with change from original 18" to 17"*		18"	506T03918	169,95
Bonneville T100	17-	front	18" 506T068A	119,95
Bonneville T100	17-	rear	507T068A	189,95
Bonneville T120	16-	front	18" 506T068A	119,95
Bonneville T120	16-	rear	507T068A	189,95
Scrambler	all -16	front	19" 506T038A	119,95
Scrambler	all -16	rear	507T024A	189,95
Thruxton 1200	16-	front	17" 506T072A	119,95
Thruxton 1200 R	16-	front	17" 506T071A	in prep.
Thruxton	all -15	front	18" 506T031A	119,95
with change from original 18" to 17"*		17"	506T03117	169,95
Street Twin	16-	front	18" 506T068A	119,95
Street Twin	16-	rear	507T068A	189,95
Street Cup	17-	front	18" 506T068A	119,95
Street Cup	17-	rear	507T068A	189,95

* only in combination with a LSL top yoke kit



UNIVERSAL ALUMINIUM FENDER

model	wheel position	item no	EUR
universal aluminum fender, undrilled			
L 500 mm / B 115 mm	front	17" 506A05017	79,95
L 500 mm / B 105 mm	front	18" 506A05018	79,95
L 600 mm / B 105 mm	front	18" 506A06018	79,95
L 600 mm / B 105 mm	front	19" 506A06019	79,95
L 800 mm / B 105 mm	front	19" 506A08019	89,95
L 700 mm / B 105 mm	front	21" 506A07021	89,95
L 700 mm / B 92 mm	front	21" 506A07021-9	89,95
L 520 / B 145 mm, radius 400 mm	rear	507A052	94,95
L 600 / B 145 mm, radius 400 mm	rear	507A060	99,95
L 1000 / B 145mm, radius 400 mm	rear	507A100	109,95
L 600 / B 180 mm, radius 400 mm	rear	507A060B18	119,95
L 600 / B 195 mm, radius 400 mm	rear	507A060B19	119,95



MODEL SPECIFIC FENDER BRACKET

Stainless steel fnder brackets in different sizes. See grafic for the dimensions.

front	X	Y	Z	item no	EUR
BMW					
R100R	60	63	14	506HTB014	49,95
Honda					
CB1100A	80	77	3	506HTH141	49,95
Kawasaki					
W650/800	50	65	12	506HTK086	49,95
Yamaha					
SR500/XS650	60	88	20	506HTY017	49,95
XV950	90	50	12	506HTY131	49,95
XJR1300	70	85	15	506HTY139	49,95

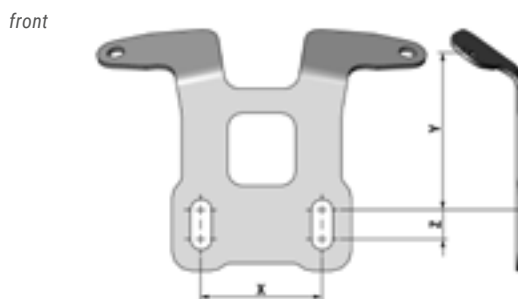

UNIVERSAL FENDER BRACKET

rear	A1	A2	item no	EUR
universal bracket for aluminum fenders				
for a width of 145 mm	42 mm	76 mm	507-B14A	19,95

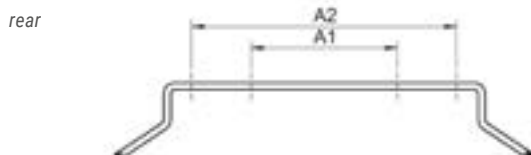

CLASSIC SEATS

The seat of a motorcycle is an essential part of the optical „line“ of the bike and of course also has an important influence on the ergonomics. Therefore, it is only logical that LSL also takes care of this component. Our seats fit in perfectly with the classic Clubman style and are handcrafted individually by order.



Lindy Bob seat

Seats	item no	EUR
Lindy Bob seat (picture left)		
Kawasaki W 650/ W 800	502K137LB	439,00
Extreme seat (picture right)		
Triumph Bonneville/ Thruxton/ Scrambler -15	502T038EX	399,00

NEW



Extreme seat

CLUBMAN® LEATHER CASE

The 4 mm thick full grain leather tool bag fits perfectly to many retro classics. It is provided with a stable closure. Specific mounting kits for various models are in preparation. Alternatively, the supplied straps are used to fasten. Dimensions: 24 x 14 x 7cm.

The size of the Clubman® leather bag is ideal for taking a motorcycle first-aid kit.

product	year	position	item no	EUR
Clubman leather case				
Case, black			950CL01	149,95
brackets				
Ducati Scrambler Icon	15-	right	951D047	59,95
Kawasaki W800		right	951K137	49,95
Moto Guzzi V7		right	951M020	59,95
Bonneville, Scrambler, Thruxton	-15	left	951T024	49,95
Triumph Street Twin	16-	left	951T068	49,95
Triumph Thruxton 1200 /R	16-	left	951T068	49,95
motorcycle first aid kit				
Motorcycle first aid kit			960VM01	12,95

NEW



In Austria it is mandatory to have a motorcycle first aid kit.



ALUMINUM KNURLED HEAD SCREWS

to fix side covers or tool boxes etc. Extra long version to mount the seats of Bonneville and Thruxton.

product	dimensions	item no	EUR
knurled head screws			
knop 24 mm	M6 x 20 mm	317T024B	19,95
knop 32 mm	M6 x 20 mm	317T024	19,95
knop 90 mm	M6 x 20 mm	317T024-90	28,95

variant B, 330B049

ALUMINUM OIL FILLER CAP

The LSL oil filler cap is made of high quality milled aluminum and anodized with a special process bicolored (silver/blue-metal). Also the translucent silvery surfaces are protected against oxidation. All plugs are with transverse hole for the safety wire and are supplied with new O-ring.

Please notice that th filler cap has no oil level control!

VAR	thread	item no	EUR
variant			
B	M 34 x 1.5	330B049	39,95
H	M 24 x 3.0	330H045	39,95
S	M 20 x 1.5	330S064	39,95
Y	M 27 x 1.5	330Y081	39,95

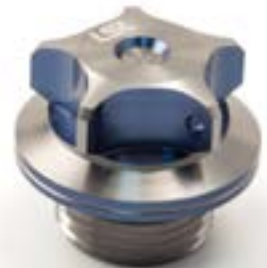

variant S, 330S064

model	type	year	VAR
Aprilia			
RS250	LD	94-03	S
RXV 450-550	VS	06-15	S
SXV 450-550	VP	06-15	S
SL750 Shiver	RA	08-16	S
RSV 1000, 2-Zylinder	all	98-11	S
Caponord 1200	VK	13-16	S
Dorsoduro 1200	TV	10-13	S
BMW			
F 650 (Zweizylinder)	K72	08-12	H
F 700 (Zweizylinder)	K70	13-16	H
F 800 (Zweizylinder)	K71, K72, K75	08-	H
R nine T	K 21	14-	B
R 900 RT, R 1200 RT	K 26	05 -	B
R 1200 GS	K 25	04 -	B
R 1200 R	K 27	06 -	B
R 1200 S, HP2 Sport	K 29		B
R 1200 ST	K 28		B
R 1200 RS	R12WR	15-	B
Honda			
CB 400 SF		92-97	H
VFR 400 F/R		82-88	H
CB 750F		79-82	H
VF 750 Magna			H
VFR 750F		86-90	H
VFR 750R		87	H
RVF 750		94-95	H
VFR 800F		00-07	H
CB 1100F / R		81-83	H
X 11		99	H
CBR 1100XX		97-01	H
CB 1300		03-15	H
GL 1500 Gold Wing		96-99	H
Kawasaki			
KLV 1000	KLV1000A	04-05	S

model	type	year	VAR
KTM			
350 EXC-F	all	all	H
400	all	all	H
450	all	all	H
505	all	all	H
525	all	all	H
530	all	all	H
625	all	all	H
640	all	all	H
660	all	all	H
690 Duke	all	all	H
950	all	all	H
990	all	all	H
1050 Adventure	all	all	H
1190 Adventure	all	all	H
1290 Super Duke R	V3	14-	H
Suzuki			
RM 125			S
TS 125R			S
VanVan 200			S
DR 250R			S
RGV 350		88-94	S
DRZ 400			S
GSF 400 Bandit		89-97	S
GSX 400 F/S/ Katana		84-	S
RG 500 Gamma		85-	S
GSR 600	WVB9	06-10	S
GSX-R 600	AD/WVBBG/CE/CV	97-	S
DL 650A V-Strom ABS	C7	12-	S
SV 650 /S (ABS)	AV/WVBY	99-08	S
SV650 ABS	CX	16-	S
SFV 650 Gladius (ABS)	WVCX	09-	S
GSX 750 ES/EF/Katana		82-	S
GSR 750		11-15	S
GSX-S 750		17-	S

model	type	year	VAR
Suzuki			
GSX 750 R		85-87	S
GSX 750R J		88-91	S
GSX-R 750 W		92-99	S
GSX-R 750		00-	S
VL 800 Intruder			S
VZ 800 Marauder			S
RF 900F			S
DL 1000V		02-	S
TL 1000 R			S
TL 1000 S			S
SV 1000 /S	WVBX	03-05	S
GSX-R 1000		01-06	S
GSX-R 1000		07-08	S
GSX-R 1000		09-15	S
GSX-R 1100 W		93-96	S
GSX-S 1000	DG	15-	S
GSX-S 1000 F	DG	15-	S
GSX 1200 INAZUMA			S
GSF 1200 N/F/S		95-	S
GSF 1250 /FA /S Bandit (ABS)	WVCH	07-	S
GSX 1300 BK B-King (ABS)	WVCR	08-	S
GSX 1300 R Hayabusa /II	WVA1/WVCK	99-	S
GSX 1400		01-07	S
Yamaha			
XT 250X		06-08	S
Tricker		04-14	S
XJR 400			Y
FZX 750			Y
V-Max		09-15	Y
XJR 1300		98-15	Y
XVZ 1300 Royal Star		96-99	Y

NEW

ALUMINUM CHAIN GUARD

Mounting as original at the swinging arm; available in aluminum-silver or black anodised. For Speed Triple models with extra carbon-fibre guide rail for the brake hose.



model	year	item no black	item no silver	EUR
Honda				
CB 1100	all	713H141SW	713H141SI	49,95
Husqvarna				
Nuda 900 R	12-	-	713HU02SI	59,95
Nuda 900	12-	-	713HU02SI	59,95
Kawasaki				
W 650	all	713K086SW	713K086SI	39,95
W 800	all	713K086SW	713K086SI	39,95
Z 1000	14-	713K147SW	713K147SI	59,95
Triumph				
Scrambler	all -16	713T024SW	713T024SI	49,95
Thruxton	all -15	713T024SW	713T024SI	49,95
Bonneville	all -15	713T024SW	713T024SI	49,95
Steet Twin/ Street Cup	16- /17-	713T068SW	713T068SI	49,95
Bonneville T100	17-	713T068SW	713T068SI	49,95
Bonneville T120	16-	713T068SW	713T068SI	49,95
Thruxton R	16-	713T071SW	713T071SI	49,95
Thruxton	16-	713T071SW	713T071SI	49,95
Speed Triple	97-04	-	713T014	89,95
Speed Triple 1050	05-10	713T033SW	713T033SI	89,95
Yamaha				
XSR 700 ABS	all	713Y141SW	713Y141SI	109,95

NEW
NEW

SPROCKET COVER

The CNC-machined LSL sprocket cover replaces the simple original plastic.



model	type	year	item no	EUR
Ducati				
Ducati Scrambler Icon	K1	15-	712D047SI	59,95
Ducati Scrambler Icon	K1	15-	712D047SW	59,95
Triumph				
Bonni/Thruxton/Scrambler	MD/ME	-15	712T024SI	59,95
Bonni/Thruxton/Scrambler	MD/ME	-15	712T024SW	59,95
Street Triple/Daytona 675	D67LD	07-/06-	712T041	39,95
Street Triple/Daytona 675	D67LD	07-/06-	712T041SW	39,95
Speed Triple 1050	515NJ	05-07	712T033	59,95
Speed Triple 1050	515NJ	05-07	712T033SW	59,95
Speed Triple 1050	515NJ	08-15	712T046	59,95
Speed Triple 1050	515NV	08-15	712T046SW	59,95

ALUMINUM ENGINE COVER

High quality, CNC-machined engine cover for right and left side. Available in silver and titanium colour. New for 2016 Triumph Modern Classic serie.



product	colour	item no	EUR
Kawasaki Z 1000			
engine cover	black	420K102SW	39,95
engine cover	silver	420K102SI	39,95
engine cover	gold	420K102GO	39,95
Triumph Bonneville T100/ T120 / Street Twin/ Cup / Thruxton/ R / from 2016			
engine cover left	silver	420T068LSI	39,95
engine cover right	silver	420T068RSI	39,95
engine cover left	titan	420T068LTI	39,95
engine cover right	titan	420T068RTI	39,95
Yamaha XS 650			
rectifier cover	silver	420Y017SI	39,95
rectifier cover	anthracite	420Y017AN	39,95

NEW

INJECTION COVER

This part protects the injection system against sidewise hits. It's made of massive machined aluminum.



model	year	colour	item no	EUR
injection cover				
Kawasaki W800	all	black	438K137SW	32,95
Kawasaki W800	all	silver	438K137SI	32,95
Kawasaki Z1000	14-	black	438K147SW	35,95
Kawasaki Z1000	14-	silver	438K147SI	35,95

BRAKE PUMP PROTECTION REAR

The skid wise machined brake cylinder guard protects the sensible push rod system against damage.



model	Bj	colour	item no	EUR
brake pump protection rear				
Triumph Scrambler	-16	black	715T038SW	32,95
Triumph Scrambler	-16	silver	715T038SI	32,95

ALUMINUM ENGINE PROTECTION

Aluminum plate to protect the engine housing against damages. Optional in silver or black anodized. Engine guard comes with all mouting material.



model	colour	item no	EUR
engine protection			
W650 / W800	silver	425K086SI	129,95
W650 / W800	black	425K086SW	129,95

MANIFOLDS INSULATING WRAP

Insulating wrap for exhaust pipes. Protection against the burning hot temperatures.



model	item no	EUR
insulating wrap		
insulating wrap 50 mm / 16 m	anthracite 416-EW2AN	89,95
Locking Tie, 4 p/pc/ 200 mm	416-LT8VA	12,95

EXTRA STRONG FORK GAITERS

Protection against stone pitch for die Triumph 41mm-fork.

model	item no	EUR
fork gaiters		
Triumph Bonneville/Thruxton	-15 148T024	59,95



_ BODYWORK NUMBER PLATE HOLDER



ALUMINUM NUMBER PLATE HOLDER

are also available for a number of naked bikes and sport bikes. Please check the model table on our web site www.LSL.eu.

The number plate bracket is made from 2 mm aluminum and is extremely rigid because of its double folded design. A rubber plug is used to support the number plate on its bottom side. Depending on the original components of the bike the plate holder bracket comes with number plate illumination or complete LED tail light.

TRIPLE TAIL CONVERSION

Where necessary the conversion kit for the Triumph Triples includes a new rear frame cover made of black color GRP, milled holder and the license plate holder with LED taillight.

For Bonneville and Thruxton models LSL delivers an inner fender as splash guard.

For fixing the turn signals (not included), corresponding mounting holes are provided. Depending on the version of the flasher, mounting poles could be required for renewal, please see page 127.



460T041

model	year	item no	EUR
tail modification with plate holder			
Triumph Bonneville/Thruxton	-15	460T031	229,00
Triumph Scrambler	-15	460T031	229,00
Triumph Street Triple	-12	460T041	239,00
Triumph Speed Triple 1050	05-07	460T033	229,00
Triumph Speed Triple 1050	08-10	460T042	239,00
Triumph Speed Triple 1050	11-	460T046	109,95
number plate holder			
BMW*	S1000RR	09-	460B040 99,95
*Bracket for original BMW flashers			460B040BK 9,95
Honda	CB 1000R	08-	460H127 89,95
Honda	CBR 600F	11-	460H127 89,95
Kawasaki	ZX6R	09-	460K131 89,95
Kawasaki	Z800	13-	460K144 99,95
Kawasaki	Z1000	07-09	460K126 99,95
Kawasaki	Z1000	10-	460K135 99,95
Kawasaki	Z1000	14-	460K147 99,95
Kawasaki	Z1000SX	all	460K138 99,95
KTM	690 Duke	08-	460KT11 89,95
Suzuki	GSX-R 600/750	11-	460S127 89,95
Suzuki	GSX R 1000	09-	460S123 89,95
Suzuki	GSX-S 1000 /F ABS	15-	460S135 99,95
Triumph	Street Triple	13-	460T053 169,00
Triumph	Daytona	13-	460T053 169,00
Triumph	Thruxton 1200 / R	16-	460T072 in prep.

model	year	item no	EUR
number plate holder			
Yamaha	YZF R6	06-10	460Y118 89,95
Yamaha	FZ8/Fazer 8	all	460Y106 119,95
Yamaha	MT-09	14-	460Y129 89,95
Yamaha	FZ1/Fazer	all	460Y106 119,95
Yamaha	YZF R1	09-11	460Y120 89,95
Yamaha	MT-10	16-	460Y120 89,95

rear light			
Yamaha MT-09 rear light with mounting frame		731Y129	99,95



NUMBER PLATE HOLDER FOR ALUMINUM FENDER

License plate holder for mounting on the aluminum fender. Is supplied with a new license plate light and separate cat's-eye, also suitable for other rounded universal fenders.



460CLAT

number plate holder		
Clubman, top-mounting	460CLAT	49,95

NUMBER PLATE HOLDER OR GFK FENDER

License plate holder for mounting below the GfK-fender. Is supplied with new license plate light and separate cat's-eye, also suitable for other flat universal fenders.



460CLEX

number plate holder		
Extreme, under-mounting	460CLEX	49,95

NUMBER PLATE HOLDER UNIVERSAL

Plate holders and accessories are also available separately. Thereby it is also possible to mount the license plate holder by your own solution on other motorcycle models.



460-UNI-B

model	item no	EUR
universal number plate holder		
number plate holder with lightning	460-UNI	59,95
number plate holder with LED rear light	460-UNI-B	85,95

NUMBER PLATE HOLDER DUCATI SCRAMBLER

LSL has designed a new license plate holder for the Ducati Scrambler. The steel pipe bracket is mounted at the attachment points of the swing arm, a CNC billet aluminum plate carries the license plate and the original license plate light.



model	item no	EUR
Ducati number plate holder		
Scrambler Icon, Full Throttle, Urban	460D047	189,95
<i>Not for model Scrambler Classic</i>		

UNIVERSAL PARTS

Brackets for reflectors matching the LSL license plate holder, adjustable in length. Universal number plate light with LED technic.

model	item no	EUR
reflector		
With adjustable bracket	460RS01	14,95
Inflexible, with bracket for riveting	460RS02	9,95
license plate light		
Universal license plate light, 47 mm	732ULD3	19,95



460RS02

732ULD3

_ LIGHTING



CLASSIC HEADLIGHT

We have the right lamp housing for many conversions. They can be mounted with many available braces on many models.

product	lens	colour	width	item no	EUR
headlight					
1 Six Days	clear glass	black/chrome	160 mm	730SD02SC	89,95
1 Six Days	clear glass	black	160 mm	730SD02SW	89,95
2 Scrambler	ripped glass	matt black	160 mm	730SD03SW	89,95
2 Scrambler	ripped glass	black/chrome	160 mm	730SD03SC	89,95
3 Clubman	plexiglass	matt black	180 mm	730KL02SW	89,95
3 Clubman	plexiglass	chrome	180 mm	730KL02	89,95
3 Clubman	plexiglass	black/chrome	180 mm	730KL02SC	89,95
4 Eighties	plexiglass	black/chrome	195 mm	730K009	89,95
4 Eighties	plexiglass	black	195 mm	730K009SW	89,95

NEW



_ 1 **SIX DAYS**
160 mm clear glass, H4, lamp ring black or chrome, E-marked.



_ 2 **SCRAMBLER**
160 mm ripped glass, lamp housing matt black or black, lamp ring matt black or chrome.



_ 3 **CLUBMAN®**
180 mm/6,5" plexiglass, housing pulled generously deep, optional chrome or matt black.



_ 4 **EIGHTIES**
195 mm/6,5" plexiglass, flat lamp housing in matt black, lamp ring chrome or black. Also for left-hand drive!

HEAD LIGHT GRID
CLASSIC

LSL offers a classic headlight grid with transverse wire mesh for the Six Days and Scrambler headlight. LSL typical the grid is designed in a high quality with a thickness of 5 mm. (Cult photo s. left)



Classic	item no	EUR
head light grid		
Classical lamp grid, black	735SC02SW	89,95
Diameter 160mm, light width of the bracket 190mm		

HEAD LIGHT GRID
RADIO-GUARD

As an alternative to the classic wire mesh, LSL also offers a laser-cut headlight grid in the design of a radio antenna. Especially made for the Six Days head light.



Radio-Guard	item no	EUR
head light grid		
Radio-Guard, stainless steel	735SCRGP0	59,95
Diameter 160mm, light width of the bracket 190mm		

_ LIGHTING HEADLIGHT BRACKETS

HEADLIGHT BRACKETS FOR CONVENTIONAL HEADLIGHTS

LSL offers universal mounting kits for an individual modification of the headlight. The bracket is made of milled aluminum, the holding clamps are available in different diameters for the most popular naked bikes.

The braces are available in short and standard version, the standard version is also available without a turn signal mounting. In a fourth variant, the lamp holders are equipped with stainless steel braces.

Due to a lateral displacement of the bearing surfaces a difference of 20 mm can be compensated by mounting the lamp braces (not for VA-braces); so the use is possible even with different fork widths or lamp sizes.

For parts or for later upgrading, it is possible to buy clamps or braces separately. You will find these on www.LSL.eu within the category headlights.

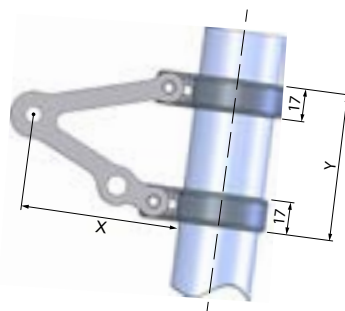

_ 1 STANDARD WITHOUT HOLES FOR INDICATORS

X = 97 mm, Y = 74 mm



_ 2 STANDARD WITH HOLES FOR INDICATORS

X = 97 mm, Y = 74 mm



_ 3 SHORT WITH HOLES FOR INDICATORS

X = 82 mm, Y = 74 mm



_ 4 EXTRA SHORT WITH HOLES FOR INDICATORS

X = 55 mm, Y = 70 mm



_ 5 STAINLESS STEEL WITH HOLES FOR INDICATORS

X = 90 mm, Y = 94 mm



_ 6 STAINLESS STEEL WITH HOLES FOR INDICATORS

X = 90 mm, Y = 94 mm



HEADLIGHT BRACKETS FOR CONVENTIONAL HEADLIGHTS

Ø	1 standard without holes for indicators X=97, Y=74 mm	2 standard with holes for indicators X=97, Y=74 mm	3 short with holes for indicators X=82, Y=74 mm	4 extra short with holes for indicators X=55, Y=70 mm	EUR	Ø	5 stainless steel without holes for indicators X=90 Y=94mm	6 stainless steel with holes for indicators X=90 Y=94mm	EUR
aluminum headlight brackets						stainless steel headlight brackets			
35 mm	143LT35	143LT35B	143LT35K	143LT35XK	119,95	35 mm	143LT35VA	143LT35VB	149,95
36 mm	143LT36	143LT36B	143LT36K	143LT36XK	119,95	36 mm	143LT36VA	143LT36VB	149,95
38 mm	143LT38	143LT38B	143LT38K	143LT38XK	119,95	38 mm	143LT38VA	143LT38VB	149,95
39 mm	143LT39	143LT39B	143LT39K	143LT39XK	119,95	39 mm	143LT39VA	143LT39VB	149,95
40 mm	143LT40	143LT40B	143LT40K	143LT40XK	119,95	40 mm	143LT40VA	143LT40VB	149,95
41 mm	143LT41	143LT41B	143LT41K	143LT41XK	119,95	41 mm	143LT41VA	143LT41VB	149,95
43 mm	143LT43	143LT43B	143LT43K	143LT43XK	119,95	43 mm	143LT43VA	143LT43VB	149,95
45 mm	143LT45	143LT45B	143LT45K	143LT45XK	119,95	45 mm	143LT45VA	143LT45VB	149,95
48 mm	143LT48	143LT48B	143LT48K	143LT48XK	119,95	48 mm	143LT48VA	143LT48VB	149,95
50 mm	143LT50	143LT50B	143LT50K	143LT50XK	119,95	50 mm	143LT50VA	143LT50VB	149,95
50/52 mm	143LT50-52	143LT50-52B	143LT50-52K	143LT50-52XK	119,95	50/52 mm	143LT50-52VA	143LT50-52VB	149,95
50/53 mm	143LT50-53	143LT50-53B	143LT50-53K	143LT50-53XK	119,95	50/53 mm	143LT50-53VA	143LT50-53VB	149,95
50/54 mm	143LT50-54	143LT50-54B	143LT50-54K	143LT50-54XK	119,95	50/54 mm	143LT50-54VA	143LT50-54VB	149,95
50/55 mm	143LT50-55	143LT50-55B	143LT50-55K	143LT50-55XK	119,95	50/55 mm	143LT50-55VA	143LT50-55VB	149,95
51 mm	143LT51	143LT51B	143LT51K	143LT51XK	119,95	51 mm	143LT51VA	143LT51VB	149,95
51/53 mm	143LT51-53	143LT51-53B	143LT51-53K	143LT51-53XK	119,95	51/53 mm	143LT51-53VA	143LT51-53VB	149,95
51/54 mm	143LT51-54	143LT51-54B	143LT51-54K	143LT51-54XK	119,95	51/54 mm	143LT51-54VA	143LT51-54VB	149,95
52 mm	143LT52	143LT52B	143LT52K	143LT52XK	119,95	52 mm	143LT52VA	143LT52VB	149,95
52/55 mm	143LT52-55	143LT52-55B	143LT52-55K	143LT52-55XK	119,95	52/55 mm	143LT52-55VA	143LT52-55VB	149,95
53 mm	143LT53	143LT53B	143LT53K	143LT53XK	119,95	53 mm	143LT53VA	143LT53VB	149,95
53/54 mm	143LT53-54	143LT53-54B	143LT53-54K	143LT53-54XK	119,95	53/54 mm	143LT53-54VA	143LT53-54VB	149,95
53/55 mm	143LT53-55	143LT53-55B	143LT53-55K	143LT53-55XK	119,95	53/55 mm	143LT53-55VA	143LT53-55VB	149,95
54 mm	143LT54	143LT54B	143LT54K	143LT54XK	119,95	54 mm	143LT54VA	143LT54VB	149,95
54/55 mm	143LT54-55	143LT54-55B	143LT54-55K	143LT54-55XK	119,95	54/55 mm	143LT54-55VA	143LT54-55VB	149,95
55 mm	143LT55	143LT55B	143LT55K	143LT55XK	119,95	55 mm	143LT55VA	143LT55VB	149,95
55/56 mm	143LT55-56	143LT55-56B	143LT55-56K	143LT55-56XK	149,95	55 mm	143LT55-56VA	143LT55-56VB	179,95
57 mm	143LT57	143LT57B	143LT57K	143LT57XK	149,95	57 mm	143LT57VA	143LT57VB	179,95
59 mm	143LT59	143LT59B	143LT59K	143LT59XK	149,95	59 mm	143LT59VA	143LT59VB	179,95

DISTANCE MOUNTINGS WITH RUBBER

Rubber supported distances for the head light bolting

distance mountings with rubber				
M8 alumnum/rubber black	Ø 28 mm	height 8 mm	143-VG1SW	14,95



NEW

HEADLIGHT FIXING KITS MODEL SPECIFIC

These kits provide a substitute for the fixing of the original headlights and include all required components. For other headlights other braces may be recommended depending on the mounting depth. In this case, please

choose the necessary components yourself or get advice from our sales team – you can find the individual components on this page.

model	type	year	item no	EUR
BMW				
R nineT	R1ST	14-	143B049	179,95
	- aluminum cover for lower top yoke		144B049BSI	39,95
Husqvarna				
Nuda 900	A7	12-	143HU02	238,95
Triumph				
Street Triple 675/R	D67LD	07-13/12	143T041	219,95
Street Triple R	L67LR	13-	143T053*	219,95
Street Twin	DP01	16-	143T068	219,90
Street Twin	DP01	16-	143T068VA	249,90
Speed Triple 509	T509	08-	143LT45	119,95
Speed Triple 955i	595N	02-04	143T027	179,95
Speed Triple 1050	515N	05-11	143T042	179,95
Speed Triple 1050	515NV	11-	143T046	219,95

* Designed for housing depth of the Eighties headlight



_ LIGHTING **URBAN HEADLIGHT**



URBAN HEADLIGHT WITHOUT BRACKETS

Urban headlight in modern urban style, material: plastic / clear glass. Also for left-hand drive!

headlight lens	width	colour	item no	EUR
Urban headlight				
plexiglass klar	180 mm	black	730Y105	119,95

URBAN HEADLIGHT WITH UNIVERSAL BRACKETS

The bracket is machined from solid aluminum; the holding clamps are available in various fork diameters for standard Naked Bikes. The fork width may need to be offset by appropriate sleeves. The distance between the slider tube clamps is 115 mm.

When planning, please note that the spotlight is placed very close to the fork for optical reasons. A conflict with the original instruments / brackets and the ignition switch may occur, depending on the bike.

Urban kits	colour	299,00 EUR
55 mm		
35 mm	silver	405-035
35 mm	black	405-035SW
36 mm	silver	405-036
36 mm	black	405-036SW
38 mm	silver	405-038
38 mm	black	405-038SW
39 mm	silver	405-039
39 mm	black	405-039SW
40 mm	silver	405-040
40 mm	black	405-040SW
41 mm	silver	405-041
41 mm	black	405-041SW
43 mm	silver	405-043
43 mm	black	405-043SW
45 mm	silver	405-045
45 mm	black	405-045SW
50 mm	silver	405-050
50 mm	black	405-050SW
50/52 mm	silver	405-050-52

Urban kits	colour	299,00 EUR
55 mm		
50/52 mm	black	405-050-52SW
50/53 mm	silver	405-050-53
50/53 mm	black	405-050-53SW
50/54 mm	silver	405-050-54
50/54 mm	black	405-050-54SW
50/55 mm	silver	405-050-55
50/55 mm	black	405-050-55SW
51 mm	silver	405-051
51 mm	black	405-051SW
51/53 mm	silver	405-051-53
51/53 mm	black	405-051-53SW
51/54 mm	silver	405-051-54
51/54 mm	black	405-051-54SW
52 mm	silver	405-052
52 mm	black	405-052SW
52/55 mm	silver	405-052-55
52/55 mm	black	405-052-55SW
53 mm	silver	405-053
53 mm	black	405-053SW

Urban kits	colour	299,00 EUR
55 mm		
53/54 mm	silver	405-053-54
53/54 mm	black	405-053-54SW
53/55 mm	silver	405-053-55
53/55 mm	black	405-053-55SW
54 mm	silver	405-054
54 mm	black	405-054SW
54/55 mm	silver	405-054-55
54/55 mm	black	405-054-55SW
55 mm	silver	405-055
55 mm	black	405-055SW

Urban kits	colour	329,00 EUR
up to 57 mm		
57 mm	silver	405-057
57 mm	black	405-057SW
59 mm	silver	405-059
59 mm	black	405-059SW



Milled aluminum bracket kit with clamps.

URBAN HEADLIGHT WITH MODEL SPECIFIC BRACKETS

For some motorcycle models LSL offers model-based headlight kits. These kits include a new, milled instrument holder and the necessary mounting hardware.

As a substitute for the forcibly loss of the air inlet on the Street Triple and the new Speed Triple models (standard in the lamp holder) a new inlet panel is used in the intake tract.

model	type	year	black brackets	silver brackets	EUR
Triumph					
Street Triple 675/ R	D67LD	07-	405T041SW	405T041	399,00
Street Triple R	L67LR	13-	405T053SW	405T053	399,00
Speed Triple 955i	595N	02-04	405T027SW	405T027	359,00
Speed Triple 1050	515N	05-11	405T042SW	405T042	359,00
Speed Triple 1050	515NV	11-	405T046SW	405T046	399,00
Yamaha					
XSR 900 ABS	RN431	16-	405Y129SW	405Y129	309,00
MT-09	D67LD	14-	405Y129SW	405Y129	309,00

IGNITION RELOCATION KIT

Necessary for relocating the ignition lock on the frame side during conversion of headlight brackets of Triumph Bonneville, Scrambler and Thruxton models.

model	colour	item no	EUR
ignition lock bracket			
Bonneville Scrambler Thruxton	silver	728T024RSI	32,95
Bonneville Scrambler Thruxton	black	728T024RSW	32,95



BRACKET KIT RECTIFIER & HORN

To relocate the units to the frame.

model	item no	EUR
bracket kit rectifier & horn		
Triumph Twins	728TR50	49,95



_ LIGHTING INDICATORS & REAR LIGHTS

INDICATORS

MOTOGADGET - INDICATORS

LED turn signals in radically new design. Using the new TranzLight-Technology (patent pending), the transparent turn signal body becomes the light-emitting media itself.

TranzLight-Technology smartly uses the total internal reflection of light waves at the interfaces of two different optical media densities. All types are ECE tested.



_ 1 D-LIGHT **BLACK**



_ 1 D-LIGHT **SATIN SILVER**



_ 1 D-LIGHT **VERCHROMT**



_ 2 M-BLAZE **DISC**



_ 3 M-BLAZE **CONE**



_ 4 M-BLAZE **ICE**



_ 5 M-BLAZE **PIN**

indicators	permission	dimensions	position	item no	count	EUR
indicators						
1 D-Light, black, grey glass	ECE	head: 52 x 18 mm, length: 69 mm	left/right	720DL01SW	pair	89,95
1 D-Light, satin silver, grey glass	ECE	head: 52 x 18 mm, length: 69 mm	left/right	720DL01SI	pair	89,95
1 D-Light, chromed, grey glass	ECE	head: 52 x 18 mm, length: 69 mm	left/right	720DL01CR	pair	89,95
Motogadget-indicators						
2 m-Blaze DISC	ECE	head: Ø 35 mm, length: 20 mm	left	720MGBDL	p/pc	99,00
2 m-Blaze DISC	ECE	head: Ø 35 mm, length: 20 mm	right	720MGBDR	p/pc	99,00
3 m-Blaze CONE	ECE	head: Ø 35 mm, length: 43 mm	left	720MGBLL	p/pc	95,00
3 m-Blaze CONE	ECE	head: Ø 35 mm, length: 43 mm	right	720MGBLR	p/pc	95,00
4 m-Blaze Ice, black	ECE	head: Ø 20,5 mm, length: 65 mm	left/right	720MGBISW	p/pc	59,00
4 m-Blaze Ice, polished	ECE	head: Ø 20,5 mm, length: 65 mm	left/right	720MGBIPO	p/pc	59,00
5 m-Blaze Pin, black	ECE	head: Ø 16 mm, length: 19,5 mm	left/right	720MGBPSW	p/pc	39,00
5 m-Blaze Pin, polished	ECE	head: Ø 16 mm, length: 19,5 mm	left/right	720MGBPCR	p/pc	39,00

REAR LIGHTS & INDICATORS ACCESSORIES



_ 6 LED MINI

Extrem small LED back light with integrated number plate lighting.



_ 7 NEW LUCAS-STYLE

LED back light, strong LED lenses, no number plate lighting.



_ 8 CLUBMAN®

Classical mini back light with LED. The Bracket is made of machined aluminum, red glass.



_ 9 CLASSIC LUCAS-STYLE

This tail light in a classic design matches perfectly our aluminum fenders.



_ 10 REFLECTOR

reflector, adjustable in the position.



_ 11 LICENSE PLATE LIGHT

Universal license plate light

rear lights	permission	dimensions	plate light	lamp	item no	count	EUR
rear lights							
6 LED Mini, white glass	-	105 x 28 mm	no	LED	731-DE1.2	p/pc	39,95
6 LED Mini, red glass (not illustrated)	-	105 x 28 mm	no	LED	731-DE1RT	p/pc	39,95
7 New Lucas-Style, red glass	ECE	110 x 30 mm	yes	LED	731LD01RT	p/pc	49,95
8 Clubman LED	-	70 x 45 mm	no	LED	731CL01SW	p/pc	129,95
9 Classic Lucas-Style	ECE	100 x 45 mm	yes	bulb	731CL02PO	p/pc	109,95
10 reflector		With adjustable bracket			460RS01	p/pc	14,95
10 reflector		Inflexible, with bracket for riveting			460RS02	p/pc	9,95
10 reflector		separate party			461-R01	p/pc	3,95
11 Universal license plate light		47 mm			732ULD3	p/pc	19,95



_ 12 FLASHER RELAY

Complete with adapter cable for exchange of standard flat tongue (6.2mm) to compact connector (2.8mm).



_ 13 BLINKERSTANGEN

Blinkerstangen aus Aluminium, Gewinde M8 oder M10 x 1.25.



_ 14 INDICATORS RETAINING TABS

Bracket for universal mounting of accessory flashers with M8 and M10 threaded shaft.

indicators accessories	colour	dimensions	item no	count	EUR
flasher relay					
12 flasher relay,		LED-100W, with adapter harness	720BD01	p/pc	29,95
indicator rods, aluminum					
13 indicator rods, (s. fig.)	black	M8, 40 mm	720LS40-M8	pair	34,95
13 indicator rods, (without fig.)	black	M8, 70 mm	720LS70-M8	pair	34,95
13 indicator rods, (without fig.)	black	M10x1.25, 40 mm	720LS40	pair	34,95
13 indicator rods, (without fig.)	black	M10x1.25, 70 mm	720LS70	pair	34,95
13 indicator rods, (without fig.)	silver	toothed, 60 mm	720CS01	pair	34,95
indicators retaining tabs					
14 bracket, universal, (s. fig.)	silver	with bore 10 mm	143BE1	pair	12,95
14 bracket, universal, (without fig.)	black	with bore	720BH2SW	pair	16,95
14 bracket for Yamaha indicators, (without fig.)	black	black	720BHY129	pair	14,95

_ INSTRUMENTS

MODEL SPECIFIC MOTOGADGET KITS

For motorcycles with a CAN-Bus system tacho conversions with new, smaller instruments become a technical challenge, since the CAN-Bus system requests the mounted speedometer board as a participant in its data exchange.

LSL now manufactures complete kits, containing the speedometer instrument, the arithmetic unit, the model-specific holders and an operator panel with switch and indicator light. So every talented mechanic is able to replace

the display instrument of the new Triumph Twins to a solution of Motogadget.

model	year	item no	EUR
instruments kit			
Triumph Bonneville, Thruxton, Scrambler	11-15	722T051TISW	659,00
Kawasaki W 800	all	722K137TISW	559,00
Motogadget Tiny			
speedometer, 200 km/h	black	723MSTISPSW	239,00
model specific bracket for Triumph Twins			
Bonneville, Thruxton, Scrambler	black	-15 723TT24SW	34,95



722T051TISW

INSTRUMENT BRACKET

Due to slider tube mounting clips the motoscope Tiny and Classic can also be mounted to the fork. The bracket consists of an instrument holding plate and a universal mount clamp for the slider tube.

instrument bracket			
fork clamp 39 mm	black	723M039SW	39,95
fork clamp 41 mm	black	723M041SW	39,95
fork clamp 43 mm	black	723M043SW	39,95
holding plate Tiny	black	723MST01SW	29,95
holding plate Velona	black	725-HV1SW	29,95



item	colour	item no	EUR
------	--------	---------	-----

Daytona Velona single instruments			
speedometer	200 km/h	black	725DV01SW 99,95
rev counter	8000 U/min	black	726DV01SW 99,95

Analog tachometer, 0 - 200 km/h, Mounting Ø: 60 mm, Weight: 170 g

item	year	item no	EUR
------	------	---------	-----

model specific Velona kits			
Kawasaki W 650	all	722K086VESW	329,00
Kawasaki W 800	all	722K137VESW	419,00
Triumph Modern Classic	-10	722T024VESW	419,00

item	item no	EUR
------	---------	-----

speedometer sensor		
universal Hall sensor speedometer M8x30	723-TS1	37,00
speedometer sensor Ø10/M5, (div. Honda/Triumph o.CAN-Bus)	725-TS2	34,95
speedometer sensor M11, fork (div. Kawasaki)	725-TS5	34,95
speedometer sensor M12, fork (div. Kawasaki)	725-TS3	34,95
Tachosensor M12, square (div. Yamaha)	725-TS4	34,95

Speedometer sensor, screwing directly into the speedometer drive such as a speedometer cable

indicator lights			
LED unit indicator light (without fig.)	black	725LED01SW	59,95

INSTRUMENTS COVER

Polished aluminum covers are available for Bonneville and Thruxton speedometer and tachometer instruments. Also available for models with electronic speedo!



model	item no	EUR
-------	---------	-----

speedometer cable drive		
Bonneville -10	speedometer only	727T024 79,95
Thruxton -10	speedo- & tachometer	727T031 149,95

electrical speedometer		
E.g. Bonneville -15	speedometer only	727T056 79,95
E.g. Thruxton -15	speedo- & tachometer	727T050 149,95

SINGLE INSTRUMENTS **VELONA**

The Velona instruments combine attractive design with high functionality for an affordable price. The stainless steel case is available in matt black coated or polished. The indirectly illuminated pointer is led by a stepping motor precisely on the black dial with white illuminated digits. The display is illuminated in blue.

Modelspecific Velona-Kits come with new harness, LED panel and all necessary mounting equipment.

SPEEDOMETER **SENSOR**



Coloured control lamp unit for displaying neutral, high beam, turn signals and warning light. (see table on the left)

INSTRUMENT **HOLDER**

CNC-machined speedometer bracket with LED monitoring panel. Suitable for the conversion to single instrument on the new EFI models. Finish equipped with original plug.



model	year	item no	EUR
-------	------	---------	-----

tachometer bracket with LED panel			
Triumph Scrambler	11-15	724T051	149,95

_ ALWAYS THE BEST INFORMATION



ALWAYS THE BEST INFORMATION

On the LSL website you find always the most actual information about LSL products and activities.

www.LSL.eu



Certificate of global GS1 System



The quality management system of LSL is certified since 1997 according to DIN EN ISO 9001

aluminum fender	112	handlebar extensions	51
axle balls	107	handlebar strut	31
banjo bolts	71	head net	47
bar end weights	50	headlight	121
bracket kit ignition relocation / horn	125	- headlight grid	121
brake fluid reservoir	68	- urban headlight kits	124
brake lines	70	- headlight brackets & clamps	122
brake pump protection	117	ignition relocation bracket kit	125
chain guard	116	indicators / accessories	126
clip - on		injection cover	117
- sport match	42	instruments	128
- adjustable handlebar clamps	42	instruments cover (Triumph)	129
- touren match	44	insulating wrap	117
Clubman® leather case	114	knurled head screws	114
Crash Pad®	101	lever for brake and clutch	59
crash protection / protectors		- scooter-lever	67
- Crash Pad®	101	lever guards	52
- axle balls	107	lifter	109
drilling template	47	mirror	53
engine protection	117	mirror adapter	56
flasher relay / indicators retaining tabs	127	mirror extension	57
food peg	88	number plate holder	118
food peg linking, standard & adjustable	89	oil filler cap	115
fork gaiters	117	rear lights	127
Top Yokes kits	15	rearsets	
GFK fender	111	- 2Slide	79
grips	49	- standard	82
handlebar		seats	114
- 22,2 mm handlebar	26	shift levers	87
- 25,4 mm handlebar (1 inch)	34	sprocket cover	116
- 28,6 mm handlebar / 32,0 mm	20	steering damper	97
handlebar clamps		superbike conversion kits	73
- clamps for 22,2 mm	32		
- clamps for 25,4 mm (1 inch)	39		
- clamps for für 28,6 mm	23		

COMPANY DETAILS

Editor

LSL Motorradtechnik GmbH, D-47809 Krefeld

Composition & print

Das Druckhaus Beineke Dickmanns GmbH,
Korschenbroich

Publication and reprint subject to written
permission of editor.

